

## Quickie<sup>®</sup> NITRUM<sup>®</sup>

**Supplier:** This manual must be given to the rider of this wheelchair.

**Rider:** Before using this wheelchair read this entire manual and save for future reference.

Owner's Manual

## Quickie<sup>®</sup> NITRUM<sup>®</sup>

**Distribuidor:** Este manual debe ser entregado al pasajero de esta silla de ruedas.

**Pasajero:** Antes de usar esta silla de ruedas, lea este manual en su totalidad y guárdelo para futura referencia.

Manual de Instrucciones

Cada una de las sillas se envía con un manual de instrucciones en inglés. El manual en español y francés está disponible en formato PDF en nuestra página en Internet: [www.SunriseMedical.com](http://www.SunriseMedical.com). Ingrese a la página del producto específico para descargar el manual, o comuníquese con el proveedor autorizado de Sunrise Medical.

## Quickie<sup>®</sup> NITRUM<sup>®</sup>

**Au Fournisseur:** Ce manuel doit être remis à l'utilisateur de ce fauteuil roulant.

**À l'Usager:** Veuillez lire tout le manuel et le conserver pour référence ultérieure.

Manuel d'Instructions

Chaque fauteuil est livré avec un manuel d'instructions en anglais. Les versions en espagnol et en français sont à votre disposition en format PDF sur le site : [www.SunriseMedical.com](http://www.SunriseMedical.com). Veuillez vous rendre à la page de votre produit pour télécharger le manuel dans la langue souhaitée, ou contactez un fournisseur agréé Sunrise Medical.

P/N 249817 Rev. D

Instructions for Use

**Quickie<sup>®</sup> Nitrum<sup>®</sup>**

**SUNRISE MEDICAL LISTENS**

Thank you for choosing a Quickie wheelchair. We want to hear your questions or comments about this manual, the safety and reliability of your chair, and the service you receive from your Sunrise Medical authorized dealer. Please feel free to write or call us at the address and telephone number below:

SUNRISE MEDICAL (US) LLC  
Customer Service Department  
12002 Volunteer Blvd.  
Mount Juliet, TN 37122, USA  
(800) 333-4000



[www.SunriseMedical.com/register](http://www.SunriseMedical.com/register)

Be sure to register your wheelchair and let us know if you change your address. This will allow us to keep you up to date with information about safety, new products, and options to increase your use and enjoyment of the wheelchair.

You can also register your product at:  
[www.SunriseMedical.com/register](http://www.SunriseMedical.com/register)

**FOR ANSWERS TO YOUR QUESTIONS**

Your authorized dealer knows your wheelchair best and can answer most of your questions about chair safety, use, and maintenance.

For future reference, please fill in the following:

Dealer: \_\_\_\_\_

Address: \_\_\_\_\_

Telephone: \_\_\_\_\_

Serial #: \_\_\_\_\_ Date/Purchased: \_\_\_\_\_

**ADDITIONAL INFORMATION YOU SHOULD KNOW**

No component of this chair was made with Natural Rubber Latex.



**DISPOSAL AND RECYCLING INFORMATION**

When this product reaches the end of its life, please take it to an approved collection or recycling point designated by your local or state government. This product is manufactured using a variety of materials.

Your product should not be disposed of as ordinary household waste. You should dispose of your product properly, according to local laws and regulations. Most materials that are used in the construction of this product are fully recyclable. The separate collection and recycling of your product at the time of disposal will help conserve natural resources and ensure that it is disposed in a manner that protects the environment.

Ensure you are the legal owner of the product prior to arranging for the product disposal in accordance with the above recommendations.

## II. TABLE OF CONTENTS

I.	INTRODUCTION.....	2	I.	Push Handles (Option).....	13
II.	TABLE OF CONTENTS.....	3	J.	Quick-Release Axles.....	13
III.	YOUR UNIT AND ITS PARTS.....	4	K.	Rear Wheels.....	13
IV.	NOTICE — READ BEFORE USE.....	4	L.	Rear Wheel Locks.....	13
	A. Choose the Right Chair and Safety Options.....	4	M.	Modified Seat Systems.....	13
	B. Review This Manual Often.....	4	N.	Seat and Back Upholstery.....	14
	C. Warnings.....	4	O.	Backrest Tension Adjustable.....	14
V.	GENERAL WARNINGS.....	5	P.	Freestyle Back (Option).....	14
	A. Weight Limit.....	5	Q.	Folding Lock Down Adjustable Backrest.....	14
	B. Intended Use.....	5	R.	Seat Back.....	14
	C. Attendants and Caregivers.....	5	S.	Backrest - Towel Bar.....	14
	D. Accessories.....	5	VIII.	USE AND MAINTENANCE.....	15
	E. Know Your Chair.....	5	A.	Introduction.....	15
	F. Reduce the Risk of an Accident.....	5	B.	Critical Safety Checks.....	15
	G. Safety Checklist.....	6	C.	Cleaning.....	15
	H. Changes and Adjustments.....	6	D.	Safety Checklist.....	15
	I. Environmental Conditions.....	6	E.	Troubleshooting Chart.....	15
	J. Terrain.....	6	F.	To Mount and Remove Rear Wheels.....	16
	K. Street Use.....	6	G.	Wheel Locks.....	16
	L. Motor Vehicle Safety.....	6	H.	Anti-tips.....	16
	M. When You Need Help.....	7	I.	Single Post Height Adjustable Armrests (Option).....	17
	N. Choking Hazard.....	7	J.	Padded Swing-away Armrests (Option).....	17
	O. Pinch Point.....	7	K.	Flip-up Footplate (Option).....	17
	P. Sharp Edges.....	7	L.	Freestyle Back (Option).....	17
	Q. Electrical Shock.....	7	M.	Back Angle Performance.....	18
	R. LED and Battery Pack.....	7	N.	Tension Adjustable Upholstery.....	18
VI.	SAFETY WARNINGS: FALLS AND TIP-OVERS.....	8	O.	Seat Sling Adjustment.....	19
	A. Center of Balance.....	8	P.	Tension Adjustable Seat Sling.....	19
	B. Dressing or Changing Clothes.....	8	Q.	Cushion Installation.....	19
	C. Obstacles.....	8	R.	Storage Tips.....	19
	D. Front Caster Lift.....	8	S.	LED and Battery Pack.....	20
	E. Reaching or Leaning.....	8	T.	Check Out.....	20
	F. Moving Backward.....	8	IX.	DEALER SERVICE AND ADJUSTMENT.....	21
	G. Escalators.....	9	A.	Dealer Service Introduction.....	21
	H. Ramps, Slopes, and Sidehills.....	9	B.	Critical Maintenance Tips.....	21
	I. Transfers.....	10	C.	Cleaning.....	21
	J. Curbs and Single Steps.....	10	D.	Rear Wheel Axle Nut Adjustment.....	21
	K. Climbing a Curb or Single Step.....	11	E.	Anti-tip Receiver.....	21
	L. Descending a Curb or Single Step.....	11	F.	Wheel Locks.....	22
	M. Stairs.....	11	G.	Armrest Receiver Attachment.....	22
	N. Climbing Stairs.....	11	H.	Padded Swing Away Armrests (Option).....	23
	O. Descending Stairs.....	11	I.	Casters.....	23
VII.	WARNINGS: COMPONENTS AND OPTIONS.....	12	J.	Caster Fork Adjustment.....	24
	A. Anti-tip Tubes.....	12	K.	Footrest Height Adjustment.....	26
	B. Armrests.....	12	L.	Adjusting Rear Seat Height.....	26
	C. Cushion and Sling Seats.....	12	M.	Backrest.....	27
	D. Fasteners.....	12	N.	Freestyle Back Maintenance and Adjustment.....	27
	E. Footrests.....	12	O.	4-LINK Rear Suspension.....	28
	F. Pneumatic Tires.....	12	P.	Rear Axle.....	29
	G. Offset Seating (Option).....	13	Q.	Rear Wheel Spacing.....	31
	H. Positioning Belts (Option).....	13	R.	Check Out.....	31
			X.	SUNRISE LIMITED WARRANTY.....	31

**NITRUM**



- |                       |                   |
|-----------------------|-------------------|
| 1. Back Upholstery    | 7. Caster Housing |
| 2. Tire               | 8. Camber Tube    |
| 3. Handrim            | 9. Caster Fork    |
| 4. Quick Release Axle | 10. Footrest      |
| 5. Spokes             | 11. Wheel Lock    |
| 6. Caster Wheel       | 12. Seat Sling    |

NOTE: All features may not be available with some chair setups or in conjunction with another chair feature. Please consult your Sunrise Medical authorized dealer for information.

Open Fixed Front Frame



IV. NOTICE — READ BEFORE USE

**A. CHOOSE THE RIGHT CHAIR AND SAFETY OPTIONS**

Sunrise provides a choice of many wheelchair styles to meet your needs. This product is intended for single person use only. Final selection of the type of wheelchair, options, and adjustments rests solely with you and your health care provider. Choosing the best chair for your unique mobility needs will depend on such things as:

1. Your disability, grasping strength, balance and coordination.
2. The types of hazards you must overcome in daily use (where you live and work, and other places you are likely to use your chair).
3. The need for options that will improve your positioning, safety, and comfort (such as anti-tip tubes, positioning belts, or special seating systems).

**B. REVIEW THIS MANUAL OFTEN**

Before using this chair you, and each person who may assist you, should read this entire manual and ensure to follow all instructions. Review the warnings often, until they are second nature to you.

**C. WARNINGS** 

The word "WARNING" refers to a hazard or unsafe practice that may cause severe injury or death to you or to other persons. The "Warnings" are in three main sections, as follows:

1. **V - GENERAL WARNINGS**  
Here you will find a safety checklist and a summary of risks you need to be aware of before you ride this chair.
2. **VI - SAFETY WARNINGS: FALLS AND TIP-OVERS**  
Here you will learn about practices for the safe use of your chair, and how to avoid a fall or tip-over while you perform daily activities in your chair.
3. **VII - WARNINGS — COMPONENTS AND OPTIONS**  
Here you will learn about the components of your chair and options you can select for safety. Consult your Sunrise Medical authorized dealer and your health care provider to help you choose the best set-up and options for safe use.

NOTE: Where they apply, you will also find "Warnings" in other sections of this manual. Heed all warnings in these sections. If you fail to do so a fall, tip-over, or loss of control may occur and cause severe injury to the rider or others.



## V. GENERAL WARNINGS

### A. WEIGHT LIMIT

#### WARNING

NEVER exceed the weight limit specified by Sunrise Medical. The weight capacity provided by your manufacturer is for the combined weight of a rider and items carried using on-board storage. If you do exceed the weight limit, damage to your chair, a fall, tip-over, or loss of control may occur and cause severe injury to the rider or others.

#### Weight Capacity

Quickie NITRUM (Open Fixed Front) - 275 lbs (125 kg)

Quickie NITRUM (Hybrid Frame) - 300 lbs (136 kg)

### B. INTENDED USE

The Quickie NITRUM wheelchair's intended use is to provide mobility to persons limited to a sitting position.

#### WARNING

DO NOT use this device for purposes other than what is intended by the manufacturer.

1. The wheelchair is not designed for weight training and is unsafe for use as a seat while weight training. Weight training from the wheelchair substantially changes the stability of the chair and may cause tipping.
2. DO NOT stand on the frame of the wheelchair.
3. NEVER allow someone to stand on your chair or use it as a step ladder.
4. This chair is designed for a single rider only.
5. Unauthorized modifications and use of parts or accessories not supplied or approved by Sunrise Medical may change the chair structure. This will void the warranty and may cause a safety hazard. If the warning is ignored, damage to your chair, and the potential for severe injury of the person using the chair for unintended purposes can occur.

### C. ATTENDANTS AND CAREGIVERS

#### WARNING

Before you assist a rider, ensure you read all warnings contained in this manual and follow all instructions that apply. Be aware that after consulting a health care provider, you will need to learn safe and proven body mechanics to use and create assistive methods best suited to your abilities.

### D. ACCESSORIES

#### WARNING

Unauthorized modifications or use of parts or accessories not supplied or approved by Sunrise Medical may change the chair structure. This will void the warranty and may cause a safety hazard.

Some problems that may occur, but are not limited to:

1. Incorrect wheels and/or tires that put the rider at risk of a fall or tip-over.
2. Adding a component to the frame, changing the structural integrity of the chair.
3. Any modification or disassembly can potentially create an unsafe situation where rider and/or attendant are put at risk.

### E. KNOW YOUR CHAIR

#### WARNING

Every wheelchair is different. Take the time to learn the feel of this chair before you begin riding. Start slowly, with easy, smooth strokes. If you are used to a different chair, you may use too much force and tip over. If you use too much force, damage to your chair, a fall, tip-over, or loss of control may occur and cause severe injury to the rider or others.

### F. REDUCE THE RISK OF AN ACCIDENT

#### WARNING

1. BEFORE you begin riding, you should be trained in the safe use of this chair by your health care provider.
2. Practice bending, reaching, and transfers until you know the limit of your ability. Have someone help you until you know what can cause a fall or tip-over and how to avoid doing so.
3. Be aware that you must develop your own methods for safe use best suited to your level of function and ability.
4. NEVER try a new maneuver on your own. Ask the advice of your health care provider to lower the risk of a fall or tip over.
5. Get to know the areas where you plan to use your chair. Look for hazards and learn how to avoid them.

**G. SAFETY CHECKLIST**

**⚠ WARNING**

Before Each Use Of Your Chair:

1. Ensure the chair rolls easily and that all parts work smoothly. Check for noise, vibration, or a change in ease of use. (This may indicate low tire pressure, loose fasteners, or damage to your chair).
2. Immediately repair any problem. Your Sunrise Medical authorized dealer can help you find and correct the problem(s).
3. Ensure that both quick-release rear axles are locked. When locked, the axle button will “pop out” fully. If not locked, the wheel may come off and cause you to fall.
4. If your chair has anti-tip tubes, lock them in place.

**H. CHANGES AND ADJUSTMENTS**

**⚠ WARNING**

1. See your health care provider and have them adjust seating components any time a change or adjustment needs to be made.
2. Unauthorized modifications or use of parts not supplied or approved by Sunrise Medical may change the chair structure. This will void the warranty and may cause a safety hazard.

If you fail to heed these warnings, damage to your chair, a fall, tip-over or loss of control may occur and cause severe injury to the rider or others.

**I. ENVIRONMENTAL CONDITIONS**



**⚠ WARNING**

1. Use extra care if you must ride your chair on a wet or slick surface. If you are in doubt, ask for help.
2. Contact with water or excess moisture may cause your chair to rust or corrode. Avoid all extreme weather situations if possible.
  - a. Do not use your chair in a shower, pool, or other body of water. The chair tubing and parts are not water-tight and may rust or corrode from the inside.
  - b. Avoid excess moisture (for example, do not leave your chair in a damp bathroom while taking a shower).
  - c. Dry your chair as soon as you can if it gets wet, or if you use water to clean it.

If you fail to heed these warnings, damage to your chair, a fall, tip-over, or loss of control may occur and cause severe injury to the rider or others.

**J. TERRAIN**

**⚠ WARNING**

1. Based on ANSI/RESNA testing, Sunrise Medical recommends the use of a caster wheel with a minimum diameter of 5-in, if the wheelchair will be overcoming obstacles up to 1/2-in on a regular basis.
2. Your chair is designed for use on firm, even surfaces such as concrete, asphalt, indoor flooring, and carpets.
3. Do not operate your chair in sand, loose soil, or over rocky terrain.
4. If you use your chair on terrain that is rougher than described above there is a danger that screws and bolts will loosen prematurely, and that damage to wheels or axles could put the rider at risk of a fall, tip-over, or loss of control.

If you fail to heed these warnings, damage to your chair, a fall, tip-over, or loss of control may occur and cause severe injury to the rider or others.

**K. STREET USE**

**⚠ WARNING**

1. This product is not intended for street use.
2. Avoid streets whenever possible.
3. Obey and follow all legal pedestrian pathways, and laws that apply to pedestrians.
4. Be alert to the danger of motor vehicles in parking lots, or if you must cross a road.

If you fail to heed these warnings, damage to your chair, a fall, tip-over, or loss of control may occur and cause severe injury to the rider or others.

**L. MOTOR VEHICLE SAFETY** 1 2

If possible and feasible, the rider should transfer to the Original Equipment Manufacturer vehicle seat and use the OEM vehicle restraint.

Sunrise Medical does provide a WC-19 Wheelchair Tie-Down and Occupant Restraint System, otherwise called a Transit Option. To identify whether your wheelchair has been manufactured with the Transit Option installed, look for four points of securement. Two Front points, (A) and two rear points (B). These points are recognized by the securement point decal which can be found on or near the securement points. If your wheelchair is equipped with the Transit Option please review the Transit Securement supplement that was provided with the wheelchair for additional information and instructions. You can request a copy from your Sunrise Medical authorized dealer, or Sunrise Medical if you don't have it.



Look for this symbol on your wheelchair. It indicates wheelchair securement points which conform to ANSI/RESNA (1998) V.1 –Section 19 & ANSI/RESNA (2012) V.4 WC-19.

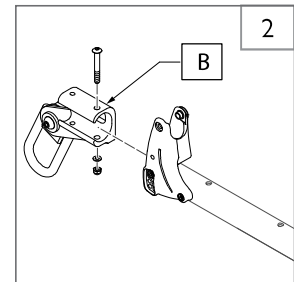
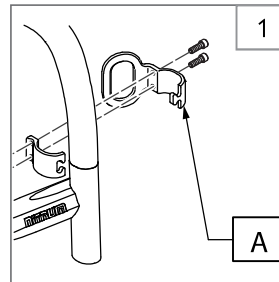

**⚠ WARNING**

If your chair is NOT equipped with the Transit Option:

1. NEVER let anyone sit in this chair while in a moving vehicle.
  - a. ALWAYS move the rider to an approved vehicle seat.
  - b. ALWAYS secure the rider with proper motor vehicle restraints.
2. In an accident or sudden stop the rider may be thrown from the chair. Wheelchair seat belts will not prevent this, and further injury may result from the belts or straps.
3. NEVER transport this chair in the front seat of a vehicle. It may shift and interfere with the driver.
4. ALWAYS secure this chair so that it cannot roll or shift.
5. Do not use any chair that has been involved in a motor vehicle accident. The frame and/or components may have been changed due to the accident. Such items could be, but are not limited to: bent, loosened, and/or broken components that were subjected to an impact.

If you fail to heed these warnings, damage to your chair, a fall, tip-over, or loss of control may occur and cause severe injury to the rider or others.

## V. GENERAL WARNINGS

### M. WHEN YOU NEED HELP

#### WARNING

For The Rider: Ensure that each person who helps you reads and follows all warnings and instructions that apply.

For Attendants:

1. Work with the rider's doctor, nurse, or therapist to learn safe methods best suited to your abilities and those of the rider.
2. Tell the rider what you plan to do, and explain what you expect the rider to do. This will put the rider at ease and reduce the risk of an accident.
3. Ensure the chair has push handles. They provide secure points for you to hold the rear of the chair to prevent a fall or tip-over. Check to ensure push handle grips will not rotate or slip off.
4. To prevent injury to your back, use good posture and proper body mechanics. When you lift or support the rider or tilt the chair, bend your knees slightly and keep your back as upright and straight as you can.
5. Remind the rider to lean back when you tilt the chair backward.
6. When you descend a curb or single step, slowly lower the chair in one easy movement. Do not let the chair drop the last few inches to the ground. This may damage the chair or injure the rider.
7. To avoid tripping, unlock and rotate anti-tip tubes up, out of the way.
8. Whenever you aren't attending the wheelchair, ALWAYS use the wheel-lock to secure the rear wheels, and lock the anti-tip tubes in place.

If you fail to ask for help when in doubt, you run a high risk of a fall, tip-over, or loss of control that may occur and cause severe injury to the rider or others.

### N. CHOKING HAZARD

#### WARNING

Your chair consists of many small parts that could present a choking or swallowing hazard to young children. Take care to keep loose parts out of reach when doing any work on the chair. Seek immediate help if a loose part is swallowed by a child.

### O. PINCH POINT

#### WARNING

Your wheelchair has many moving parts that can create pinch points and possible finger traps. Be aware when making any adjustments, when folding and unfolding, when moving, and any other situation that could cause a pinch point situation.

### P. SHARP EDGES

#### WARNING

This wheelchair contains parts and hardware of many shapes and sizes. When using or working around the wheelchair, take caution to avoid any corners or edges that may cause a scrape or a cut.

### Q. ELECTRICAL SHOCK

#### WARNING

When using this wheelchair, please take all precautions to avoid situations that can possibly cause an electric shock to the patient, caregiver, or wheelchair itself. Situations would include: while maintaining the optional LED and battery pack assembly and wiring; using electrical appliances near water while using the wheelchair; working on electrical equipment while in the chair, during severe weather conditions.

### R. LED AND BATTERY PACK

#### WARNING

Use caution if the LED lights or battery pack need to be serviced or repaired. If in doubt, disconnect the LED lights from the battery pack. Please contact your Sunrise Medical authorized dealer or manufacturer with any questions you may have.

1. Before you use the LED light for the first time, please ensure the battery is fully charged.
2. Battery for LED Lights: Lithium Ion battery (hazardous product).
3. Electrical and electronic equipment need to be disposed of separately to general household waste at specific state provided locations. The correct disposal and separate collection of used appliances serves to prevent potential damage to health and the environment. It is a requirement for the re-utilization and recycling of used electrical and electronic equipment.
4. Detailed information on the disposal of your used equipment can be obtained from your local authority, your waste disposal or service, the specialist dealer from which you purchased the product, your sales contact.



**A. CENTER OF BALANCE****⚠ WARNING**

The point where this chair will tip forward, back, or to the side depends on its center of balance and stability. How your chair is set up, the options you select and the changes you make may affect the risk of a fall or tip-over.

1. The Most Important Adjustment Is:  
The position of the rear wheels. The more you move the rear wheels forward, the more likely your chair will tip over backward.
1. The Center Of Balance Is Also Affected By:
  - a. A change in the set-up of your chair, including:
    - The distance between the rear wheels.
    - The amount of rear wheel camber.
    - The seat height and seat angle.
    - Backrest angle.
  - b. A change in your body position, posture, or weight distribution.
  - c. Riding your chair on a ramp or slope.
  - d. A backpack or other options and the amount of added weight.
2. To Reduce The Risk Of An Accident:
  - a. Consult your doctor, nurse, or therapist to find out what axle and caster position is best for you.
  - b. Consult your Sunrise Medical authorized dealer BEFORE you modify or adjust this device. Be aware that you may need to make other changes to correct the center of balance.
  - c. Have someone help you until you know the balance points of your chair and how to avoid a tip-over.
  - d. Use anti-tip tubes.

If you fail to heed these warnings, you are at a high risk of a fall, tipover, or loss of control that could cause severe injury to the rider or others.

**B. DRESSING OR CHANGING CLOTHES****⚠ WARNING**

Your weight may shift if you dress or change clothes while seated in this chair.

To reduce the risk of a fall or tip-over:

1. Rotate the front casters until they are as far forward as possible. This makes the chair more stable.
2. Lock anti-tip tubes in place. (If your chair does not have anti-tip tubes, back it up against a wall and lock both rear wheels).

If you fail to heed these warnings, you are at a high risk of a fall, tipover, or loss of control that could cause severe injury to the rider or others.

**C. OBSTACLES****⚠ WARNING**

Riding over curbs or obstacles can cause tipping and serious bodily harm. If you have any doubt that you can safely cross any curb or obstacle, ALWAYS ASK FOR HELP. Be aware of your riding skills and personal limitations. Develop new skills only with the help of a companion.

To avoid the risk of traversing obstacles:

1. Keep a lookout for danger – scan the area well ahead of your chair as you ride.
2. Ensure the floor areas where you live and work are level and free of obstructions.
3. Remove or cover threshold strips between rooms.
4. Install a ramp at entry or exit doors. Ensure there is not a drop off at the bottom of the ramp.
5. To Help Correct Your Center Of Balance:
  - a. Lean your upper body FORWARD slightly as you go UP over an obstacle.
  - b. Press your upper body BACKWARD as you go DOWN from a higher to a lower level.
6. If your chair has anti-tip tubes, do not go over an obstacle without help.
7. Keep both of your hands on the handrims as you go over an obstacle.

8. Never push or pull on an object (such as furniture or a doorjamb) to propel your chair.

If you fail to heed these warnings, you are at a high risk of damage to your chair, a fall, tip-over, or loss of control that may occur and cause severe injury to the rider or others.

**D. FRONT CASTER LIFT****⚠ WARNING**

Front caster lift can occur when the front wheels, ordinarily in contact with the ground, are either intentionally or unintentionally caused to lift from the ground while the rear wheels remain in contact. Pitch control (partial or full) should NEVER be attempted without consulting your health care provider and ensuring that anti-tips are attached.

**E. REACHING OR LEANING****⚠ WARNING**

If you reach or lean it will affect the center of balance of your chair. This may cause you to fall or tip over. When in doubt, ask for help or use a device to extend your reach.

1. NEVER reach or lean if you must shift your weight sideways or rise up off the seat.
2. NEVER reach or lean if you must move forward in your seat to do so. Always keep your buttocks in contact with the backrest.
3. NEVER reach with both hands (you may not be able to catch yourself to prevent a fall if the chair tips).
4. NEVER reach or lean to the rear unless your chair has anti-tip tubes locked in place.
5. DO NOT reach or lean over the top of the seat back. This may damage one or both backrest tubes and cause you to fall.
6. If You Must Reach Or Lean:
  - a. Do not lock the rear wheels. This creates a tip point and makes a fall or tip-over more likely.
  - b. Do not put pressure on the footrests.
  - c. Move your chair as close as you can to the object you wish to reach.
  - d. Do not try to pick up an object from the floor by reaching down between your knees. You are less likely to tip if you reach to the side of your chair.
  - e. Rotate the front casters until they are as far forward as possible. This makes the chair more stable.
  - f. Firmly grasp a rear wheel or an armrest with one hand. This will help to prevent a fall if the chair tips.

If you fail to heed these warnings damage to your chair, a fall, tip-over, or loss of control may occur and cause severe injury to the rider or others.

**F. MOVING BACKWARD****⚠ WARNING**

Use extra care when you move your chair backward. Your chair is most stable when you propel yourself forward. You may lose control or tip over if one of the rear wheels hits an object and stops rolling.

1. Propel your chair slowly and smoothly.
2. If your chair has anti-tip tubes, ensure they are locked in place.
3. Stop often and check to ensure your path is clear.

If you fail to heed these warnings damage to your chair, a fall, tip-over, or loss of control may occur and cause severe injury to the rider or others.

## VI. SAFETY WARNINGS: FALLS AND TIP-OVERS

### G. ESCALATORS

#### WARNING

NEVER use this chair on an escalator, even with an attendant. If you do, a fall or tip-over is likely.

If you fail to heed these warnings damage to your chair, a fall, tip-over or loss of control may occur and cause severe injury to the rider or others.

### H. RAMPS, SLOPES & SIDEHILLS 3 4 5 6

#### WARNING

Whenever possible, avoid riding on a slope, which includes a ramp or sidehill. This will change the center of balance of your chair. Your chair is less stable and more difficult to maneuver when it is at an angle. When moving up a hill, anti-tip tubes may not prevent a fall or tip-over.

1. DO NOT use your chair on a slope steeper than 6°. (A 6° slope means: one foot in elevation for every ten feet of slope length.)
2. ALWAYS go as straight up and as straight down as you can. (Do not “cut the corner” on a slope or ramp.)
3. DO NOT turn or change direction on a slope.
4. When you have to use a ramp, always stay in the CENTER of the ramp. Ensure ramp is wide enough that you have no risk of going off the edge.
5. DO NOT stop on a steep slope. If you stop, you may lose control of your chair.
6. NEVER use rear wheel locks to try to slow or stop your chair. This is likely to cause your chair to veer out of control.
7. ALWAYS be aware of:
  - a. Wet or slippery surfaces.
  - b. A change in grade on a slope (or a lip, bump, or depression). These may cause a fall or tip-over.
8. To Reduce The Risk Of A Fall Or Tip-Over:
  - a. Lean or press your body UPHILL. This will help adjust for the change in the center of balance caused by the slope or sidehill.
  - b. Keep pressure on the handrims to control your speed on a down slope. If you go too fast you may lose control.
  - c. ASK FOR HELP any time you are in doubt.
9. Ramps At Home and Work– For your safety, ramps at home and work must meet all legal requirements for your area:
  - a. AVOID A DROP-OFF  
Ensure there is a section at the top or bottom to smooth out the transition.
  - b. ALWAYS stay in the center of the ramp and control your speed.

If you fail to heed these warnings damage to your chair, a fall, tip-over, or loss of control may occur and can possibly cause severe injury to the rider or others.



- IF you need to go down a hill:
- a. The Downslope should be less than 6°
  - b. GO SLOW
  - c. ALWAYS Go Straight down
  - d. ALWAYS Control your speed
  - e. NEVER turn on a hill



- IF you need to go up a hill:
- a. The Upslope should be less than 6°
  - b. ALWAYS Go Straight up
  - c. NEVER Stop on the upslope
  - d. NEVER turn on a hill
  - e. ALWAYS lean forward

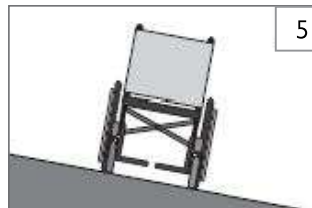

- IF you need to traverse a Sidehill:
- a. Sidehill must be less than 6° or you are risking a tip over
  - b. DON'T STOP
  - c. DO NOT make any Turns on the sidehill

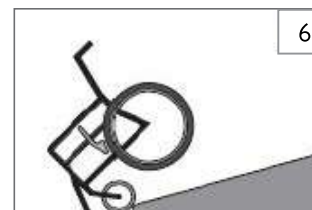

- IF you need to traverse a Ramp:
- a. Go Slowly
  - b. Watch out for Drop-offs
  - c. ALWAYS Go Straight down
  - d. Stay centered on the Ramp



## VI. SAFETY WARNINGS: FALLS AND TIP-OVERS

### I. TRANSFERS 7 8

#### WARNING

It is dangerous to transfer on your own. It requires good balance and agility. Be aware that there is a point during every transfer when the wheelchair seat is not below you.

To avoid a fall:

1. Work with your health care provider to learn safe methods for transfers.
  - a. Learn how to position your body and how to support yourself during a transfer.
  - b. Have someone help you until you learn safe transfer methods.
2. Lock the rear wheels before you transfer.
3. Be aware that the chair can still slide and/or tip. The wheel lock keeps the rear wheels from rolling while you are performing the transfer.
4. Ensure that the pneumatic tires are properly inflated. Low tire pressure may allow the rear wheel locks to slip. (see table in Section VII: F "Pneumatic Tires")
5. Move your chair as close as you can to the seat you are transferring to. If possible, use a transfer board.
6. Rotate the front casters until they are as far forward as possible.
7. If you can, remove the footrests, or swing them out of the way.
  - a. Ensure your feet do not catch in the space between the footrests.
  - b. Avoid putting weight on the footrests as this may cause the chair to tip.
8. Ensure armrests are removed, or out of the way and do not interfere with the transfer.
9. Transfer as far back onto the seat surface as you can. This will reduce the risk that the chair will tip or move away from you.

If you fail to heed these warnings damage to your chair, a fall, tip-over, or loss of control may occur and can possibly cause severe injury to the rider or others.

Optimum Transfer position



#### Before transferring:

1. Flip-back, or remove the armrests out of the way.
2. Swing, or remove the footrests out of the way.
3. Ensure the wheel lock is set.

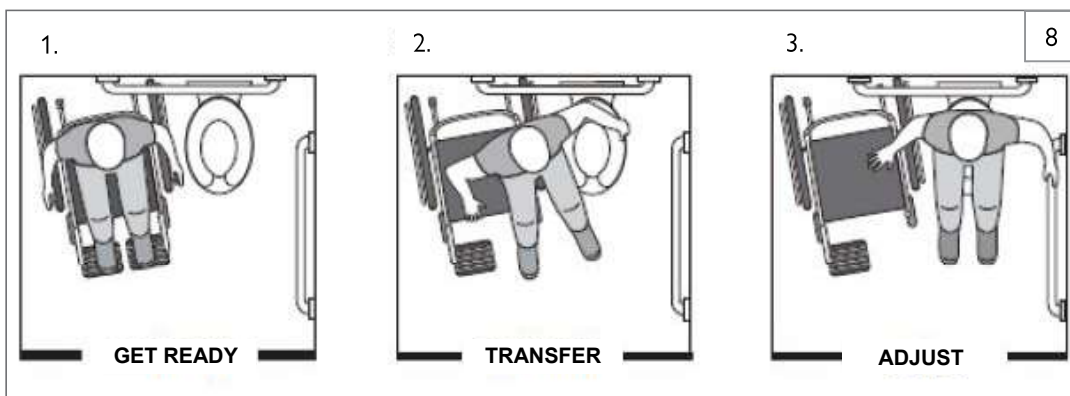

### J. CURBS & SINGLE STEPS 9

#### WARNING

Before riding over curbs, and negotiating even a single step, ALWAYS ask for assistance first. Curbs and steps can cause tipping and serious bodily harm. When in doubt as to your ability to avoid, or traverse any obstacle, always ask for help. Be aware of your riding skills and personal limitations. Develop new skills only with the help of a companion.

**For Attendant:** Each person who assists the rider with curbs and steps should read and follow all instructions and warnings pertaining to attendants and caregivers.

1. Do not try to climb a high curb or step (more than 4 inches high) UNLESS you have help. Doing so may cause your chair to exceed its balance point and tip over.
2. Go straight up and straight down a curb or step. If you climb or descend at an angle, a fall or tip-over is likely.
3. Be aware that the impact of dropping down from a curb or step can damage your chair or loosen fasteners.

If you fail to heed these warnings damage to your chair, a fall, tip-over, or loss of control may occur and can possibly cause severe injury to the rider or others.

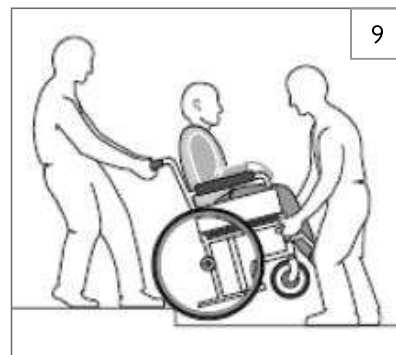



## VI. SAFETY WARNINGS: FALLS AND TIP-OVERS

### K. CLIMBING A CURB OR SINGLE STEP 9

#### WARNING

For Attendant: follow these steps to help the rider climb a curb or single step going BACKWARD:

1. Stay behind the chair.
2. Continue backward until the rear wheels contact the face of the curb or step. Lift and roll the rear wheels to the top of the curb.
3. Pull the chair backwards until the caster wheels have cleared the edge of the curb and return the chair to its rolling position.

If you fail to heed these warnings damage to your chair, a fall, tip-over, or loss of control may occur and cause severe injury to the rider or others.

### L. DESCENDING A CURB OR SINGLE STEP 9

#### WARNING

For Attendant: Follow these steps to help a rider descend a curb or single step going FORWARD:

1. Stay at the rear of the chair.
2. Several feet before you reach the edge of the curb or step, tip the chair slightly and pull it backward.
3. When the chair is at its balance point, carefully step forward until the rear wheels reach the edge of the curb or step. Then allow the rear wheels to slowly roll down onto the lower level.
4. Push the chair forward until you are standing on the lower level.
5. When the rear wheels are safely on the lower level, tilt the chair back to its balance point.

If you fail to heed these warnings damage to your chair, a fall, tip-over, or loss of control may occur and cause severe injury to the rider or others.

### M. STAIRS 10

#### WARNING

1. NEVER use this chair on stairs UNLESS you have someone to help you. Doing so is likely to cause a fall or tip-over.
2. Negotiating stairs with a wheelchair always requires at least two attendants for safety.
3. NEVER lift this chair by its armrests. They may come loose or break.
4. Lift this chair only by non-detachable parts of the main frame.

If you fail to heed these warnings damage to your chair, a fall, tip-over, or loss of control may occur and cause severe injury to the rider or others.

### N. CLIMBING STAIRS 10

#### WARNING

1. Use at least two attendants to move a chair and rider up stairs.
2. Move the chair and rider BACKWARD up the stairs.
3. The person at the rear is in control. He or she tilts the chair back to its balance point.
4. A second attendant at the front firmly grasps a non-detachable part of the front frame and lifts the chair up and over one stair at a time.
5. The attendants move to the next stair up. Repeat for each stair, until you reach the landing.

### O. DESCENDING STAIRS 10

#### WARNING

1. Use at least two attendants to move a chair and rider down stairs.
2. Move the chair and rider FORWARD down the stairs.
3. The person at the rear is in control. He or she tilts the chair to the balance point of the rear wheels and rolls it to the edge of the top step.
4. A second attendant stands on the third step from the top and grasps the chair frame. He or she lowers the chair one step at a time by letting the rear wheels roll over the stair edge.
5. The attendants move to the next stair down. Repeat for each stair, until you reach the landing.

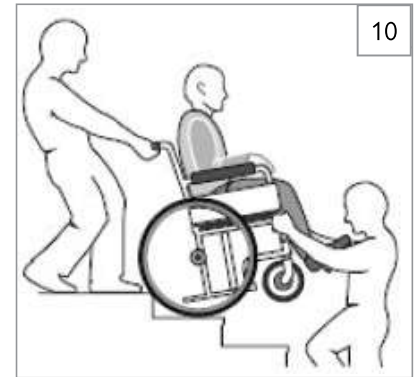

## VII. WARNINGS: COMPONENTS AND OPTIONS

### A. ANTI-TIP TUBES

#### WARNING

Anti-tip tubes can help keep your chair from tipping over backward in normal conditions.

1. Sunrise Medical recommends the use of anti-tip tubes.
2. When locked in place (in the “down” position) anti-tip tubes should be BETWEEN 1 1/2 to 2 inches off the ground.
  - a. If set higher than 2 inches, they may not prevent a tip-over.
  - b. If set lower than 1 1/2 inches, they may “hang up” on obstacles and cause a fall or tip over.
3. If you have to climb or descend a curb, or overcome an obstacle it may be necessary to have an attendant ensure the anti-tip tubes are rotated up, and out of the way, so that the chair and rider do not get stuck and/or become unstable.

If you fail to heed these warnings damage to your chair, a fall, tip-over, or loss of control may occur and cause severe injury to the rider or others.

### B. ARMRESTS

#### WARNING

Armrests detach and will not bear the weight of this chair.

1. NEVER lift this chair by its armrests. They may come loose or break.
2. Lift this chair only by non-detachable parts of the main frame.

If you fail to heed these warnings damage to your chair, a fall, tip-over, or loss of control may occur and cause severe injury to the rider or others.

### C. CUSHIONS AND SLING SEATS

#### WARNING

1. Quickie sling seats and standard foam cushions are not designed for the relief of pressure.
2. If you suffer from pressure sores or if you are at risk that they will occur, you may need a special seat system or a device to control your posture. Consult your doctor, nurse, or therapist to find out if you need such a device for your well-being.
3. Seat slings are not intended to be used as a direct seating surface. A cushion or other seating surface should be placed on the sling before use.

If you fail to heed these warnings damage to your chair, a fall, tip-over, or loss of control may occur and cause severe injury to the rider or others.

### D. FASTENERS

#### WARNING

Many of the screws, bolts, and nuts on this chair are special high-strength fasteners. Use of improper fasteners may cause your chair to fail.

1. ONLY use fasteners provided by a Sunrise Medical authorized dealer (or ones of the same type and strength, as indicated by the markings on the heads).
2. Over- or under-tightened fasteners may fail or cause damage to chair parts.
3. If bolts or screws become loose, tighten them as soon as you can.

If you fail to heed these warnings damage to your chair, a fall, tip-over, or loss of control may occur and cause severe injury to the rider or others.

### E. FOOTRESTS

#### WARNING

1. At the lowest point, footrests should be AT LEAST 2 inches off the ground. If set too LOW, they may “hang up” on obstacles you can expect to find in normal use. This may cause the chair to stop suddenly and tip forward.
2. To Avoid A Trip Or Fall When You Transfer:
  - a. Ensure your feet do not “hang up” or get caught in the space between the footrests.
  - b. Avoid putting weight on the footrests, as the chair may tip forward.
  - c. Footrests should be swung out of the way or removed whenever entering or exiting the wheelchair.
3. NEVER lift this chair by the footrests. Footrests detach and will not bear the weight of this chair. Lift this chair only by non-detachable parts of the main frame.
4. Never use the footrests of your chair to open doors, this may cause them to fail prematurely and create an unsafe situation.

If you fail to heed these warnings damage to your chair, a fall, tip-over, or loss of control may occur and cause severe injury to the rider or others.

### F. PNEUMATIC TIRES

#### WARNING

Proper inflation extends the life of your tires and makes your chair easier to use.

1. Do not use this chair if any of the tires are under- or over-inflated. Check weekly for proper inflation level, as listed on the tire sidewall.
2. Low pressure in a rear tire may cause the wheel lock on that side to slip and allow the wheel to turn when you do not expect it.
3. Low pressure in any of the tires may cause the chair to veer to one side and result in a loss of control.
4. Over-inflated tires may burst.

If you fail to heed these warnings damage to your chair, a fall, tip-over, or loss of control may occur and cause severe injury to the rider or others.

#### Recommended Tire Pressures

Tires	Nitrum	Recommended Pressure or Pressure Range	
		kPa	PSI
Pneumatic - 20"	x	448	65
Pneumatic - 22"	x	448	65
Pneumatic - 25"	x	448	65
Pneumatic - 26"	x	448	65
High Pressure Clincher (24")	x	758	110
High Pressure Clincher (26")	x	758	110
Knobby V-Track (24")	x	448	65
Schwalbe Marathon (22")	x	586-1000	85-145
Schwalbe Marathon (24")	x	586-1000	85-145
Schwalbe Marathon (25")	x	586-1000	85-145
Schwalbe Marathon (26")	x	586-1000	85-145
Schwalbe Speed Run (24")	x	586-1000	85-145
Schwalbe Speed Run (26")	x	586-1000	85-145

## VII. WARNINGS: COMPONENTS AND OPTIONS

### G. OFFSET SEATING (Option)

#### WARNING

1. A fore/aft change in the backrest position will affect the center of balance of your chair.
2. Only use this option when installing a forward offset mounted seating solution, not using the standard back sling.
3. Each time you adjust or modify the backrest plane location, the change may make it easier to tip backwards. Use anti-tips until you adapt to the change, and are sure you are not at risk to tip over.

If you fail to heed these warnings damage to your chair, a fall, tip-over, or loss of control may occur and cause severe injury to the rider or others.

### H. POSITIONING BELTS (Option)

#### WARNING

The positioning belt is predominately used to support your posture. It can also be used to limit slipping and/or sliding that you might experience when the chair is in motion. The positioning belt is not a transit rated safety belt and should not be used in the place of a seat belt while being transported in a motor vehicle. Improper use of positioning belts may cause severe injury or death. If you use a positioning belt, ensure you follow the recommendations in this section:

1. Ensure the rider does not slide down in the wheelchair seat. If this occurs, the rider may suffer chest compression or suffocate due to pressure from the belts.
2. The belts must be snug but must not be so tight that they interfere with breathing. You should be able to slide your open hand, flat, between the belt and the rider.
3. A pelvic wedge or a similar device can help keep the rider from sliding down in the seat. Consult with the rider's doctor, nurse, or therapist to find out if the rider needs such a device.
4. Use positioning belts only with a rider who can cooperate. Ensure the rider can easily remove the belts in an emergency.
5. NEVER use positioning belts
  - a. As a patient restraint. A restraint requires a doctor's order.
  - b. On a rider who is comatose or agitated.
  - c. As a motor vehicle restraint. In an accident or sudden stop the rider may be thrown from the chair. Wheelchair positioning belts will not prevent this, and further injury may result from the belts or straps.

If you fail to heed these warnings, damage to your chair, a fall, tip-over, or loss of control may occur and cause severe injury to the rider or others.

### I. PUSH HANDLES (Option)

#### WARNING

When you have an attendant, ensure that this chair has push handles.

1. Push handles provide secure points for an attendant to hold the rear of this chair, to prevent a fall or tip-over.
2. Check to ensure push handle grips will not rotate or slip off.

If you fail to heed these warnings damage to your chair, a fall, tip-over, or loss of control may occur and cause severe injury to the rider or others.

### J. QUICK-RELEASE AXLES

#### WARNING

1. Do not use this chair UNLESS you are sure that both quick-release rear axles are locked.
2. An axle is not locked until the quick-release button pops out fully.
3. An unlocked axle may come off during use, resulting in a fall, tip-over, or loss of control and cause severe injury to the rider or others.
4. Quick-Release Axles should be periodically cleaned and inspected for function and signs of wear or bending. Replace as necessary.

If you fail to heed these warnings damage to your chair, a fall, tip-over, or loss of control may occur and cause severe injury to the rider or others.

### K. REAR WHEELS

#### WARNING

A change in set-up of the rear wheels will affect the center of balance of your chair.

1. The farther you move the rear axles FORWARD, the more likely it is that your chair will tip over backward.
2. Consult your health care provider to find the best rear axle set-up for your chair. Do not change the set-up UNLESS you consult your health care provider first.
3. Adjust the rear wheel locks after you make any change to the rear axles.
  - a. If you fail to do so, the wheel locks may not work.
  - b. Ensure lock arms embed in the tires at least 1/8-in when locked.

If you fail to heed these warnings damage to your chair, a fall, tip-over, or loss of control may occur and cause severe injury to the rider or others.

### L. REAR WHEEL LOCKS

#### WARNING

Rear wheel locks are NOT designed to slow or stop a moving wheelchair. Use them only to keep the rear wheels from rolling when your chair is at a complete stop.

1. NEVER use rear wheel locks to try to slow or stop your chair when it is moving. Doing so may cause a fall or tip-over.
2. To keep the rear wheels from rolling, always set both rear wheel locks when you transfer to or from your chair.
3. Low pressure in a rear tire may cause the wheel lock on that side to slip and may allow the wheel to turn when you do not expect it.
4. Ensure lock arms embed in tires at least 1/8-in when locked. If you fail to do so, the locks may not work.

If you fail to heed these warnings damage to your chair, a fall, tip-over, or loss of control may occur and cause severe injury to the rider or others.

### M. MODIFIED SEAT SYSTEMS

#### WARNING

Use of a seat system not approved by Sunrise Medical may alter the center of balance of this chair. This may cause the chair to tip over.

1. Do not change the seat system of your chair UNLESS you consult your Sunrise Medical authorized dealer first.
2. Use of a seating system not approved by Sunrise Medical may affect the backrest folding mechanism of this chair.
3. Use of a seating system not provided by Sunrise Medical is prohibited for transit use.

If you fail to heed these warnings damage to your chair, a fall, tip-over, or loss of control may occur and cause severe injury to the rider or others.

**N. SEAT AND BACK UPHOLSTERY****⚠ WARNING**

1. Replace worn or torn fabric of seat and seat back as soon as you can. If you fail to do so, the seat or seat back may fail.
2. Sling fabric will weaken with age and use. Look for fraying, thin spots, or stretching of fabrics especially at edges and seams.
3. "Dropping down" into your chair will weaken fabric and result in the need to inspect and replace the seat more often.
4. Be aware that laundering or excess moisture will reduce the flame retardation qualities of the fabric.

If you fail to heed these warnings damage to your chair, a fall, tip-over, or loss of control may occur and cause severe injury to the rider or others.

**O. BACKREST TENSION ADJUSTABLE****⚠ WARNING**

The Tension Adjustable Backrest is a versatile back intended to replace standard wheelchair back upholstery. It is designed to provide simple, comfortable, and effective support to help maximize function and increase seating tolerance. In addition, it is lightweight, durable, and easy to use.

Sunrise Medical recommends that a clinician such as a doctor or therapist experienced in seating and positioning be consulted to determine if the Backrest Tension Adjustable is appropriate. Back systems should only be placed by a Sunrise Medical authorized dealer.

**Maximum user weight 300 lbs. (136 kg.)**

**⚠ WARNING**

Placing a back support on a wheelchair may affect the center of gravity of the wheelchair and may cause the wheelchair to tip backwards potentially resulting in injury.

Always assess for the potential need for anti-tippers to be added to the wheelchair to help increase the stability.

**⚠ WARNING**

Do not use the Backrest Tension Adjustable to push or lift the wheelchair. Improper use may cause the back to unexpectedly detach from the wheelchair.

If you fail to heed these warnings damage to your chair, a fall, tip-over, or loss of control may occur and cause severe injury to the rider or others.

**P. FREESTYLE BACK (Option)****⚠ WARNING**

The Freestyle Adjustable Backrest is a versatile back intended to replace wheelchair back upholstery. It is designed to provide simple, comfortable and effective support to help maximize function and increase seating tolerance. In addition, it is lightweight, durable, and easy to use.

Sunrise Medical recommends that a clinician such as a doctor or therapist experienced in seating and positioning be consulted to determine if the Freestyle Backrest is appropriate. Backs should only be placed by a Sunrise Medical authorized dealer.

**Maximum user weight 300 lbs. (136 kg.)**

**⚠ WARNING**

Placing a back support on a wheelchair may affect the center of gravity of the wheelchair and may cause the wheelchair to tip backwards potentially resulting in injury.

Always assess for the potential need for anti-tippers to be added to the wheelchair to help increase the stability.

**⚠ WARNING**

Do not use the Freestyle Adjustable backrest to push or lift the wheelchair. Improper use may cause the back to unexpectedly detach from the wheelchair.

If you fail to heed these warnings damage to your chair, a fall, tip-over, or loss of control may occur and cause severe injury to the rider or others.

**Q. FOLDING LOCK DOWN ANGLE ADJUSTABLE BACKREST****⚠ WARNING**

Only adjust backrest angle when in a safe and stable position. You may increase the likelihood of tipping or instability.

If you fail to heed these warnings damage to your chair, a fall, tip-over, or loss of control may occur and cause severe injury to the rider or others.

**R. SEAT BACK****⚠ WARNING**

Adjusting the seat back depth could cause the strut tube to be located in a position where it could contact the user and cause skin breakdown or other serious injuries.

If you fail to heed these warnings damage to your chair, a fall, tip-over, or loss of control may occur and cause severe injury to the rider or others.

**S. BACKREST - TOWEL BAR****⚠ WARNING**

Extreme impact or force to the backrest towel bar may cause degradation or failure of the towel bar, release bar, or the function of the backrest.

## VIII. USE AND MAINTENANCE

### WARNING

The owner of this chair is responsible for ensuring that it has been set up and adjusted by a trained service professional under the advice of a health care provider. The chair may require periodic safety and function checks or certain in-use adjustments that can be performed by the owner, caregiver, or Sunrise Medical authorized dealer if desired. Always use parts and/or accessories that have been recommended or approved by Sunrise Medical when servicing this chair.

### A. INTRODUCTION

- Proper maintenance will improve performance and extend the useful life of your chair.
- Clean your chair regularly. This will help you find loose or worn parts and make your chair easier to use. You will need a mild detergent solution and plenty of cleaning rags.
- If discovered, have loose, worn, bent, or damaged parts replaced **before using the chair**.
- To protect your investment, have all major maintenance and repair work done by your Sunrise Medical authorized dealer.
- Inspect and maintain this chair strictly per the safety checklist.**
- If you detect a problem, ensure you order parts, or have service, and repair work done at your Sunrise Medical authorized dealer before use.**
- At least once per year, have a complete inspection, safety check, and service of your chair made by a Sunrise Medical authorized dealer.**

### B. CRITICAL SAFETY CHECKS

- Tire Air Pressure:**  
Check air pressure in pneumatic tires at least **ONCE PER WEEK**. The wheel locks will not grip properly if you fail to maintain the air pressure shown on tire sidewall.
- Axles and Axle Sleeves:**  
When checking axles and axle sleeves every six months, ensure they are clean and tight. Loose sleeves will damage the axle plate and will affect performance.
- Camber Tubes and Camber Plugs**  
Inspect the camber tubes and plugs every six months ensuring that all fasteners are tight and that no parts have moved from their preset positions.

### C. CLEANING

- Paint Finish**
  - Clean the painted surfaces with mild soap or detergent at least once a month.
  - Protect the paint with a coat of non-abrasive auto wax every three months.
- Axles and Moving Parts**
  - Clean around axles and moving parts WEEKLY with a slightly damp (not wet) cloth.
  - Wipe off or blow away any fluff, dust, or dirt on axles or moving parts.
- Upholstery**
  - Hand-wash (machine washing may damage fabric).
  - Drip-dry only. DO NOT machine dry as heat will damage fabric.
- Basic Maintenance Materials available at local store**
  - Tire pump
  - Tire pressure gauge
  - Clean rags or cotton cloth.
  - Teflon-based lubricant
  - Mild detergent.

NOTE: You do not need to grease or oil the chair.

### D. SAFETY CHECKLIST

Weekly	3 Months	6 Months	Annually	Safety & Function Check
<input checked="" type="checkbox"/>				Tire Inflation level
<input checked="" type="checkbox"/>				Wheel locks
	<input checked="" type="checkbox"/>			Visually check for loose hardware
		<input checked="" type="checkbox"/>		Armrests
		<input checked="" type="checkbox"/>		Axle and axle sleeves
	<input checked="" type="checkbox"/>			Quick-release axles
	<input checked="" type="checkbox"/>			Wheels, tires, and spokes
	<input checked="" type="checkbox"/>			Casters
	<input checked="" type="checkbox"/>			Anti-tip tubes
		<input checked="" type="checkbox"/>		Frame, camber tubes, and crossbrace
	<input checked="" type="checkbox"/>			Upholstery
			<input checked="" type="checkbox"/>	<b>Service by Sunrise Medical authorized dealer</b>

NOTE: The user or caregiver should perform these weekly and monthly checks to maintain the safety of their chair. If an item is not working properly, please contact your Sunrise Medical authorized dealer.

### E. TROUBLESHOOTING CHART

Symptoms							Solution
	Left turn in chair	Right turn in chair	Looseness in chair	Sluggish turning	Squeaks and rattles	Caster flutter	
<input checked="" type="checkbox"/>	<input checked="" type="checkbox"/>	<input checked="" type="checkbox"/>	<input checked="" type="checkbox"/>				Ensure tire pressure is correct and equal in both rear tires and front caster tires, if pneumatic.
		<input checked="" type="checkbox"/>	<input checked="" type="checkbox"/>	<input checked="" type="checkbox"/>	<input checked="" type="checkbox"/>		Ensure all nuts and bolts are tight.
		<input checked="" type="checkbox"/>		<input checked="" type="checkbox"/>			Ensure all spokes and nipples are tight on radial spoke wheels.
				<input checked="" type="checkbox"/>			Use Tri-Flow Lubricant (Teflon®-based) between frame connections and parts
<input checked="" type="checkbox"/>	<input checked="" type="checkbox"/>		<input checked="" type="checkbox"/>		<input checked="" type="checkbox"/>		Check for proper caster fork adjustment. See instructions for caster fork adjustment.



**F. TO MOUNT AND REMOVE REAR WHEELS** 11 12

**⚠ WARNING**

Do not use this chair UNLESS you are sure both quick-release axles are locked. An unlocked axle may come off during use and cause a fall.

Setting the wheelchair on a flat surface, such as a workbench or table, helps make these procedures easier.

**1. To Install Wheel**

- a. Depress quick-release button (A) fully.
- b. Insert axle (B) through hub of rear wheel.
- c. Keep button (A) depressed as you slide axle (B) into camber plug (C).
- d. Release button to lock axle in camber plug.
- e. Repeat steps on other side.

Note: If axle will not lock properly, service by a Sunrise Medical authorized dealer is required. Refer to section IX:D.

**2. To Remove Wheel**

- a. Depress quick-release button (A) fully.
- b. Remove wheel by sliding axle (B) completely out of camber plug (C).
- c. Repeat steps on other side.

NOTE: The axle is not locked until the quick-release button pops out fully (A). Check that the axle is locked by pulling on the wheel in the direction of the axle.

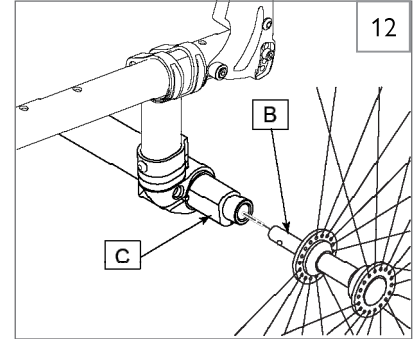
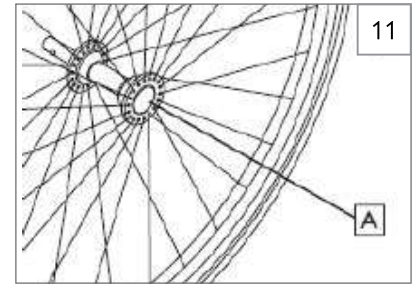

**G. WHEEL LOCKS** 13

**⚠ WARNING**

Wheel locks are installed at Sunrise and should be adjusted by your Sunrise Medical authorized dealer.

Inspect wheel locks weekly per the maintenance chart. Do not use your chair UNLESS you ensure both wheel-locks can fully engage. A wheel-lock that is not correctly adjusted may allow your chair to roll, or turn unexpectedly.

Wheel-locks must be adjusted after ensuring the tires have the correct air pressure. When fully engaged, the arm (D) should be imbedded into the tire at least 1/8-in to be effective.

If you find the wheel locks have slipped or are not working correctly contact your Sunrise Medical authorized dealer for proper adjustment.

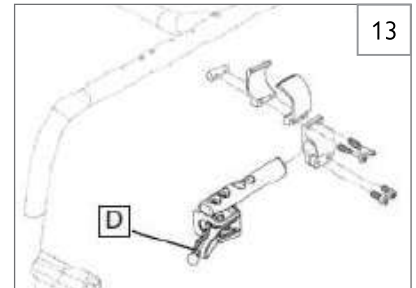

**H. ANTI-TIPS** 14 15

Sunrise Medical recommends anti-tip tubes for all wheelchairs.

**1. Inserting Anti-tip Tubes Into Receiver**

- a. Press the rear anti-tip release button (I) on the anti-tip tube so that both release pins are drawn inside.
- b. Insert the anti-tip tube (E) into the anti-tip receiver (F).
- c. Turn the anti-tip tube down until release pin is through the receiver mounting hole.
- d. Insert second anti-tip tube the same way.

**2. Adjusting Anti-Tip Tube Wheel**

The anti-tip wheels may have to be raised or lowered to achieve proper clearance of 1 1/2 to 2 inches.

Press the anti-tip wheel release button (G) so that both release pins are drawn inside. Raise or lower to one of the five predrilled holes (H). Release button. Adjust the second anti-tip tube wheel the same way. Both wheels should be the same height.

**3. Turning Anti-Tip Tubes Up (Standard Anti-tip)**

Turn anti-tip tubes up when being pushed by attendant, overcoming obstacles or climbing curbs. Press the rear anti-tip tube release button (I). Hold lever in and turn anti-tip tube up. Release the lever and repeat with second anti-tip tube. Remember to return anti-tip tubes to down position after completing maneuver.

**4. Turning Anti-Tip Tubes Up (Single Side Flip-up Anti-tip)**

To position the Single Side Flip-up Anti-tip in the Up position, firmly press the upper anti-tip tube (J) towards the front of the chair. While pressing firmly to release locking pin, rotate anti-tip (J) 90° towards the center of the chair until the locking pin is secured in place.

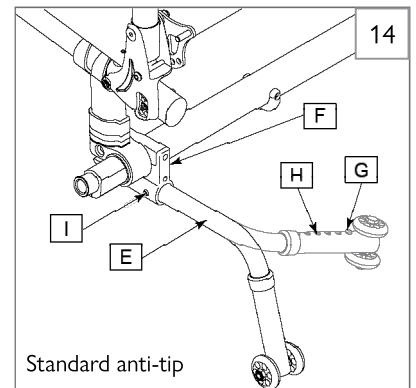

Standard anti-tip

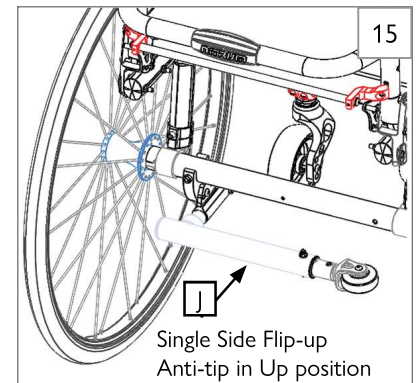

Single Side Flip-up Anti-tip in Up position



## VIII. USE AND MAINTENANCE

### I. SINGLE POST HEIGHT-ADJUSTABLE ARMRESTS (Option) 16

Sunrise Medical offers several different types of armrests. Fixed, Swing-away, and Flip-back armrests. Swing-away armrests can be detached or can swing away to allow lateral transfers. They are height adjustable (1-in increments)

#### 1. Basic Installation

- Slide the outer armpost (1) into the receiver (7) mounted to the wheelchair frame.
- The armrest should lock into place.

#### 2. Height Adjustment

- Release the upper securing lever: (2)
- Slide armpad (4) up or down to desired height.
- Return lever (2) to locked position.

#### 3. Removing the Armrest

- Squeeze the release lever (3) and remove the armrest from the receiver (7).

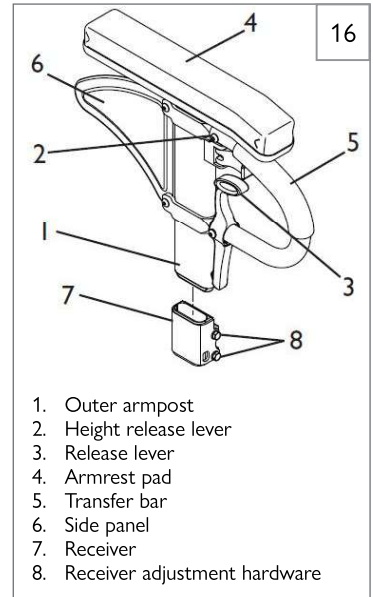

### J. PADDED SWING-AWAY ARMRESTS (Option) 17

#### 1. Installation

- The armrest height is determined by the adjustment bolt (A) position.
- Slide the armrest into the receiver tube (B) on rear of frame until the adjustment bolt is securely seated (locked) in the receiver tube slot.

#### 2. Swinging Away

- Lift armrest out of the locked position and rotate to the side

#### 3. Removing Armrest

- Pull armrest straight out of the receiver.

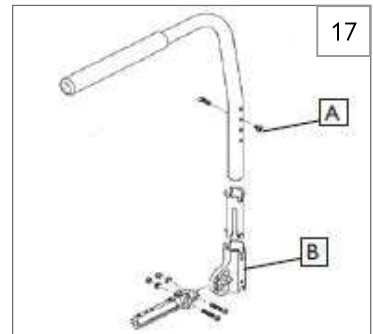

### K. FLIP-UP FOOTPLATE (Option) 18

The footplate (C) can be rotated up towards the user for transfers and adjustment.

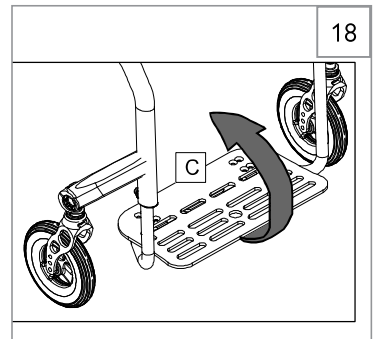

### L. FREESTYLE BACK (Option) 19

#### Back pad Installation

- Wrap the Backpad (D) around the back shell (E) as shown.
- Attach the hook and loop fastener straps so that the pad is secure.

#### **⚠️ WARNING**

Ensure that your Sunrise Medical authorized dealer, when doing regular maintenance, tightens the back hardware to the torque specified in section IX-N. Do not use this chair UNLESS you ensure the adjustments are locked in to this torque.

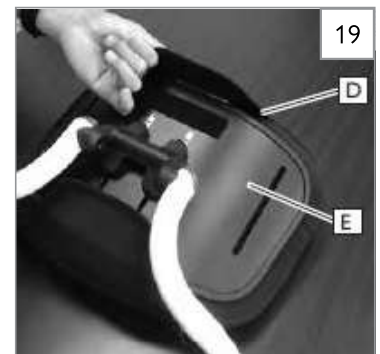

**M. BACK ANGLE PERFORMANCE** 20 21

**Adjusting the Angle of the Backrest**

1. While the user is out of the chair, use a 4mm Allen wrench and remove bolt (A) from both the right and left backrest bracket. (Fig. 20)
2. Each of the backrest brackets has a number of holes to allow you to choose different backrest angles. Once you have determined your new angle, reattach bolts (A) into the new holes in the backrest brackets. With a 4mm Allen wrench and 8mm wrench, secure both bolts to 5 Nm [44 in-lbs].



**Folding and Unfolding the Backrest**

1. Release the backrest to fold the back down by pulling up on the release bar: (B) (Fig. 21)
2. To re-secure the backrest, pull up on the backrest towel bar until it locks back into the upright position. There is also a second (optional) way to fold the backrest down or back up. If the chair is equipped with this option, there is a grip (C) that is located in the middle of the towel bar, that you can rotate forward and the backrest can be folded down or back up. (Fig. 21)



**⚠ WARNING**

**Towel Bar Use**

Extreme impact or force to the backrest towel bar may cause degradation or failure of the towel bar, release bar, or the function of the backrest. Use caution when backing the chair up where the towel bar handle (C), or release bar (B) may come into contact or rub up along something to allow the back to unintentionally fold down. (Fig. 21)

**N. TENSION ADJUSTABLE UPHOLSTERY** 22 23 24 25

**Installing Standard Tension Adjustable Backrest Upholstery**

1. Slide hook and loop fastener straps (F) over the backrest frame (G) section. Ensure you include at least one strap below the towel bar (if using a rigid chair).
2. Tighten the straps appropriately to desired tension level. DO NOT over tighten straps as this will cause undue strain upon the chair backrest frame (G).
3. If using fold down push handles, insert the single hook and loop fastener strap (F) through the slots in the front of the push handles (I).  
If using integral push handles (J), slide straps from bottom of backrest upward.
4. Install backrest cover at desired level and fold over rear of hook and loop fastener strapping system (K). The Quickie patch should be upright on the rear of the chair.
5. Finish installation by placing vanity flap (center panel) down onto hook and loop fastener on the seat sling to secure attachment (L).

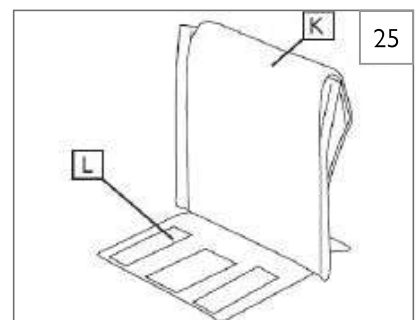
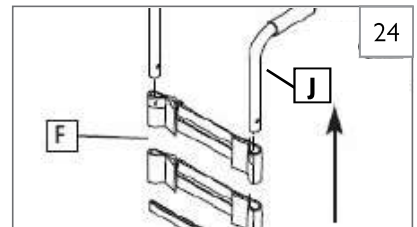
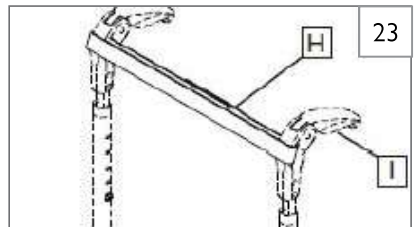
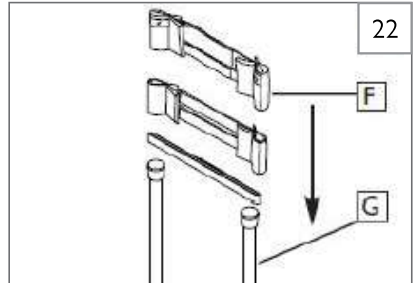

**⚠ WARNING**

Any changes made to the straps will affect the center of gravity. It is best to have the attendant stationed behind the wheelchair to prevent the wheelchair from tipping backwards while the user becomes accustomed to the adjustment.

## VIII. USE AND MAINTENANCE

### O. SEAT SLING ADJUSTMENT 26

Remove the screws (A) retaining the left side seat sling. Readjust hook and loop fastener style material to increase the tension in the seat sling. Replace screws. If there is any difficulty in reattaching the screws, try using a probe to help align the holes. Ensure that the plastic saddles (B) are under the seat rail in all fastener positions.

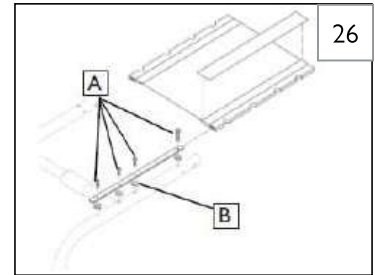

### P. TENSION ADJUSTABLE SEAT SLING 27

The Tension Adjustable Seat Sling may be removed by first loosening the hook and loop fastener straps (C) that encircle the chair frame. All straps must be attached again in the same position and quantity as the original set-up.

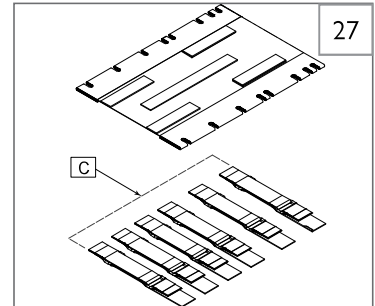

### Q. CUSHION INSTALLATION

Place cushion on seat sling with hook and loop fastener side down. The beveled edge of the cushion should be in front. Press firmly into place.

### R. STORAGE TIPS

1. Store your chair in a clean, dry area. If you fail to do so, parts may rust or corrode.
2. Before using your chair, ensure it is in proper working order.
3. Inspect and service all items on the Safety Checklist (Section VIII-D).
4. If stored for more than three months, have your chair inspected by a Sunrise Medical authorized dealer before use.

**S. LED AND BATTERY PACK** 28 29 30 31 32

Switching the lights on:

Push button (A) on top of the control box to cycle through operating modes of the LEDs:

1. Full power mode
2. Low-power mode
3. Flash-mode
4. Off

The charging status of the battery is indicated by the backlit button (A):

- red: charging-status <50%
- red (when battery is connected to the charger): battery is charging
- green (when battery is connected to the charger): battery fully charged

Remove the control box from the calf strap for charging:

Detach cables on the sides by gently pulling the pins out of the connectors (C). Now pull the control-box upwards to remove it from the calf strap.

Charge the battery:

Connect the USB cable to the connector (B) on the front side of the control box. Use a standard USB charger or your computer's USB port to charge the battery. Green light will indicate a fully charged battery.

Battery Specification	
Battery-type	Lithium-Ion
Nominal capacity	2600mAh
Nominal voltage	3.6V
Charging-time	3hrs

Checking batteries

1. Before using LED for the very first time, please charge your batteries for a period of 24 hours.
2. Are the batteries sufficiently charged? The green lights on the battery indicator must be on.

Attach to Chair:

1. Attach calf strap to chair.
2. Clean adhesive surfaces for LED light with LOCTITE® SF7063.
3. LED light screw positioning, pressing, and screwing, pointing cable towards frame. (Fig. 29)
4. Lay the cable in calf strap as shown. (Fig. 30)
5. Attach the calf strap cover to the rear and shorten it to length, cutting edge immediately to the right of the sewn field. (Fig. 31)
6. Clip the battery pack into calf strap, mount the plug, place remaining cable in the calf strap and attach the cable ties.

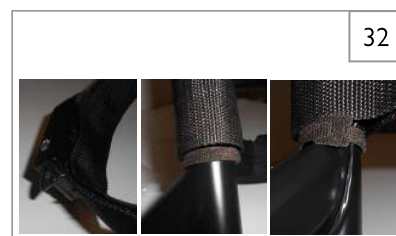
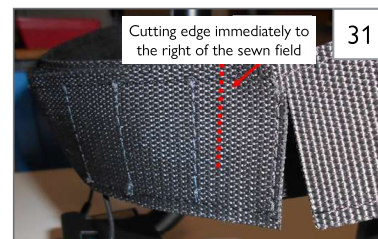
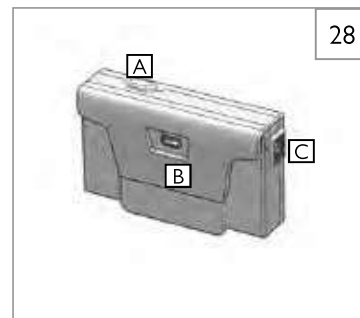

**T. CHECK OUT**

After the wheelchair is assembled and adjusted, it should roll smoothly and easily. All accessories should also perform smoothly. If you have any problems, follow these procedures:

1. Review the set-up and check-out sections and operating guide to ensure chair was properly prepared.
2. Review the troubleshooting chart at the beginning of this section.
3. If your problem persists, contact your Sunrise Medical authorized dealer. If you still have a problem after contacting your authorized dealer, contact Sunrise Medical customer service. See the Introduction Page for details on how to contact your authorized dealer or Sunrise Medical customer service.

## IX. DEALER SERVICE AND ADJUSTMENT

### WARNING

The owner of this chair is responsible for ensuring that it has been setup and adjusted by a trained service professional under the advice of a health care provider. Service and/or adjustments should only be done with the advice of a health care provider. Always use parts and/or accessories that have been recommended and approved by Sunrise Medical when servicing this chair.

### A. DEALER SERVICE INTRODUCTION 33

- At least once per year, this chair should have a complete inspection, safety check, and regular service made by a Sunrise Medical authorized dealer. The tool list at right is a good starting point for proper maintenance.
- If you have discovered a worn, bent, or damaged part, repair or replace them with recommended parts before returning this chair to service.
- All major maintenance and repair work should be done by a Sunrise Medical authorized dealer.

### B. CRITICAL MAINTENANCE TIPS

- Torque settings:  
A torque setting is the optimum tightening which should be made on a particular fastener. It is important to use proper torque settings where specified. When not specified, torque settings should be 6.78 Nm [60 in-lbs].
- Dealer Service and Adjustment Reference materials:  
Go to [www.SunriseMedical.com](http://www.SunriseMedical.com) for parts manuals, instruction sheets, and instructional videos that will aid in the repair of your Quickie wheelchair.

### C. CLEANING

- Paint Finish
  - Clean the painted surfaces with mild soap or detergent.
  - Protect the paint with a coat of non-abrasive auto wax.
- Axles and Moving Parts
  - Clean around axles and moving parts with a slightly damp (not wet) cloth.
  - Wipe off or blow away any fluff, dust or dirt on axles or moving parts.
  - DO NOT USE 3-in-ONE oil, or WD-40® for lubrication. Only use Teflon® based Lubricant when working on this wheelchair.

### D. REAR WHEEL AXLE NUT ADJUSTMENT 34 35

The rear wheel axle (B) attaches the rear wheel (D) to the camber plug (C). When the detent balls (E) engage into the camber plug the rear wheel effectively becomes locked onto the chair. Pushing the quick-release button (A) disengages the detent balls and allows removal of the axle and wheel assembly.

To adjust the axle you will need a 3/4-inch wrench to turn the adjustment nut (F). You will also need a 1/2-inch wrench to securely hold the ball detent end of the axle to prevent it from turning.

If the wheel and axle will not lock into the camber plug then the axle requires adjustment. Turn the nut counter-clockwise approximately 1/4 revolution and try to lock the axle into the camber plug. If it doesn't lock, continue making small nut adjustments until it securely locks.

If the wheel is locked on the chair but there is excessive wheel play (the wheel hub can be pushed back and forth on the axle) then adjust the nut clockwise until there is no perceptible gap between the wheel and camber tube and the axle is securely locked onto the chair.

### E. ANTI-TIP RECEIVER 36

Sunrise Medical recommends anti-tip tubes for all wheelchairs.

- After attaching the Anti-tip receiver (G) ensure that the receiver is parallel with the ground, and the bolts are tightened so that the anti-tips do not move when used.
- Ensure that the guide/locking pins are engaged before use.

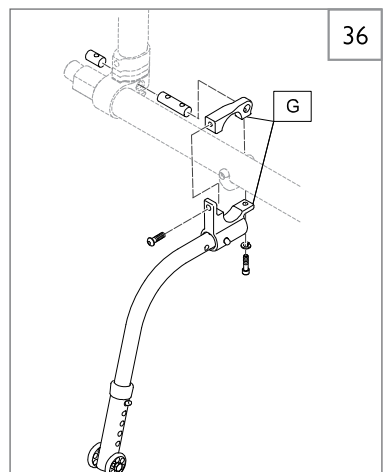
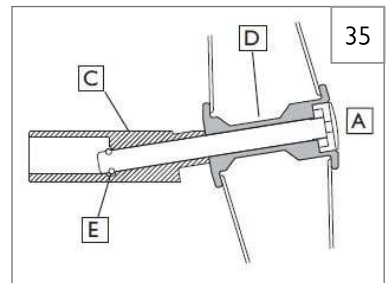
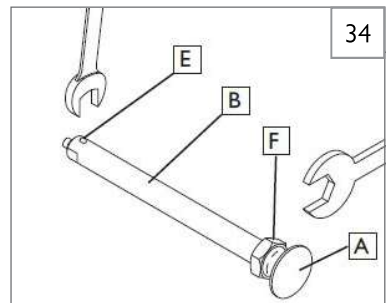



**F. WHEEL LOCKS** 37 38

The Quickie Nitrum wheelchair is equipped with a variety of different wheel locks. Below are a few of them. Wheel locks are installed at the factory unless you have requested otherwise.

Use a torque setting of 7 Nm [62 in.-lbs] when setting up wheel locks.



1. High-Mount Push-to-Lock Wheel Locks Adjustment 37

- a. Using a 4mm Allen wrench, turn one of the screws (A) in the clamp counterclockwise one-quarter turn.
- b. Repeat the same process with the remaining screw (A).
- c. Alternately loosen the screws (two turns each) until both screws are loose.
- d. Slide clamp toward the rear wheel until the wheel lock is embedded into the tire to prevent wheel movement, when in the locked position.
- e. Tighten screws to 7 Nm [62 in.-lbs].

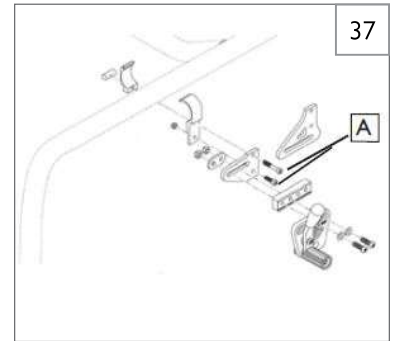

2. Compact Wheel Locks 38

- a. Using a 4mm Allen wrench, turn one of the screws (A) in the clamp counterclockwise one-quarter turn.
- b. Repeat the same process with the remaining three screws (A).
- c. Alternately loosen the screws (two turns each) until both screws are loose.
- d. Slide clamp toward the rear wheel until the wheel lock is embedded into the tire to prevent wheel movement, when in the locked position.
- e. Adjust angle position.
- f. Tighten screws to 7 Nm [62 in.-lbs].

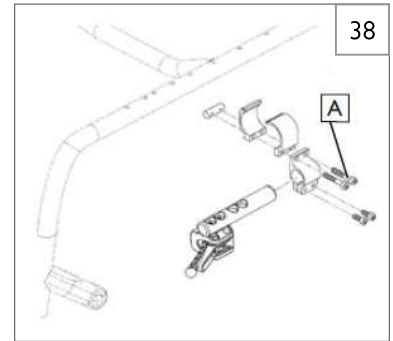

NOTE: Clamp and wheel lock may need to be rotated to clear frame tubing.

**G. ARMREST RECEIVER ATTACHMENT**

Adjusting Armrest Receiver Fit 39 40

To tighten or loosen the fit of the outer armpost in the receiver (C):

1. Loosen the four receiver adjustment bolts (D) on the sides of the receiver.
2. With the armrest in the receiver (C), squeeze the receiver to achieve the desired fit.
3. Tighten the four bolts (D) to 16.3 Nm [144 in.-lbs].

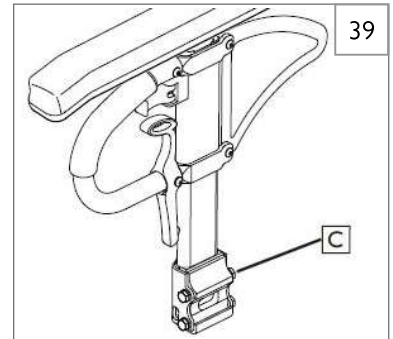

Position Adjustment 41

1. Loosen the two clamp bolts (E) until clamp is loose.
2. Slide armrest receiver to desired position.
3. Tighten both bolts (E and F) to 7 Nm [62 in.-lbs].

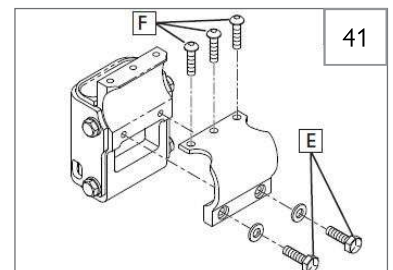
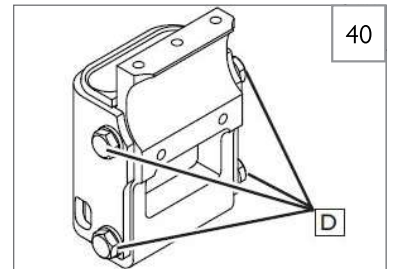



## IX. DEALER SERVICE AND ADJUSTMENT

### H. PADDED SWING-AWAY ARMRESTS (OPTION) 42

Swing-away armrests can be detached or can swing away to allow lateral transfers. They are height adjustable (6 inches in 1-inch increments) by moving bolts (G) up or down in predrilled holes on armrest.

1. Height adjustment
  - a. Pull armrest straight out of the receiver.
  - b. Remove the indexing Bolt (G) and move it to the desired adjustment hole.
  - c. If more height adjustment is required, the bracket can be inverted and reattached.
  - d. Tighten the hardware to 7.12 Nm [63 in-lbs].
2. Angle adjustment
  - a. To change the angle of the armrest, remove the Bolts (H).
  - b. Reposition to the required angle, Attach again the hardware.
  - c. Tighten the hardware to 7.12 Nm [63 in-lbs].

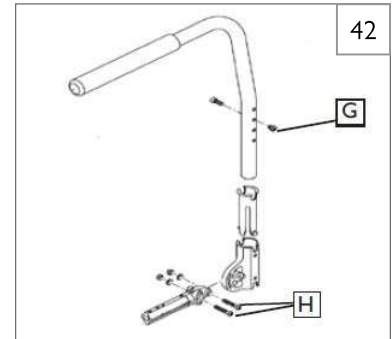

### I. CASTERS 43 44

Setting the wheelchair on a very flat table or a workbench makes this setting more accurate.

1. Correcting a Pull to the Right or Left
 

Determine which direction the chair is pulling (right or left). Make the following adjustments to the caster on that side of the chair:

  - a. The adjustment required will be to lengthen or shorten one or both of the fork stems. (Fig. 43)
  - b. If the chair is pulling to the right, you will need to lengthen the right fork stem. If the chair is pulling to the left, you will need to lengthen the left fork stem. The side with the pull will typically be making less contact with the ground than the opposite side, and the caster wheel on that same side may even float.
  - c. To make this adjustment, insert special tool (torque wrench p/n 66009203) into a 3/8-in torque wrench. Loosen the jam nut on the fork stem (A). Lengthen or shorten the caster stem using the 18mm open-end spanner wrench (p/n 66009205) as needed. When completely finished with adjustments, torque jam nut (A) to 28 Nm [20.65 ft-lbs]. (Fig. 44)

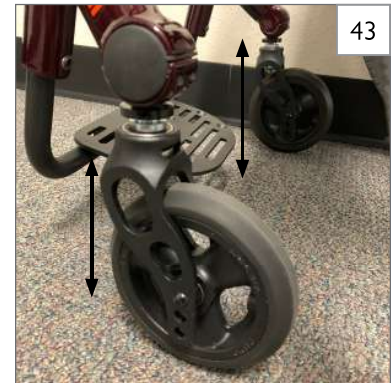

**J. CASTER FORK ADJUSTMENT** 45 46

Adjusting Caster Fork Angle, Directional Stability, and Caster Fork Height:

The caster fork adjustment has three settings: Caster Fork Angle, Directional Stability, and Caster Fork Height. The settings for directional stability are combined: by twisting the slightly angled caster axle (A) (Fig. 45), the fork moves inward (B) or outward (C) (Fig. 46). At the same time, the height of the fork also changes by 1 mm for every full rotation of the caster axle.

The detailed instructions for making the adjustments are described in the following section.

NOTE: the following adjustments may only be made by Sunrise Medical authorized dealers.

NOTE: a service video about this can be found on the Sunrise Medical YouTube channel.

**⚠ WARNING**

Faulty adjustments, or adjustments that have not been carried out correctly, may cause damage to the wheelchair or result in a fall and severe injuries to the user and other people.

Wherever torque settings are specified, it is strongly recommended that a torque wrench (not included) be used to verify correct torque specification is achieved.

Some of the screws that are used during manufacture are fitted with threadlock (blue or yellow dot on the thread) and can be undone and tightened again up to three times before they must be replaced with new screws and threadlock. Alternatively, apply Loctite™ 243 threadlock on the screws and re-fit them.

**1. Setting the directional stability:** 47 48 49

- a. Insert special tool (torque wrench, p/n 66009203) into a 3/8-in torque wrench.
- b. Undo the round nut between the fork and caster connection with the Spanner Wrench (Fig. 47).
- c. Rotate the caster inward, place a 90° setting gauge on the front of the fork and grasp the caster axle between the round nut and the fork with a 18mm open-end spanner wrench (p/n 66009205) and rotate it until the front of the fork is level with the setting gauge (Fig. 48 and Fig. 49). To do this, rotate it by a maximum of 90° in one direction, to avoid accidentally changing the height.
- d. After the adjustment has been made, keep the caster axle in position with the open-end spanner while tightening the round nut to a torque of 28 Nm [20.65 ft-lbs].



Note: The fork angle must be set after adjustment has been made (see J.3: Setting the caster fork angle).

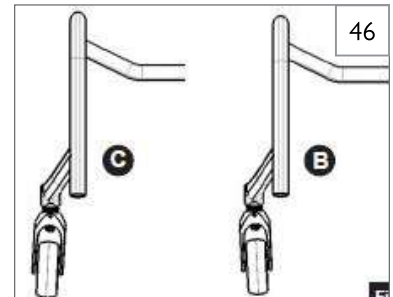
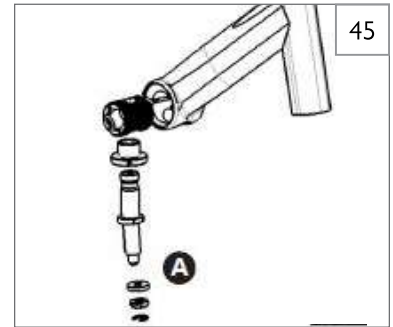

## IX. DEALER SERVICE AND ADJUSTMENT

### 2. Adjusting the height

If the wheelchair does not stand properly on 4 wheels, i.e. one of the casters is not completely touching the floor, the height of this caster should be adjusted as follows:

- Place the wheelchair on a flat surface, such as a worktop or similar.
- Load the footrest with a weight of approximately 2.2-lbs (1 kg), ensure that the air pressure is identical in both drive wheels, and rotate both casters into the straight line position (casters pointing to the back).
- Insert special tool (torque wrench, p/n 66009203) into a 3/8-in torque wrench.
- Undo the round nut between the fork and caster connection with the spanner wrench.
- Grasp the caster axle between the round nut and fork with a 18mm open-end spanner wrench (p/n 66009205) and rotate it counterclockwise. The caster will be lowered by 1mm with each complete turn (360°).
- If the caster axle is rotated by one complete turn (360°), this will not influence the directional stability. In all other cases, the directional stability must be adjusted again.  
See: "1. Setting the directional stability" for more on this.
- Adjust the caster axle until all 4 wheelchair wheels are standing firmly on the ground.
- After the adjustment has been made, keep the caster axle in position with the open-end spanner wrench while tightening the round nut to a torque of 28 Nm [20.65 ft-lbs].

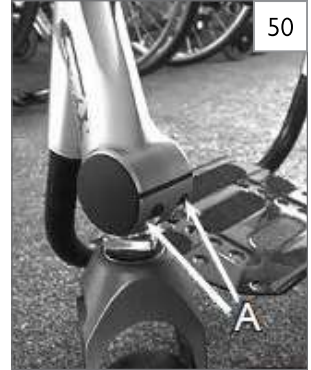

### 3. Adjusting the caster fork angle

50 51

This adjustment is necessary if the seat height/center of gravity has been changed, or the directional stability has been adjusted.

#### **⚠ WARNING**

An incorrectly adjusted caster fork angle may cause the casters to wobble, and lead to the user falling or severe injuries.

Setting the fork to trailing (fork is inclined toward the back in the direction of travel) will increase the probability of the casters wobbling. Setting it to leading (fork is inclined toward the front in the direction of travel) can reduce the probability of the casters wobbling.

- Loosen the Allen screws (A) (Fig. 50). The caster fork angle can now be adjusted to the front (leading) or to the back (trailing).
- To ensure caster fork is in an exactly horizontal position (90° to the floor, neither leading or trailing), use a squaring gauge (e.g. 90° flat angle, set square). Rotate the casters in the travelling position and place the squaring gauge on the flat front side of the fork (Fig. 51). The caster fork will be at an angle of 90° to the floor when the squaring gauge covers the entire surface.
- To set the fork slightly to leading, e.g. to prevent the caster fork from wobbling, set the angle so that a slight light gap can be seen between the squaring gauge and contact area.
- When position is set correct, tighten again the Allen screws (A) using the following procedure. Tighten the outer allen screw first to a torque of 7 Nm [62 in-lbs]. Then, tighten the inner allen screw to a torque of 7 Nm [62 in-lbs]. Repeat this procedure up to 6 times until both allen screws are evenly tightened to a torque of 7 Nm [62 in-lbs].



### 4. Replacing the caster fork

52

- Remove the locking clip (B) at the lower end of the caster axle.
- Remove the nut (C) with a 13 mm open-end wrench.
- Now replace the fork.
- Assemble again by following the instructions in reverse order.
- Torque nut (C) to 10 Nm [88.51 in-lbs].

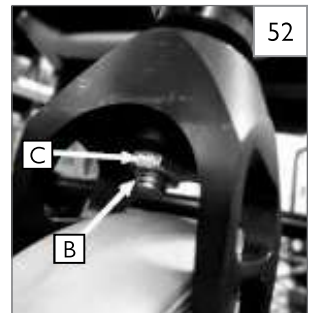

**K. FOOTREST HEIGHT ADJUSTMENT** 53 54 55 56



**WARNING**

The footrest is an integral part of the frame. Chair should not be ridden without a footrest.

To adjust the height of your footrest, loosen the screws (H) on both footrest down tubes. Slide the footrest up or down to the new desired height and tighten the two set screws. Use a MAX torque setting of 7 Nm [62 in-lbs] (Frame damage may occur if overtightened). It is recommended that you maintain a minimum of 2.0 inches (5 cm) between the lowest point on the footrest and the floor (I). This will provide adequate clearance for uneven surfaces and prevent damage to your footrest.

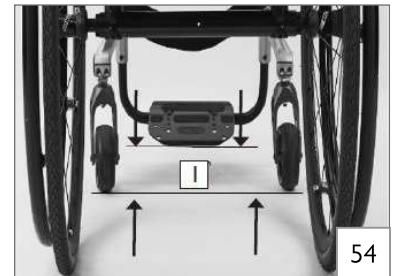
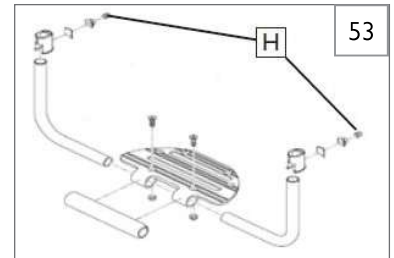

1. Flip-up Footrest 55

To adjust the angle of the Flip-up Footrest, loosen two bolts (J) and rotate the footrest angle stop bracket. Once positioned, retighten bolts (J) to 10.39 Nm [92 in-lbs]. For certain narrow widths, only one bolt will be present.

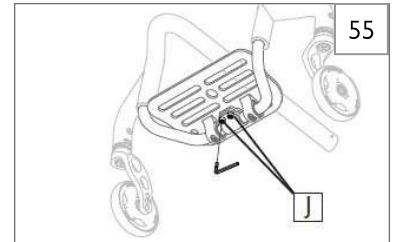

2. High Mount Footrest Mount 56

- a. Loosen all four socket heads (K) on both sides of the chair.
- b. Slide footrest to desired height.
- c. Tighten socket to 7 Nm [62 in-lbs] on both sides.

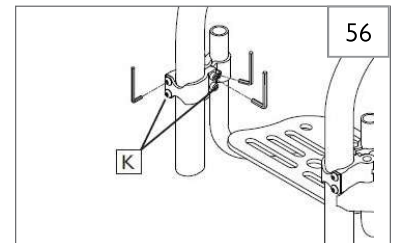

**L. ADJUSTING REAR SEAT HEIGHT** 57 58

NOTE: Adjustment to rear seat height may also require caster angle adjustment. See Section IX-P.

NOTE: If chair is configured with the 1B axle plate, the shorter camber tube clamps will be needed to lower rear seat height by 1/2 inch. If configured with a 1A axle plate, it cannot be lowered and needs longer camber tube clamps in order to raise seat height

1. Remove the set screws (A) on the rear side of the axle plate and the button head screw (B) on the front.
2. To increase the Seat To Floor Height add a spacer (C) to the camber tube clamp (D).
3. To reduce the Seat To Floor Height remove the spacer (C) from the camber tube clamp (D).
4. No more than two spacers per side are to be used. Once complete, insert the camber system (D) in the axle plate. Tighten the left allen screw first to a torque of 7 Nm [62 in-lbs]. Then, tighten the right allen screw to a torque of 7 Nm [62 in-lbs]. Repeat this procedure up to six times until both allen screws are evenly tightened.

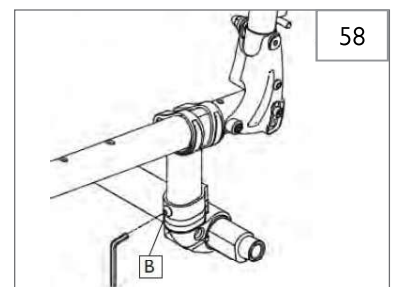
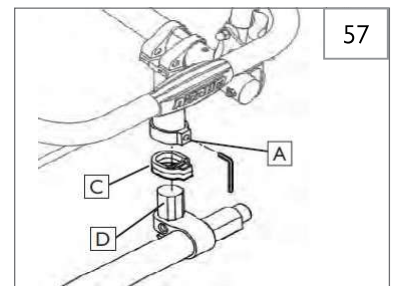

## IX. DEALER SERVICE AND ADJUSTMENT

**M. BACKREST** 59 60 61**1. Angle-adjustable back**

Remove allen screws (A) on both backrest tubes. Adjust angle within the hole-pattern (3° increment per hole), insert allen screws (A) on both sides and tighten to 5 Nm [44.25 in-lbs] (Fig. 59).

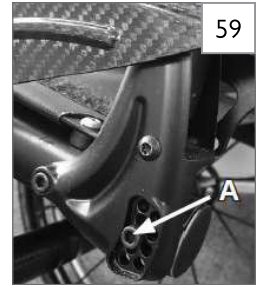
**2. Folding backrest**

The backrest is foldable, two versions of the release mechanism are available.

- Pushbar - release: push the release bar upwards, hold the position and fold the backrest forward.
- Twist-lock release: rotate the handle on the crossbar forward, hold the position and fold backrest forward. The handle can only be rotated in the forward direction.

**3. Double-locking option**

This option is available on the backrest- if the wheelchair is equipped with double-locking option, the backrest will lock in the flat-folded position.

- To unfold the backrest, either push the pushbar upwards or rotate the twist-lock handle forward.
- The locking position (angle) of the folded backrest can be adjusted: remove allen-screw (B) on both sides (Fig. 60), set the desired locking angle by choosing the corresponding hole within the hole-pattern (C) (Fig. 61) and tighten again allen screws (B) on both sides to 5 Nm [44.25 in-lbs].

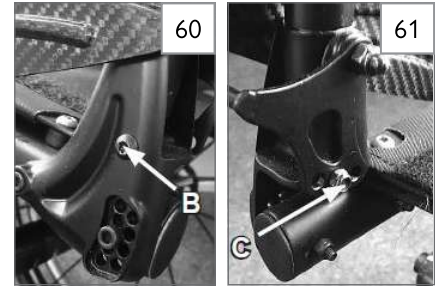
**N. FREESTYLE BACK MAINTENANCE AND ADJUSTMENT** 62 63 64**1. When performing regular maintenance, check the torque on the Freestyle back.**

- Using a torque wrench check and tighten if needed the hardware (E) (F) to 22.6 Nm [200 in-lbs] to ensure the back shell is locked into position.

**2. Height adjustment**

- Remove the cover and back pad to gain access to the adjustment hardware.
- Using a 4mm hex key, loosen the 4 screws (G) and move the back shell up or down to desired height. (Fig. 63) Tighten the screws to lock in the adjustment.
- Attach again the back pad and cover.

**3. Fine depth and height adjustment**

The Freestyle back adjustment system provides a maximum of 1 inch of fine depth adjustment combined with a maximum of 1 inch of fine height adjustment.

- Using a 8mm hex key, loosen the two screws (F) and rotate the backshell to the desired position.
- Tighten the screws (F) to 22.6 Nm [200 in-lbs] to lock in the adjustment.

**4. Angle adjustment**

The Freestyle back adjustment system allows the ability to adjust the backrest angle to achieve user's comfort and position.

- Using a 8mm hex key, loosen the screw (E) and rotate the backrest to the desired position.
- Tighten the screw (E) to 22.6 Nm [200 in-lbs] to lock in the adjustment.

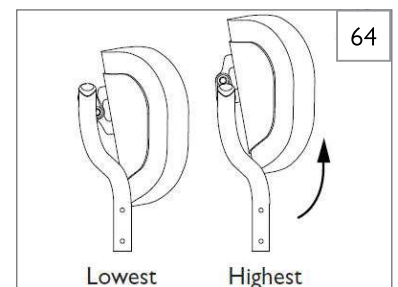
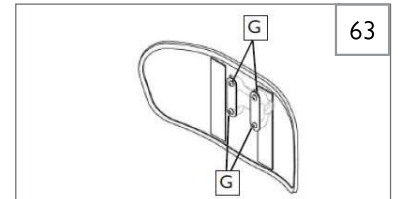
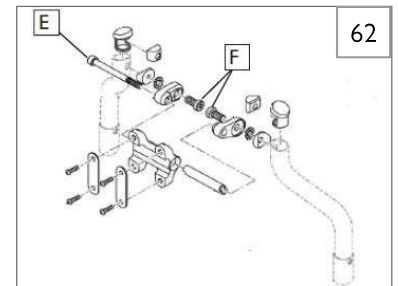



**O. 4-LINK REAR SUSPENSION** 65 66 67

**⚠ WARNING**

Rear suspension can affect the stability of the wheelchair. To avoid a fall, use a spotter and/or antitips when becoming familiar with new equipment.

**1. Tuning the 4-Link Rear Suspension**

- a. To stiffen the suspension, turn the spring preload adjustor (A) clockwise (looking up at the suspension system from underneath the wheelchair).
- b. To soften the suspension, turn the spring preload adjustor (A) counter-clockwise (looking up at the suspension system from underneath the wheelchair).

**2. Alignment of Suspension Link Arms**

Do not adjust the link arms (B). These are set at the factory to ensure proper tracking and performance of the 4-Link Rear Suspension system.

**3. Setting the Toe to Zero**

Loosen the cap screws (C) (3 per side, unless equipped with anti-tips then 4 per side) that secure the camber tube clamp. Observe the ball in the level (F), and rotate the camber tube (D) until the ball is centered in the level. The toe is now set at zero.

Before tightening the screws (C), ensure that the camber tube is centered left-to-right relative to the wheelchair frame, and the flat portions underneath outer camber tube clamp are parallel side to side. The end of the camber tube should be flush with the outer most portion of the camber tube clamp. Torque fasteners (C) to 7 Nm [62 in-lbs].



**4. Setting the Toe to Zero– Alternative Method**

Place the entire wheelchair on a flat horizontal table or ground surface. Loosen the cap screws (C) (3 per side, unless equipped with anti-tips then 4 per side) that secure the camber tube clamp. Locate the flat surfaces on the front and rear of the camber plugs. Place an object that is known to have an accurate 90° corner (such as a carpenter's square, drafting triangle, etc.) down on the flat horizontal surface and up against the flat of the camber plug. Rotate the camber tube and plug assembly until the flat surface of the camber plug (G) is parallel to the measuring tool.

Before tightening the screws (C), ensure that the camber tube is centered left-to-right relative to the wheelchair frame and the flat portions underneath outer camber tube clamp are parallel side to side. The end of the camber tube should be flush with the outer most portion of the camber tube clamp. Torque the fasteners to 7 Nm [62 in-lbs].



NOTE: When turning the 4-Link Rear Suspension, always make one change at a time and write down the change. This takes patience but allows you to understand how each change affects the ride of the wheelchair in conjunction with rear suspension.

NOTE: Lower shock mount is designed to have a loose feel, this is by design to allow for proper suspension travel.

NOTE: Never remove the barrel nut (E) that connects camber clamp to the shock camber clamp.

**5. Maintenance for the 4-link suspension**

- a. Do not apply lubrication to shock end bushings or coils.
- b. You can apply lubrication to the link ends after cleaning with a mild soap and soft brush.
- c. Use a soft brush to clear any dirt or debris from coil system.
- d. Never use a high-powered washer for cleaning the 4-Link Rear Suspension.

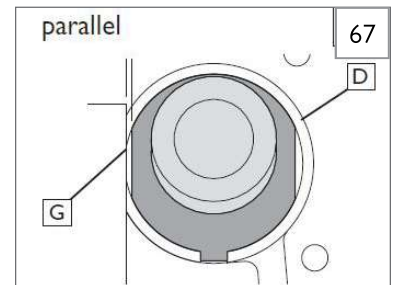
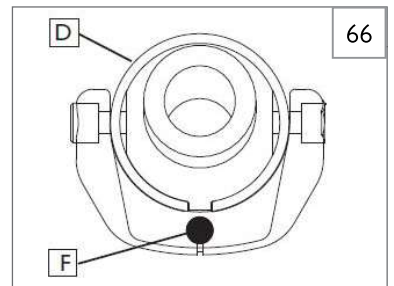
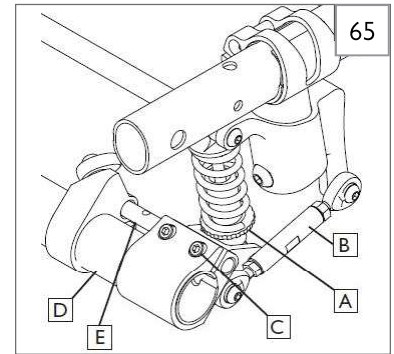



## IX. DEALER SERVICE AND ADJUSTMENT

### P. REAR AXLE

The most important adjustment on your wheelchair is the position of the rear axle. The center of gravity and wheel camber are determined by the axle adjustment.

#### 1. Center of Gravity Adjustment



#### WARNING

The more you move your rear wheels forward, the more likely your chair will tip over backwards. Always make adjustments in small increments, and check the stability of your chair with a spotter to prevent a tip-over. We recommend that you use anti-tip tubes until you adapt to the change and are sure you are not at risk to tip over. Refer to additional Warnings in Section VI "Falls and Tip Over".

Changes to the center of gravity may affect the rear seat height (Section IX-L), toe-in/toe-out of the rear wheels (Section IX, O-3) and the squareness of the casters. If you change your center of gravity position, readjust all of these settings if necessary. Refer to Section IX-].

Adjusting your chair's center of gravity will require re-adjusting the location of the wheel locks (if provided). See Section IX-F for instructions on adjusting the wheel locks.

Range of adjustment can be limited by chair configuration and options selected.

##### a. Adjusting the Center of Gravity: Open Frame 68

You can adjust your center of gravity position by moving the two axle plate clamps (A) forward or rearward on the seat tube (B). Moving the axle plate clamps forward shortens the wheelbase and lightens the front end, making your chair more maneuverable. Moving the axle plates rearward makes the chair more stable and less likely to tip over rearward.

- i. To adjust the center of gravity location, remove both rear wheels.
- ii. Loosen the 4 screws (C) (2 per side) that secure the axle plates (A) to the seat tubes. Slide both axle clamps forward or rearward along the seat tube to the desired position. Ensure both sides are adjusted symmetrically before tightening screws. Tighten screws to 7 Nm [62 in-lbs].
- iii. Once the axle plate clamps are secured, attach the rear wheels.
- iv. Occupy the chair and maneuver it with a spotter to get a feel for the new adjustment.

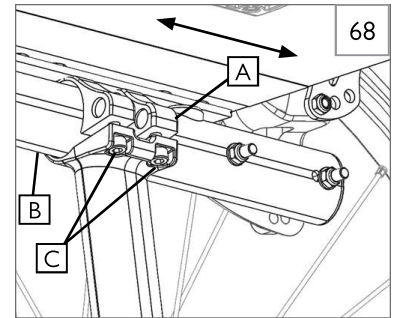

##### b. Adjusting the Center of Gravity: Active Rigid Frame 69

NOTE: Active Camber Setup: Axle plate is welded per Center of Gravity requirement, per order.  
NOTE: Camber clamp to be centered on camber tube mount except when the Center of Gravity is set at 0.5-in or 4.0-in.

You can adjust the center of gravity position by moving the camber tube clamps (D) forward or rearward on the camber tube mount (F). Moving the camber tube clamps forward shortens the wheelbase and lightens the front end, making your chair more maneuverable. Moving the camber tube clamps rearward makes the chair more stable and less likely to tip over rearward.

- i. To adjust the center of gravity location, remove both rear wheels.
- ii. Remove the 4 screws (E) (2 per side) that secure the camber tube clamp to the camber tube mount (F). Slide both camber tube clamps forward or rearward (keeping even on both sides) to the desired position ensuring that holes in the camber tube clamp line up with the camber tube mount. Ensure both sides are adjusted symmetrically before tightening screws. Tighten screws to 7 Nm [62 in-lbs].
- iii. Once the camber tube clamps are secured, attach the rear wheels.
- iv. Occupy the chair and maneuver it with a spotter to get a feel for the new adjustment.

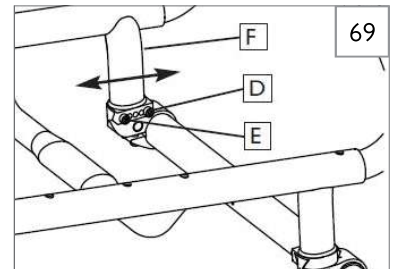

#### 2. Wheel Camber 70

Wheel camber, shown as angular relationship (G), provides greater side-to-side stability due to the increased width and angle of the wheelbase. It also allows for quicker turning and greater access to the top of the handrims.

Wheel camber is determined by pairs of interchangeable camber plugs which are available from your Sunrise Medical authorized dealer in 0°, 3°, and 6° angles.

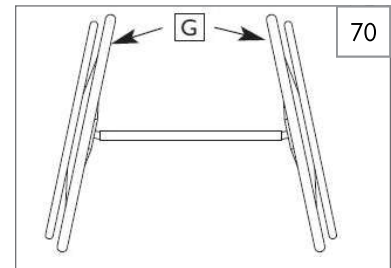

**3. Setting Toe-in toe-out to zero** 71 72 73 74

NOTE– A wheelchair equipped with 0° camber plugs cannot have a toe-in toe-out condition. This adjustment is only required when using 3° and 6° camber plugs.

Toe refers to how well the rear wheels of the chair are aligned relative to the ground. It affects how well the chair will roll. Drag or rolling resistance is optimally minimized when the wheel toe is set to zero.

**4. Setting the Toe to Zero** 71 72

Loosen the four cap screws (A) (two per side) that secure the camber tube clamp. Observe the ball in the level (C), and rotate the camber tube (B) until the ball is centered in the level. The toe is now set at zero.

Before tightening the screws (A), ensure that the camber tube is centered left-to-right relative to the wheelchair frame. The end of the camber tube should be flush with the outer most portion of the camber tube clamp. Torque fasteners (A) to 7 Nm [62 in-lbs].



**5. Setting the Toe to Zero– Alternative Method** 71 72 73 74

Place the entire wheelchair on a flat horizontal table or ground surface. Loosen the four cap screws (A) (two per side) that secure the camber tube clamp. Locate the flat surfaces on the front and rear of the camber plugs (D). Place an object that is known to have an accurate 90° corner (such as a carpenter's square, drafting triangle, etc.) down on the flat horizontal surface and up against the flat of the camber plug. Rotate the camber tube and plug assembly until the flat surface of the camber plug is parallel to the measuring tool.

Before tightening the screws (A), ensure that the camber tube is centered left-to-right relative to the wheelchair frame. The end of the camber tube should be flush with the outermost portion of the camber tube clamp. Torque the fasteners to 7 Nm [62 in-lbs].

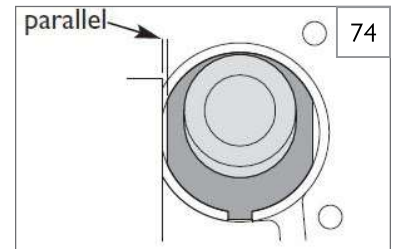
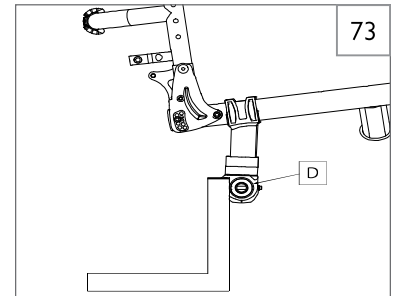
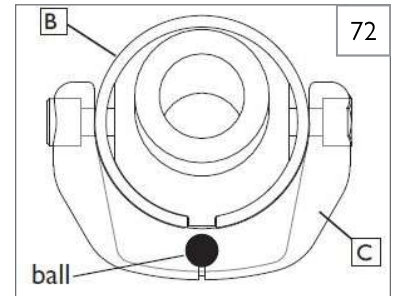
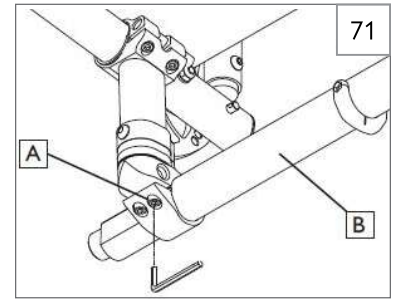

## IX. DEALER SERVICE AND ADJUSTMENT

### Q. REAR WHEEL SPACING 75 76

Rear wheel spacing is measured as the gap between the top of the rear wheels and the backcanes and is shown as dimension (X). Factory settings will be as narrow as possible depending on the options chosen.

When setting the rear wheel spacing only make adjustments to one side of the chair at a time. Loosening both sides will undo the toe setting.

To adjust the rear wheel spacing, the camber inserts (A) telescope in and out of the camber tube (B) with hard stops at the outer limit of travel. On the left side of the chair, loosen screws (C) (the ones closest to the camber tube). Slide the camber insert in or out to establish the required wheel spacing. Tighten screw to  7 Nm [62 in-lbs]. Repeat on the right side of the chair, matching the wheel spacing set on the left side.

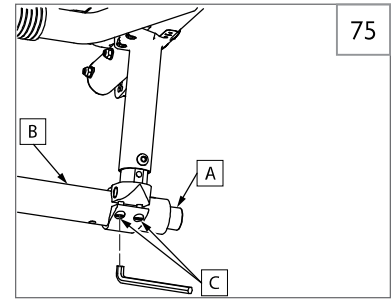

### R. CHECK-OUT

After the wheelchair is assembled and adjusted, it should roll smoothly and easily. All accessories should also perform smoothly. If you have any problems, follow these procedures:

1. Review the set-up and check-out sections and operating guide to ensure chair was properly prepared.
2. Review the troubleshooting chart at the beginning of this section.
3. If your problem persists, contact your Sunrise Medical authorized dealer. If you still have a problem after contacting your Sunrise Medical authorized dealer, contact Sunrise Medical customer service. See the Introduction Page for details on how to contact your Sunrise Medical authorized dealer or Sunrise Medical customer service.

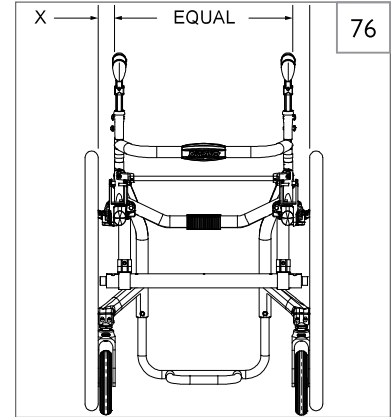

## X. SUNRISE LIMITED WARRANTY

### A. FOR LIFETIME

Frame and cross-brace (if applicable) warranty:

1. Although the anticipated useful service time of this wheelchair is five years, Sunrise Medical guarantees the frame and cross brace against defects in material and workmanship for life or for as long as the original purchaser owns the chair.
2. This warranty does not apply if:
  - a. The chair is subject to abuse.
  - b. The chair is not maintained as recommended in the owner's manual.
  - c. The chair is transferred to a different person from the original owner.

### B. FOR ONE (1) YEAR

We warrant all Sunrise-made parts and components of this wheelchair against defects in materials and workmanship for one year from the date of first consumer purchase.

Backrest Tension Adjustable (3DX, Ballistic, EXO, and EXO PRO):

Each Backrest Tension Adjustable is carefully inspected and tested to provide peak performance. Every Backrest Tension Adjustable is guaranteed to be free from defects in materials and workmanship for a period of twelve months from the date of purchase, provided normal use. Should a defect in materials or workmanship occur within twelve months from the original date of purchase, Sunrise Medical will, at its option, repair or replace it without charge. This warranty does not apply to puncture, tears or burns.

Claims and repairs should be processed through the nearest Sunrise Medical authorized dealer. Except for express warranties made herein, all other warranties including implied warranties of merchantability and warranties of fitness for particular purpose are excluded. There are not warranties which extend beyond the description of the face hereof. Remedies for breach of express warranties herein are limited to repair or replacement of the goods. In no event shall damages for breach of any warranty include any consequential damages or exceed the cost of non-conforming goods sold.

### C. LIMITATIONS

1. We do not warrant:
  - a. Tires and tubes, upholstery, pads, and push-handle grips.
  - b. Damage from neglect, accident, misuse, or from improper installation or repair.
  - c. Products modified without Sunrise Medical's express written consent.
  - d. Damage from exceeding the weight limit.
2. This warranty is VOID if the original chair serial number tag is removed or altered.
3. This warranty applies in the USA only. Check with your supplier to find out if international warranties apply.
4. This warranty is not transferable and only applies to the first consumer purchase of this wheelchair through a Sunrise Medical authorized dealer.

### D. WHAT WE WILL DO

Our sole liability is to repair or replace covered parts. This is the exclusive remedy for consequential damages.

### E. WHAT YOU MUST DO

1. Obtain from us, while this warranty is in effect, prior approval for return or repair of covered parts.
2. Return the wheelchair or part(s), freight pre-paid to the designated Sunrise Medical location.
3. Pay the cost of labor to repair, remove, or install parts.

### F. NOTICE TO CONSUMER

1. If allowed by law, this warranty is in place of any other warranty (written or oral, express or implied, including a warranty of merchantability, or fitness for a particular purpose).
2. This warranty gives you certain legal rights. You may also have other rights that vary from state to state.

### G. ADDITIONAL WARRANTY INFORMATION

For goods provided by Sunrise Medical Pty Ltd in Australia, our goods come with a guarantee by Sunrise that cannot be excluded under the Australian Consumer Law. You are entitled to a replacement or refund for a major failure and for compensation for any other reasonably foreseeable loss or damage. You are also entitled to have the goods repaired or replaced if the goods fail to be of acceptable quality and the failure does not amount to a major failure. The benefits to you given by this warranty are in addition to your other rights and remedies under a law in relation to the goods to which the warranty relates.

Record your serial number here for future reference:

(Serial Number label is located on the right side of frame cross brace next to the hand grip)

Sunrise Medical S.r.l.  
Via Riva, 20 – Montale  
29122 Piacenza  
Italia  
Tel.: +39 0523 573111  
www.SunriseMedical.it

Sunrise Medical AG  
Erlenauweg 17  
CH-3110 Münsingen  
Schweiz/Suisse/Svizzera  
Tel +41 (0)31 958 3838  
www.SunriseMedical.ch

Sunrise Medical AS  
Delitoppen 3  
1540 Vestby  
Norge  
Telefon: +47 66 96 38 00  
post@sunrisemedical.no  
www.SunriseMedical.no

Sunrise Medical AB  
Neogatan 5  
431 53 Mölndal  
Sweden  
Tel.: +46 (0)31 748 37 00  
post@sunrisemedical.se  
www.SunriseMedical.se

MEDICCO s.r.o.  
H – Park, Heršpická 1013/11d,  
639 00 Brno  
Czech Republic  
Tel.: (+420) 547 250 955  
Fax: (+420) 547 250 956  
www.medicco.cz  
info@medicco.cz  
Bezplatná linka 800 900 809

Sunrise Medical Aps  
Mårkærvej 5-9  
2630 Taastrup  
Denmark  
+45 70 22 43 49  
info@sunrisemedical.dk  
www.SunriseMedical.dk

Sunrise Medical Australia  
11 Daniel Street  
Wetherill Park NSW 2164  
Australia  
Ph: +61 2 9678 6600  
Email: enquiries@sunrisemedical.com.au  
www.SunriseMedical.com.au

Sunrise Medical (US) LLC  
North American Headquarters  
12002 Volunteer Blvd.  
Mount Juliet, TN 37122, USA  
(800) 333-4000  
(800) 300-7502  
www.SunriseMedical.com



© 2025 Sunrise Medical (US) LLC  
P/N 249817 Rev. D

Sunrise Medical GmbH  
Kahlbachring 2-4  
D-69254 Malsch  
Deutschland  
Tel.: +49 (0) 7253/980-0  
Fax: +49 (0) 7253/980-222  
www.SunriseMedical.de

Sunrise Medical Ltd.  
Thorns Road  
Brierley Hill  
West Midlands  
DY5 2LD  
England  
Phone: 0845 605 66 88  
Fax: 0845 605 66 89  
www.SunriseMedical.co.uk

Sunrise Medical S.L.  
Polígono Bakiola, 41  
48498 Arrankudiaga – Vizcaya  
España  
Tel.: +34 (0) 902142434  
Fax: +34 (0) 946481575  
www.SunriseMedical.es

Sunrise Medical Poland  
Sp. z o.o.  
ul. Elektronowa 6,  
94-103 Łódź  
Polska  
Telefon: + 48 42 275 83 38  
Fax: + 48 42 209 35 23  
E-mail: pl@sunrisemedical.de  
www.Sunrise-Medical.pl

Sunrise Medical B.V.  
Defensiedok 20  
3433 NE Nieuwegein  
The Netherlands  
T: +31 (0)30 – 60 82 100  
F: +31 (0)30 – 60 55 880  
E: info@sunrisemedical.nl  
www.SunriseMedical.nl

Sunrise Medical HCM B.V.  
Vossenbeemd 104  
5705 CL Helmond  
The Netherlands  
T: +31 (0)492 593 888  
E: customerservice@sunrisemedical.nl  
www.SunriseMedical.nl  
www.SunriseMedical.eu (International)

Sunrise Medical S.A.S  
ZAC de la Vrillonnerie  
17 Rue Mickaël Faraday  
37170 Chambray-Lès-Tours  
Tel : + 33 (0) 2 47 55 44 00  
Email: info@sunrisemedical.fr  
www.SunriseMedical.fr

Sunrise Medical Canada Inc.  
1000 Creditstone Rd., Unit #2  
Concord, ON, L4K 4P8  
Canada  
Phone: 1-800-263-3390  
Fax: 1-800-561-5834  
www.SunriseMedical.ca