



Q2 Lite

Quickie® Q2 Lite

Supplier: This manual must be given to the user of this wheelchair.

User: Before using this wheelchair read this entire manual and save for future reference.

Owner's Manual

Quickie® Q2 Lite

Distribuidor: Este manual debe ser entregado al pasajero de esta silla de ruedas.

Pasajero: Antes de usar esta silla de ruedas, lea este manual en su totalidad y guárdelo para futura referencia.

Manual de Instrucciones

Cada una de las sillas se envía con un manual de instrucciones en inglés. El manual en español o francés está disponible en formato PDF en nuestra página en Internet: www.SunriseMedical.com. Ingrese a la página del producto específico para descargar el manual, o comuníquese con el proveedor autorizado de Sunrise Medical.

Quickie® Q2 Lite

Fournisseur : Ce manuel doit être remis à l'utilisateur / utilisatrice de ce fauteuil roulant.

Utilisateur / Utilisatrice : Avant d'utiliser ce fauteuil roulant, lisez entièrement ce manuel et conservez le pour le consulter ultérieurement.

Mode d'emploi

Chaque fauteuil est livré avec un manuel d'instructions en anglais. Les versions en espagnol et en français sont à votre disposition en format PDF sur le site : www.SunriseMedical.com. Veuillez vous rendre à la page de votre produit pour télécharger le manuel dans la langue souhaitée, ou contactez un fournisseur agréé Sunrise Medical.



SUNRISE MEDICAL LISTENS

Thank you for choosing a Quickie wheelchair. We want to hear your questions or comments about this manual, the safety and reliability of your chair, and the service you receive from your Sunrise supplier. Please feel free to write or call us at the address and telephone number below:

Sunrise Medical (US) LLC
Customer Service Department
2842 Business Park Ave
Fresno, CA 93727 USA
(800) 333-4000



[www.sunrisemedical.com/
help-support/register-my-
wheelchair](http://www.sunrisemedical.com/help-support/register-my-wheelchair)

Be sure to register your wheelchair and let us know if you change your address. This will allow us to keep you up to date with information about safety, new products, and options to increase your use and enjoyment of this wheelchair.

You can also register your wheelchair at:
www.sunrisemedical.com/help-support/register-my-wheelchair.

FOR ANSWERS TO YOUR QUESTIONS

Your authorized supplier knows your wheelchair best, and can answer most of your questions about chair safety, use and maintenance. For future reference, fill in the following:

Supplier: _____

Address: _____

Telephone: _____

Serial #: _____ Date/Purchased: _____

ADDITIONAL INFORMATION YOU SHOULD KNOW

No component of this chair was made with Natural Rubber Latex.

**Disposal and recycling information:**

When this product reaches the end of its life, please take it to an approved collection or recycling point designated by your local or state government. This wheelchair is manufactured using a variety of materials. Your product should not be disposed of as ordinary household waste. You should dispose of your wheelchair properly, according to local laws and regulations. Most materials that are used in the construction of this product are fully recyclable. The separate collection and recycling of your product at the time of disposal will help conserve natural resources and ensure that it is disposed in a manner that protects the environment.

Ensure you are the legal owner of the product prior to arranging for the product disposal in accordance with the above recommendations.

I. INTRODUCTION	2	L. Rear Wheel Locks	13
II. TABLE OF CONTENTS	3	M.Modified Seat Systems	13
III. YOUR CHAIR AND ITS PARTS	4	N.Seat and Back Upholstery	13
IV. NOTICE - READ BEFORE USE	4	VIII. USE AND MAINTENANCE	14
V. GENERAL WARNINGS.....	5	A. Introduction	14
A. Weight Limits	5	B. Critical safety checks	14
B. Intended Use	5	C.Cleaning Tips.....	14
C.Attendants and Caregivers	5	D.Safety Checklist	14
D.Accessories	5	E. Troubleshooting Chart.....	14
E. Know Your Chair	5	F. To Mount and Remove Rear Wheels.....	15
F. Reduce The Risk of an Accident	5	G.Wheel Locks	15
G.Safety Checklist	5	H.Anti-tips tubes.....	15
H.Changes & Adjustments	6	I. Armrests.....	16
I. Environmental Conditions	6	J. Padded Swing-away Armrests	16
J. Terrain	6	K. Footrests, Legrests & Footplates	17
K. Street Use	6	L. Z-Finity™ Footrest System	17
L. Motor Vehicle Safety	6	M.Back Posts and integral Push handles	18
M.When You Need Help	7	N.Seating and Seat Sling Upholstery	18
N.Choking Hazard	7	O Side Guards	19
O.Pinch Point	7	P. Folding and Unfolding.....	19
VI. WARNINGS: FALLS AND TIP-OVERS.....	8	Q.Storage Tips.....	19
A. Center of Balance	8	R. Inspect	19
B. Dressing or Changing Clothes	8	IX. DEALER SERVICE AND ADJUSTMENT	20
C.Obstacles	8	A. Dealer Service Introduction.....	20
D.Front Caster Lift	8	B. Critical Maintenance Tips.....	20
E. Reaching or Leaning	8	C.Cleaning.....	20
F. Moving Backward	8	D.Rear Axles &Axle Plates.....	20
G.Escalators	9	E. Rear Wheel Axle Nut Adjustment.....	21
H.Ramps, Slopes & Sidehills	9	F. Squaring the anti-tip tubes	21
I. Transfers	10	G.Wheel Locks.....	22
J. Curbs & Single Steps.....	10	H.Caster Forks	22
K. Climbing a Curb or Single step	11	I. Casters	22
L. Descending a Curb or Single step	11	J. Anti-tip receivers	23
M.Stairs	11	K.Armrest Receiver Attachment.....	24
N.Climbing Stairs	11	L. Padded Swing-Away Armrests	24
O.Descending Stairs	11	M.Swing-in, Swing-out Hangers and Footrests	25
VII. WARNINGS: COMPONENTS AND OPTIONS.....	12	N. Angle Adjustable Footplates.....	25
A. Anti-tip Tubes.....	12	O.Platform and Auto-fold Footrests	25
B. Armrests	12	P. Z-Finity™ Footrest System	26
C. Caster Pin Locks	12	Q. Backrest.....	27
D. Cushions and Seat Slings	12	R. Angle adjustable Backrest.....	27
E. Fasteners.....	12	S. Backrest Tension Adjustable	28
F. Footrests.....	12	T Removing Seat Rails	29
G.Pneumatic Tires	12	U. Seat Saddle Adjustment.....	29
H.Positioning Belts Option	13	V. Sideguard Hardware	29
I. Push handles Option.....	13	W. Limb Support.....	29
J. Quick-Release Axles	13	X. SUNRISE LIMITED WARRANTY.....	31
K. Rear Wheels.....	13		

QUICKIE Q2 LITE- FIXED FRONT

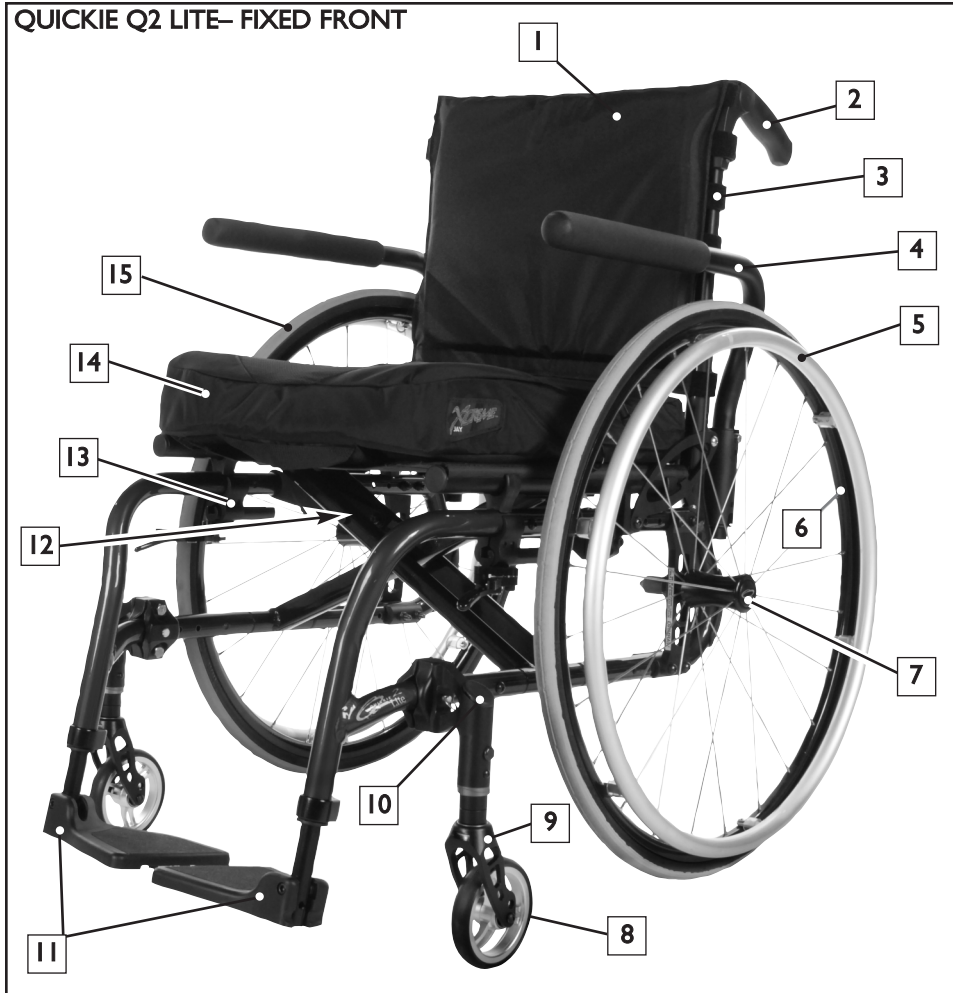

1. Backrest
2. Integral Push handle
3. Backrest Tube
4. Padded Swing away Armrest
5. Aluminum Handrim
6. Aluminum Wheel Rim
7. Rear Hub/ Quick-Release Axle
8. Caster Wheel
9. Caster Fork
10. Caster Housing Cap
11. Height adjustable Footrests
12. X-Hinge
13. Wheel Lock
14. Cushion/Seat Sling
15. Pneumatic Tire

NOTE-

All features may not be available with some chair setups or in conjunction with another chair feature. Please consult your authorized supplier for more information.

IV. NOTICE- READ BEFORE USE

A. CHOOSE THE RIGHT CHAIR & SAFETY OPTIONS

Sunrise provides a choice of many wheelchair styles to meet your needs. This product is intended for single person use only. Final selection of the type of wheelchair, options and adjustments rests solely with you and your health care professional. Choosing the best chair for your unique mobility needs, will depend on such things as:

1. Your disability, strength, balance and coordination.
2. The types of hazards you must overcome in daily use (where you live and work, and other places you are likely to use your chair).
3. The need for options that will improve your positioning, safety and comfort (such as anti-tip tubes, positioning belts, or special seating systems).

B. REVIEW THIS MANUAL OFTEN

Before using this chair you, and each person who may assist you, should read this entire manual and make sure to follow all instructions. Review the warnings often, until they are second nature to you.

C. WARNINGS 

The word "WARNING" refers to a hazard or unsafe practice that may cause severe injury or death to you or to other persons. The "Warnings" are in three main sections, as follows:

1. V — GENERAL WARNINGS

Here you will find a safety checklist and a summary of risks you need to be aware of before you ride this chair.

2. VI- SAFETY WARNINGS: FALLS & TIP-OVERS

Here you will learn about practices for the safe use of your chair, and how to avoid a fall or tip-over while you perform daily activities in your chair.

3. VII — WARNINGS — COMPONENTS & OPTIONS

Here you will learn about the components of your chair and options you can select for safety. Consult your authorized supplier and your health care advisor to help you choose the best set-up and options for safe use.

NOTE- Where they apply, you will also find "Warnings" in other sections of this manual. Heed all warnings in these sections. If you fail to do so a fall, tip-over or loss of control may occur and cause severe injury to the rider or others.

A. WEIGHT LIMITS**⚠ WARNING**

NEVER exceed the weight limit specified by Sunrise Medical. The weight capacity provided by your manufacturer is for the combined weight of a rider and items carried using on-board storage. If you do exceed the weight limit, damage to your chair, a fall, tip-over or loss of control may occur and cause severe injury to the rider or others.

Weight Capacity

Quickie2 Lite - 265l bs/(120 kg).

Option Specific Weight Capacities:

Z-Finity™ Footrest – 165 lbs / (75 kg)

B. INTENDED USE

The Quickie 2 Series of wheelchair's intended use is to provide mobility to persons limited to a sitting position.

⚠ WARNING

DO NOT use this device for purposes other than what is intended by the manufacturer

1. The wheelchair is not designed for weight training and is unsafe for use as a seat while weight training. Weight training from the wheelchair substantially changes the stability of the chair and may cause tipping.
2. DO NOT stand on the frame of the wheelchair.
3. NEVER allow someone to stand on your chair or use it as a step ladder.
4. This chair is designed for a single rider only.
5. Unauthorized modifications and use of parts or accessories not supplied or approved by Sunrise Medical may change the chair structure. This will void the warranty and may cause a safety hazard. If the warning is ignored, damage to your chair, and the potential severe injury of the person using the chair for unintended purposes can occur.

C. ATTENDANTS AND CAREGIVERS**⚠ WARNING**

Before you assist a rider, be sure to read all warnings contained in this manual, and follow all instructions that apply. Be aware that after consulting a healthcare advisor, you will need to learn safe and proven body mechanics to use and create assistive methods best suited to your abilities.

D. ACCESSORIES**⚠ WARNING**

Unauthorized modifications or use of parts, or accessories not supplied or approved by Sunrise Medical may change the chair structure. This will void the warranty and may cause a safety hazard.

Some problems that may occur, but are not limited to:

1. Incorrect Wheels and/or tires that put the rider at risk of a fall or tip-over.
2. Adding a component to the frame, changing the structural integrity of the chair.
3. Any modification or disassembly can potentially create an unsafe situation where rider and/or attendant are put at risk.

E. KNOW YOUR CHAIR**⚠ WARNING**

Every wheelchair is different. Take the time to learn the feel of this chair before you begin riding. Start slowly, with easy, smooth strokes. If you are used to a different chair, you may use too much force and tip over. If you use too much force, damage to your chair, a fall, tip-over or loss of control may occur and cause severe injury to the rider or others.

F. REDUCE THE RISK OF AN ACCIDENT**⚠ WARNING**

1. BEFORE you begin riding, you should be trained in the safe use of this chair by your health care advisor.
2. Practice bending, reaching and transfers until you know the limit of your ability. Have someone help you until you know what can cause a fall or tip-over and how to avoid doing so.
3. Be aware that you must develop your own methods for safe use best suited to your level of function and ability.
4. NEVER try a new maneuver on your own. Ask the advice of your health care provider to lower the risk of a fall or tip over.
5. Get to know the areas where you plan to use your chair. Look for hazards and learn how to avoid them.

G. SAFETY CHECKLIST**⚠ WARNING**

Before Each Use Of Your Chair:

1. Make sure the chair rolls easily and that all parts work smoothly. Check for noise, vibration, or a change in ease of use. (This may indicate low tire pressure, loose fasteners, or damage to your chair).
2. Immediately repair any problem. Your authorized supplier can help you find and correct the problem.
3. Check to see that both quick-release rear axles are locked. When locked, the axle button will "pop out" fully. If not locked, the wheel may come off and cause you to fall.
4. If your chair has anti-tip tubes, lock them in place.

H. CHANGES & ADJUSTMENTS

⚠ WARNING

1. If you modify or adjust this chair, it may increase the risk of a tip-over **UNLESS** you make other adjustments as well.
2. Consult your authorized supplier **BEFORE** you modify or adjust your chair.
3. We recommend that you use anti-tip tubes until you adapt to the change, and are sure you are not at risk to tip over.
4. Unauthorized modifications by the end-user, dealer or any other individual, including the use of parts not supplied or approved by Sunrise may change the chair structure. This will void the warranty and may cause a safety hazard.

If you fail to heed these warnings damage to your chair, a fall, tip-over or loss of control may occur and cause severe injury to the rider or others.

I. ENVIRONMENTAL CONDITIONS

⚠ WARNING



1. Use extra care if you must ride your chair on a wet or slick surface. If you are in doubt, ask for help.
2. Contact with water or excess moisture may cause your chair to rust or corrode. Avoid all extreme weather situations if possible.
 - a. Do not use your chair in a shower, pool or other body of water. The chair tubing and parts are not water-tight and may rust or corrode from the inside.
 - b. Avoid excess moisture (for example, do not leave your chair in a damp bathroom while taking a shower).
 - c. Dry your chair as soon as you can if it gets wet, or if you use water to clean it.
 - d. Avoid contact with salt or salty conditions as this may cause damage to the chair.

If you fail to heed these warnings damage to your chair, a fall, tip-over or loss of control may occur and cause severe injury to the rider or others.

J. TERRAIN

⚠ WARNING

1. Based on ANSI/RESNA testing, Sunrise Medical recommends the use of a caster wheel with a minimum diameter of 5", if the wheelchair will be overcoming obstacles up to 1/2" on a regular basis.
2. Your chair is designed for use on firm, even surfaces such as concrete, asphalt, indoor flooring, and carpets.
3. Do not operate your chair in sand, loose soil, or over rocky terrain.
4. If you use your chair on terrain that is rougher than described above there is a danger that screws and bolts will loosen prematurely, and that damage to wheels or axles could put the rider at risk of a fall, tip-over, or loss of control.

If you fail to heed these warnings damage to your chair, a fall, tip-over or loss of control may occur and cause severe injury to the rider or others.

K. STREET USE

⚠ WARNING

1. This product is not intended for street use.
2. Avoid streets whenever possible.
3. Obey and follow all legal pedestrian pathways, and laws that apply to pedestrians.
4. Be alert to the danger of motor vehicles in parking lots, or if you must cross a road.

If you fail to heed this warning, damage to your chair, and a possible collision may occur and cause severe injury to the rider or others.

L. MOTOR VEHICLE SAFETY 1 2

If possible and feasible, the rider should transfer to the Original Equipment Manufacturer vehicle seat and use the OEM vehicle restraint.

Sunrise Medical does provide a WC-19 Wheelchair Tie-Down and Occupant Restraint System, otherwise called a Transit Option. To Identify whether your wheelchair has been manufactured with the Transit Option installed, look for four points of securement. Two front hooks (A), and two rear hooks (B). These points are recognized by the securement point decal which can be found on or near the securement points. (C) is a non-removable fastener.

This component must remain securely attached to the frame in order to maintain Transit Safety

If your wheelchair has the Transit Option, please review the Transit Securement supplement that was provided with the wheelchair for additional information and instructions. You can request a copy from your authorized supplier, or call Sunrise Medical at 1-800-333-4000 if you don't have it.

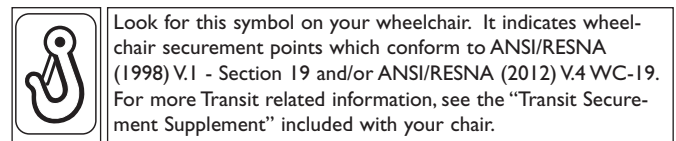
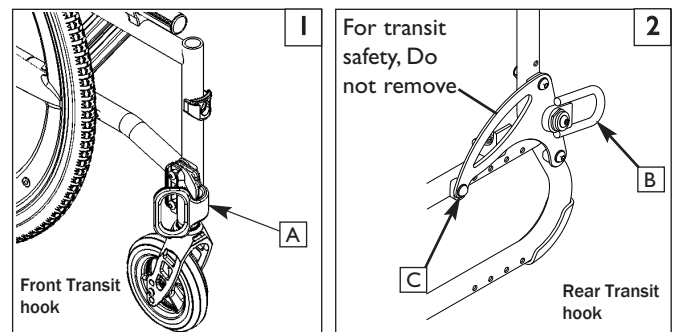

⚠ WARNING

If your chair is **NOT** equipped with the Transit Option:

1. NEVER let anyone sit in this chair while in a moving vehicle.
 - a. ALWAYS move the rider to an approved vehicle seat.
 - b. ALWAYS secure the rider with proper motor vehicle restraints.
2. In an accident or sudden stop the rider may be thrown from the chair. Wheelchair seat belts will not prevent this, and further injury may result from the belts or straps.
3. NEVER transport this chair in the front seat of a vehicle. It may shift and interfere with the driver.
4. ALWAYS secure this chair so that it cannot roll or shift.
5. Do not use any chair that has been involved in a motor vehicle accident. The frame and/or components may have been changed due to the accident. Such items could be, but are not limited to: bent, loosened, and/or broken components that were subjected to an impact.

Failure to heed these warnings puts you and others who may assist you at a high risk of injury.

M. WHEN YOU NEED HELP

WARNING

For The Rider: Make sure that each person who helps you reads and follows all warnings and instructions that apply.

For Attendants:

1. Work with the rider's doctor, nurse or therapist to learn safe methods best suited to your abilities and those of the rider.
2. Tell the rider what you plan to do, and explain what you expect the rider to do. This will put the rider at ease and reduce the risk of an accident.
3. Make sure the chair has push handles. They provide secure points for you to hold the rear of the chair to prevent a fall or tip-over. Check to make sure push handle grips will not rotate or slip off.
4. To prevent injury to your back, use good posture and proper body mechanics. When you lift or support the rider or tilt the chair, bend your knees slightly and keep your back as upright and straight as you can.
5. Remind the rider to lean back when you tilt the chair backward.
6. When you descend a curb or single step, slowly lower the chair in one easy movement. Do not let the chair drop the last few inches to the ground. This may damage the chair or injure the rider.
7. To avoid tripping, unlock and rotate anti-tip tubes up, out of the way.
8. Whenever you aren't attending the wheelchair, ALWAYS use the wheel-lock to secure the rear wheels, and lock the anti-tip tubes in place.

If you fail to ask for help when in doubt, you run a high risk of a fall, tip-over or loss of control that may occur and cause severe injury to the rider or others.

N. CHOKING HAZARD

WARNING

NOTE- Your chair consists of many small parts that could present a choking hazard to young children. Take care to put parts out of reach when doing any work on the chair.

O. PINCH POINT

WARNING

NOTE- Your wheelchair has many moving parts that can create pinch points and possible finger traps. Be aware when making any adjustments, when folding and unfolding, when moving, and any other situation that could cause a pinch point situation.

A. CENTER OF BALANCE**⚠ WARNING**

The point where this chair will tip forward, back or to the side depends on its center of balance and stability. How your chair is set up, the options you select and the changes you make may affect the risk of a fall or tip-over.

1. The Most Important Adjustment Is:
The position of the rear wheels. The more you move the rear wheels forward, the more likely your chair will tip over backward.
2. The Center Of Balance Is Also Affected By:
 - a. A change in the set-up of your chair, including:
 - The distance between the rear wheels.
 - The amount of rear wheel camber.
 - The seat height and seat angle.
 - Backrest angle.
 - b. A change in your body position, posture or weight distribution.
 - c. Riding your chair on a ramp or slope.
 - d. A back pack or other options and the amount of added weight.
3. To Reduce The Risk Of An Accident:
 - a. Consult your doctor, nurse or therapist to find out what axle and caster position is best for you.
 - b. Consult your authorized supplier BEFORE you modify or adjust this chair. Be aware that you may need to make other changes to correct the center of balance.
 - c. Have someone help you until you know the balance points of your chair and how to avoid a tip-over.
 - d. Use anti-tip tubes.

If you fail to heed these warnings, you are at a high risk of a fall, tip-over or loss of control that could cause severe injury to the rider or others.

B. DRESSING OR CHANGING CLOTHES**⚠ WARNING**

Your weight may shift if you dress or change clothes while seated in this chair.

- To reduce the risk of a fall or tip-over:
1. Rotate the front casters until they are as far forward as possible. This makes the chair more stable.
 2. Lock anti-tip tubes in place. (If your chair does not have anti-tip tubes, back it up against a wall and lock both rear wheels).

If you fail to heed this warning, damage to your chair, a fall, tip-over or loss of control may occur and cause severe injury to the rider or others.

C. OBSTACLES**⚠ WARNING**

Riding over curbs or obstacles can cause tipping and serious bodily harm. If you have any doubt that you can safely cross any curb or obstacle, ALWAYS ASK FOR HELP. Be aware of your riding skills and personal limitations.

Develop new skills only with the help of a companion.

- To avoid the risk of traversing obstacles:
1. Keep a lookout for danger – scan the area well ahead of your chair as you ride.
 2. Make sure the floor areas where you live and work are level and free of obstructions.
 3. Remove or cover threshold strips between rooms.
 4. Install a ramp at entry or exit doors. Make sure there is not a drop off at the bottom of the ramp.
 5. To Help Correct Your Center Of Balance:
 - a. Lean your upper body FORWARD slightly as you go UP over an obstacle.
 - b. Press your upper body BACKWARD as you go DOWN from a higher to a lower level.
 6. If your chair has anti-tip tubes, do not go over an obstacle without help.

7. Keep both of your hands on the handrims as you go over an obstacle.
8. Never push or pull on an object (such as furniture or a doorjamb) to propel your chair.

If you fail to heed these warnings damage to your chair, a fall, tip-over or loss of control may occur and cause severe injury to the rider or others.

D. FRONT CASTER LIFT**⚠ WARNING**

Front caster lift can occur when the front wheels, ordinarily in contact with the ground, are either intentionally, or unintentionally caused to lift from the ground while the rear wheels remain in contact. Pitch control (partial or full) should NEVER be attempted without consulting your healthcare advisor and making sure that anti-tips are installed.

If you fail to heed this warning, you are at a high risk of damage to your chair, a fall, tip-over or loss of control that may occur and cause severe injury to the rider or others.

E. REACHING OR LEANING**⚠ WARNING**

If you reach or lean it will affect the center of balance of your chair. This may cause you to fall or tip over. When in doubt, ask for help or use a device to extend your reach.

1. NEVER reach or lean if you must shift your weight sideways or rise up off the seat.
2. NEVER reach or lean if you must move forward in your seat to do so. Always keep your buttocks in contact with the backrest.
3. NEVER reach with both hands (you may not be able to catch yourself to prevent a fall if the chair tips).
4. NEVER reach or lean to the rear unless your chair has anti-tip tubes locked in place.
5. DO NOT reach or lean over the top of the seat back. This may damage one or both backrest tubes and cause you to fall.
6. If You Must Reach Or Lean:
 - a. Do not lock the rear wheels. This creates a tip point and makes a fall or tip-over more likely.
 - b. Do not put pressure on the footrests.
 - c. Move your chair as close as you can to the object you wish to reach.
 - d. Do not try to pick up an object from the floor by reaching down between your knees. You are less likely to tip if you reach to the side of your chair.
 - e. Rotate the front casters until they are as far forward as possible. This makes the chair more stable.
 - f. Firmly grasp a rear wheel or an armrest with one hand. This will help to prevent a fall if the chair tips.

If you fail to heed these warnings damage to your chair, a fall, tip-over or loss of control may occur and cause severe injury to the rider or others.

F. MOVING BACKWARD**⚠ WARNING**

Use extra care when you move your chair backward. Your chair is most stable when you propel yourself forward. You may lose control or tip over if one of the rear wheels hits an object and stops rolling.

1. Propel your chair slowly and smoothly.
2. If your chair has anti-tip tubes, make sure to lock them in place.
3. Stop often and check to be sure your path is clear.

If you fail to heed this warning, you are at a high risk of damage to your chair, a fall, tip-over or loss of control that may occur and cause severe injury to the rider or others.

G. ESCALATORS

⚠ WARNING

NEVER use this chair on an escalator, even with an attendant. If you do, a fall or tip-over is likely.

Failure to heed these warnings puts you and others who may assist you at a high risk of injury.

H. RAMPS, SLOPES & SIDEHILLS 3 4 5 6**⚠ WARNING**

Whenever possible, avoid riding on a slope, which includes a ramp or side-hill. This will change the center of balance of your chair. Your chair is less stable and more difficult to maneuver when it is at an angle. When moving up a hill, anti-tip tubes may not prevent a fall or tip-over.

1. **DO NOT** use your chair on a slope steeper than 6°.
2. **ALWAYS** go as straight up and as straight down as you can. (Do not "cut the corner" on a slope or ramp.)
3. **DO NOT** turn or change direction on a slope.
4. When you have to use a ramp, always stay in the **CENTER** of the ramp. Make sure ramp is wide enough that you have no risk of going off the edge.
5. **DO NOT** stop on a steep slope. If you stop, you may lose control of your chair.
6. **NEVER** use rear wheel locks to try to slow or stop your chair. This is likely to cause your chair to veer out of control.
7. **ALWAYS** be aware of:
 - a. Wet or slippery surfaces.
 - b. A change in grade on a slope (or a lip, bump or depression). These may cause a fall or tip-over.
 - c. A drop-off at the bottom of a slope or ramp. A drop-off as small as 3/4 inch can stop a front caster and cause the chair to tip forward.
8. To Reduce The Risk Of A Fall Or Tip-Over:
 - a. Lean or press your body **UPHILL**. This will help adjust for the change in the center of balance caused by the slope or sidehill.
 - b. Keep pressure on the handrims to control your speed on a down slope. If you go too fast you may lose control.
 - c. **ASK FOR HELP** any time you are in doubt.
9. Ramps At Home & Work– For your safety, ramps at home and work must meet all legal requirements for your area:
 - a. **AVOID A DROP-OFF**
Make sure there is a section at the top or bottom to smooth out the transition.
 - b. **ALWAYS** stay in the center of the ramp and control your speed.

If you fail to heed these warnings damage to your chair, a fall, tip-over or loss of control may occur and can possibly cause severe injury to the rider or others.

For Attendants:

Follow these steps to help the rider go up or down a ramp:

1. Stay behind the chair.
2. Firmly grasp the handles.
3. For going up or down a ramp, the chair should always be facing forward.

If you fail to heed these warnings damage to your chair, a fall, tip-over or loss of control may occur and cause severe injury to the rider or others

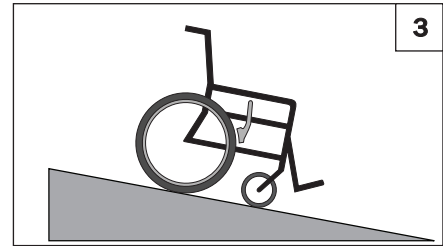

IF you need to go down a hill:

- a. The downslope should be less than 6°.
- b. **GO SLOW control your speed.**
- c. **ALWAYS** Go straight down.
- d. **NEVER** turn on a hill.
- e. **ALWAYS** lean backward.

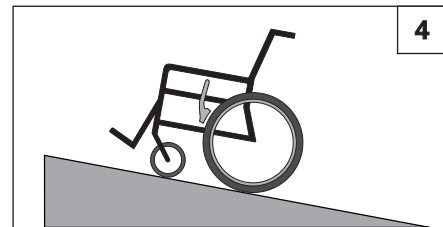

IF you need to go up a hill:

- a. The upslope should be less than 6°.
- b. **ALWAYS** Go straight up.
- c. **DON'T STOP.**
- d. **NEVER** turn on a hill.
- e. **ALWAYS** lean forward.

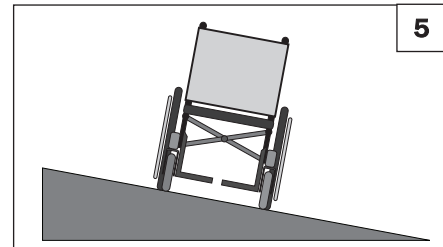

IF you need to traverse a Side-hill:

- a. The side-hill must be Less than 6° or you are at risk of a tip over.
- b. **DON'T STOP.**
- c. **NEVER** turn on a hill.

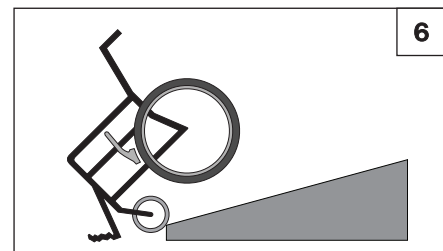

If you need to traverse a Ramp:

- a. Go Slowly.
- b. Watch out for Drop-offs.
- c. **ALWAYS** go straight up or straight down.
- d. Stay centered on the ramp.

I. TRANSFERS 7 8

⚠ WARNING

It is dangerous to transfer on your own. It requires good balance and agility. Be aware that there is a point during every transfer when the wheelchair seat is not below you. To avoid a fall:

1. Work with your health care advisor to learn safe methods for transfers.
 - a. Learn how to position your body and how to support yourself during a transfer.
 - b. Have someone help you until you learn safe transfer methods.
2. Lock the rear wheels before you transfer.
3. Be aware that the chair can still slide and/or tip. The wheel lock keeps the rear wheels from rolling while you are performing the transfer.
4. Make sure that the pneumatic tires are properly inflated. Low tire pressure may allow the rear wheel locks to slip. (see table in Section G "Pneumatic Tires").
5. Move your chair as close as you can to the seat you are transferring to. If possible, use a transfer board.
6. Rotate the front casters until they are as far forward as possible.
7. If you can, remove the footrests, or swing them out of the way.
 - a. Make sure your feet do not catch in the space between the footrests.
 - b. Avoid putting weight on the footrests as this may cause the chair to tip.
8. Make sure armrests are removed, or out of the way and do not interfere with the transfer.
9. Transfer as far back onto the seat surface as you can. This will reduce the risk that the chair will tip or move away from you.

Optimum Transfer position



Before transferring:

1. Flip-back or remove the armrests.
2. Swing-away or remove the footrests.
3. Make sure the wheel lock is set.

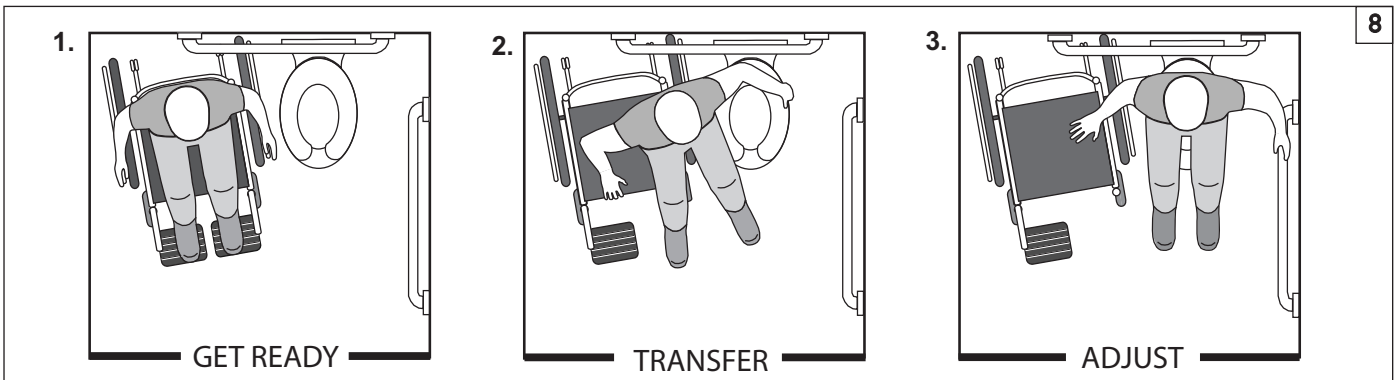

J. CURBS & SINGLE STEPS 9

⚠ WARNING

Before riding over curbs, and negotiating even a single step, ALWAYS ask for assistance first. Curbs and steps can cause tipping and serious bodily harm. When in doubt as to your ability to avoid, or traverse any obstacle, always ask for help. Be aware of your riding skills and personal limitations. Develop new skills only with the help of a companion.

For Attendant: Each person who assists the rider with curbs and steps should read and follow all instructions and warnings pertaining to attendants, and caregivers.

1. Do not try to climb a high curb or step (more than 4 inches high) UNLESS you have help. Doing so may cause your chair to exceed its balance point and tip over.
2. Go straight up and straight down a curb or step. If you climb or descend at an angle, a fall or tip-over is likely.
3. Be aware that the impact of dropping down from a curb or step can damage your chair or loosen fasteners.

If you fail to heed these warnings damage to your chair, a fall, tip-over or loss of control may occur and can possibly cause severe injury to the rider or others.

K. CLIMBING A CURB OR SINGLE STEP 9**⚠ WARNING**

For Attendant: Follow these steps to help the rider climb a curb or single step going FORWARD:

1. Stay behind the chair.
2. Continue backward until the rear wheels contact the face of the curb or step. Lift and roll the rear wheels to the top of the curb.
3. Pull the chair backwards until the caster wheels have cleared the edge of the curb and return the chair to its rolling position.

If you fail to heed these warnings damage to your chair, a fall, tip-over or loss of control may occur and cause severe injury to the rider or others.

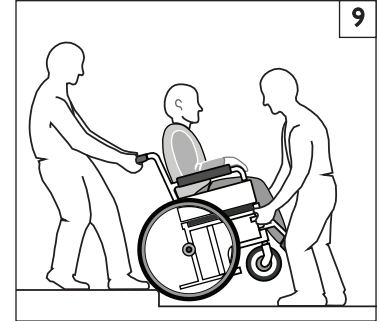
**L. DESCENDING A CURB OR SINGLE STEP** 9**⚠ WARNING**

For Attendant: Follow these steps to help a rider descend a curb or single step going BACKWARD:

1. Stay at the rear of the chair.
2. Several feet before you reach the edge of the curb or step, tip the chair slightly and pull it backward.
3. When the chair is at its balance point, carefully step forward until the rear wheels reach the edge of the curb or step. Then allow the rear wheels to slowly roll down onto the lower level.
4. Push the chair forward until you are standing on the lower level.
5. When the rear wheels are safely on the lower level, tilt the chair back to its balance point.

If you fail to heed these warnings damage to your chair, a fall, tip-over or loss of control may occur and cause severe injury to the rider or others.

M. STAIRS 10**⚠ WARNING**

1. NEVER use this chair on stairs UNLESS you have someone to help you. Doing so is likely to cause a fall or tip-over.
2. Negotiating stairs with a wheelchair always requires at least 2 attendants for safety.

If you fail to heed these warnings damage to your chair, a fall, tip-over or loss of control may occur and cause severe injury to the rider or others.

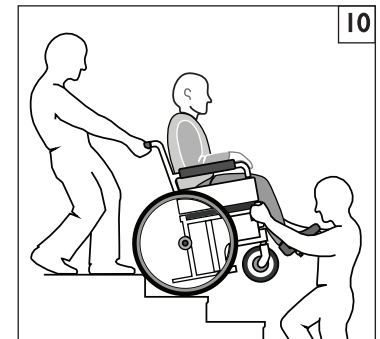
**N. CLIMBING STAIRS** 10**⚠ WARNING**

1. Use at least two attendants to move a chair and rider up stairs.
2. Move the chair and rider BACKWARD up the stairs.
3. The person at the rear is in control. He or she tilts the chair back to its balance point.
4. A second attendant at the front firmly grasps a non-detachable part of the front frame and lifts the chair up and over one stair at a time.
5. The attendants move to the next stair up. Repeat for each stair, until you reach the landing.

If you fail to heed these warnings damage to your chair, a fall, tip-over or loss of control may occur and cause severe injury to the rider or others.

O. DESCENDING STAIRS 10**⚠ WARNING**

1. Use at least two attendants to move a chair and rider down stairs.
2. Move the chair and rider FORWARD down the stairs.
3. The person at the rear is in control. He or she tilts the chair to the balance point of the rear wheels and rolls it to the edge of the top step.
4. A second attendant stands on the third step from the top and grasps the chair frame. He or she lowers the chair one step at a time by letting the rear wheels roll over the stair edge.
5. The attendants move to the next stair down. Repeat for each stair, until you reach the landing.

If you fail to heed these warnings damage to your chair, a fall, tip-over or loss of control may occur and cause severe injury to the rider or others.

A. ANTI-TIP TUBES



Anti-tip tubes can help keep your chair from tipping over backward in normal conditions.

1. Sunrise recommends the use of anti-tip tubes:
2. When locked in place (in the “down” position) anti-tip tubes should be BETWEEN 1-1/2 to 2 inches off the ground.
 - a. If set **higher** than 2 inches, they may not prevent a tip-over.
 - b. If set **lower** than 1-1/2 inches, they may “hang up” on obstacles and cause a fall or tip over.
3. If you have to climb or descend a curb, or overcome an obstacle it may be necessary to have an attendant make sure the anti-tip tubes are rotated up, and out of the way, so that the chair and rider do not get stuck and/or become unstable.

If you fail to heed these warnings damage to your chair, a fall, tip-over or loss of control may occur and cause severe injury to the rider or others.

B. ARMRESTS



Armrests detach and will not bear the weight of this chair.

1. NEVER lift this chair by its armrests. They may come loose or break.
2. Lift this chair only by non-detachable parts of the main frame.

If you fail to heed these warnings damage to your chair, a fall, tip-over or loss of control may occur and cause severe injury to the rider or others.

C. CASTER PIN LOCKS



Always use both pin locks when transferring in and out of the chair.

Caster pin locks only keep the front caster wheels from changing direction, they do not lock-out the front wheels from rotation. To prevent the wheelchair from rolling, you must engage the rear wheel locks.

If you propel your wheelchair with the caster pin locks engaged, the chair will be prevented from turning.

If you fail to heed these warnings damage to your chair, a fall, tip-over or loss of control may occur and cause severe injury to the rider or others.

D. CUSHIONS & SLING SEATS



1. Quickie sling seats and standard foam cushions are not designed for the relief of pressure.
2. If you suffer from pressure sores or if you are at risk that they will occur, you may need a special seat system or a device to control your posture. Consult your doctor, nurse or therapist to find out if you need such a device for your well-being.
3. Seat slings are not intended to be used as a direct seating surface. A cushion or other seating surface should be placed on the sling before use.

If you fail to heed these warnings damage to your chair, a fall, tip-over or loss of control may occur and cause severe injury to the rider or others.

E. FASTENERS



Many of the screws, bolts and nuts on this chair are special high-strength fasteners. Use of improper fasteners may cause your chair to fail.

1. ONLY use fasteners provided by an authorized supplier (or ones of the same type and strength, as indicated by the markings on the heads).
2. Over- or under-tightened fasteners may fail or cause damage to chair parts.
3. If bolts or screws become loose, tighten them as soon as you can.

NOTE- For safety and optimum performance it is best to not reuse fasteners.

If you fail to heed these warnings damage to your chair, a fall, tip-over or loss of control may occur and cause severe injury to the rider or others.

F. FOOTRESTS



1. At the lowest point, footrests should be AT LEAST 2 inches off the ground. If set too LOW, they may “hang up” on obstacles you can expect to find in normal use. This may cause the chair to stop suddenly and tip forward.
2. To Avoid A Trip Or Fall When You Transfer:
 - a. Make sure your feet do not “hang up” or get caught in the space between the footrests.
 - b. Avoid putting weight on the footrests, as the chair may tip forward.
 - c. Footrests should be swung out of the way or removed whenever entering or exiting the wheelchair.
3. NEVER lift this chair by the footrests. Footrests detach and will not bear the weight of this chair. Lift this chair only by non-detachable parts of the main frame.
4. NEVER use the footrests of your chair to open doors, this may cause them to fail prematurely and create an unsafe situation.

If you fail to heed these warnings damage to your chair, a fall, tip-over or loss of control may occur and cause severe injury to the rider or others.

G. PNEUMATIC TIRES



Proper inflation extends the life of your tires and makes your chair easier to use.

1. Do not use this chair if any of the tires are under- or over-inflated. Check weekly for proper inflation level, as listed on the tire sidewall.
2. Low pressure in a rear tire may cause the wheel lock on that side to slip and allow the wheel to turn when you do not expect it.
3. Low pressure in any of the tires may cause the chair to veer to one side and result in a loss of control.
4. Over-inflated tires may burst.

If you fail to heed these warnings damage to your chair, a fall, tip-over or loss of control may occur and cause severe injury to the rider or others.

Tires	Quickie 2 Lite	Recommended Pressure or Pressure Range	
		kPa	PSI
Pneumatic - 20"	x	448	65
Pneumatic - 22"	x	448	65
Pneumatic - 24"	x	517	75
Pneumatic - 26"	x	448	65
High Pressure Clincher (22")	x	690	100
High Pressure Clincher (24")	x	758	110
High Pressure Clincher (25")	x	758	110
High Pressure Clincher (26")	x	758	110
Knobby V-Track (24")	x	448	65
Mountain (24")	x	448	65
Schwalbe Marathon (24")	x	586 - 1000	85-145
Schwalbe Marathon (25")	x	586 - 1000	85-145
Schwalbe Marathon (26")	x	586 - 1000	85-145

H. POSITIONING BELTS (Optional)**⚠ WARNING**

The positioning belt is predominately used to support your posture. It can also be used to limit slipping and/or sliding that you might experience when the chair is in motion. The positioning belt is not a transit rated safety belt and should not be used in the place of a seat belt while being transported in a motor vehicle. Improper use of positioning belts may cause severe injury or death. If you use a positioning belt, be sure to follow the recommendations in this section:

1. Make sure the rider does not slide down in the wheelchair seat. If this occurs, the rider may suffer chest compression or suffocate due to pressure from the belts.
2. The belts must be snug, but must not be so tight that they interfere with breathing. You should be able to slide your open hand, flat, between the belt and the rider.
3. A pelvic wedge or a similar device can help keep the rider from sliding down in the seat. Consult with the rider's doctor, nurse or therapist to find out if the rider needs such a device.
4. Use positioning belts only with a rider who can cooperate. Make sure the rider can easily remove the belts in an emergency.
5. NEVER Use Positioning Belts:
 - a. As a patient restraint. A restraint requires a doctor's order.
 - b. On a rider who is comatose or agitated.
 - c. As a motor vehicle restraint. In an accident or sudden stop the rider may be thrown from the chair. Wheelchair seat belts will not prevent this, and further injury may result from the belts or straps.

If you fail to heed these warnings damage to your chair, a fall, tip-over or loss of control may occur and cause severe injury to the rider or others.

I. PUSH HANDLES (Optional)**⚠ WARNING**

When you have an attendant, make sure that this chair has push handles.

1. Push handles provide secure points for an attendant to hold the rear of this chair, to prevent a fall or tip-over.
2. Check to make sure push handle grips will not rotate or slip off.

If you fail to heed these warnings damage to your chair, a fall, tip-over or loss of control may occur and cause severe injury to the rider or others.

J. QUICK-RELEASE AXLES**⚠ WARNING**

1. Do not use this chair UNLESS you are sure that both quick-release rear axles are locked.
2. An axle is not locked until the quick-release button pops out fully.
3. An unlocked axle may come off during use, resulting in a fall, tip-over or loss of control and cause severe injury to the rider or others.
 - Quick-Release Axles should be periodically cleaned and inspected for function and signs of wear or bending. Replace as necessary.

If you fail to heed these warnings damage to your chair, a fall, tip-over or loss of control may occur and cause severe injury to the rider or others.

K. REAR WHEEL**⚠ WARNING**

A change in set-up of the rear wheels will affect the center of balance of your chair.

1. The farther you move the rear axles FORWARD, the more likely it is that your chair will tip over backward.
2. Consult your healthcare advisor to find the best rear axle set-up for your chair. Do not change the set-up UNLESS you consult your healthcare advisor first.
3. Adjust the rear wheel locks after you make any change to the rear axles.
 - a. If you fail to do so, the wheel locks may not work.
 - b. Make sure lock arms embed in the tires at least 1/8 inch when locked.

If you fail to heed these warnings damage to your chair, a fall, tip-over or loss of control may occur and cause severe injury to the rider or others.

L. REAR WHEEL LOCKS**⚠ WARNING**

Rear wheel locks are NOT designed to slow or stop a moving wheelchair. Use them only to keep the rear wheels from rolling when your chair is at a complete stop.

1. NEVER use rear wheel locks to try to slow or stop your chair when it is moving. Doing so may cause a fall or tip-over
2. To keep the rear wheels from rolling, always set both rear wheel locks when you transfer to or from your chair.
3. Low pressure in a rear tire may cause the wheel lock on that side to slip and may allow the wheel to turn when you do not expect it.
4. Make sure lock arms embed in tires at least 1/8 inch when locked. If you fail to do so, the locks may not work.

If you fail to heed these warnings damage to your chair, a fall, tip-over or loss of control may occur and cause severe injury to the rider or others.

M. MODIFIED SEAT SYSTEMS**⚠ WARNING**

Use of a seat system not approved by Sunrise may alter the center of balance of this chair. This may cause the chair to tip over.

1. Do not change the seat system of your chair UNLESS you consult your authorized supplier first.
2. Use of a seating system not approved by Sunrise may affect the folding mechanism of this chair.
3. Use of a seating system not provided by Sunrise is prohibited for transit use.

If you fail to heed these warnings damage to your chair, a fall, tip-over or loss of control may occur and cause severe injury to the rider or others.

N. SEAT AND BACK UPHOLSTERY**⚠ WARNING**

1. Replace worn or torn fabric of seat and seat back as soon as you can. If you fail to do so, the seat or seat back may fail.
2. Sling fabric will weaken with age and use. Look for fraying, thin spots, or stretching of fabrics especially at edges and seams.
3. "Dropping down" into your chair will weaken fabric and result in the need to inspect and replace the seat more often.
4. Be aware that laundering or excess moisture will reduce the flame retardation qualities of the fabric.
5. If Tension Adjustable upholstery is present, loosen straps or remove upholstery prior to folding or unfolding the chair.

If you fail to heed these warnings damage to your chair, a fall, tip-over or loss of control may occur and cause severe injury to the rider or others.

The owner of this chair is responsible for making sure that it has been setup and adjusted by a trained service professional under the advice of a healthcare advisor. The chair may require periodic safety and function checks, or certain in-use adjustments that may be performed by the owner or caregiver. Always use parts and/or accessories that have been recommended or approved by Sunrise Medical when maintaining this chair.

A. INTRODUCTION

1. Proper maintenance will improve performance and extend the useful life of your chair.
2. Clean your chair regularly. This will help you find loose or worn parts and make your chair easier to use. You will need a mild detergent solution and plenty of cleaning rags.
3. If discovered, repair or replace loose, worn, bent or damaged parts **before using the chair.** ALWAYS be sure to use Parts and/or accessories that have been recommended or approved by Sunrise Medical.
4. To protect your investment, have all major maintenance and repair work done by your authorized dealer.
5. **Inspect and maintain this chair strictly per the maintenance chart.**
6. **If you detect a problem, make sure to order parts, or have service, and repair work done at your authorized dealer before use.**
7. **At least once per year, have a complete inspection, safety check, and service of your chair made by an authorized dealer.**

B. CRITICAL SAFETY CHECKS

1. **Tire Air Pressure:**
Check air pressure in pneumatic tires at least **ONCE PER WEEK.** The wheel locks will not grip properly if you fail to maintain the air pressure shown on tire sidewall.
2. **Axles & Axle Sleeves:**
When checking axles and axle sleeves every six months, make sure they are clean and tight.
Loose sleeves will damage the axle plate and will affect performance.

C. CLEANING TIPS

1. **Paint Finish**
 - a. Clean the painted surfaces with mild soap or detergent at least once a month.
 - b. Protect the paint with a coat of non-abrasive auto wax every three months.
2. **Axles and Moving Parts**
 - a. Clean around axles and moving parts **WEEKLY** with a slightly damp (not wet) cloth.
 - b. Wipe off or blow away any fluff, dust or dirt on axles or moving parts.
3. **Upholstery**
 - a. Hand-wash (machine washing may damage fabric).
 - b. Drip-dry only. **DO NOT** machine dry as heat will damage fabric.
4. **Basic Maintenance Materials available at local store**
 - a. Tire Pump
 - b. Tire pressure gauge.
 - c. Clean rags or cotten cloth.
 - d. Teflon-based Lubricant
 - e. Mild Detergent.

NOTE– You do not need to grease or oil the chair.

D. SAFETY CHECKLIST

Weekly	Monthly	3 Months	6 Months	Annually	Safety & Function Check
<input checked="" type="checkbox"/>					Tire inflation level
<input checked="" type="checkbox"/>					Wheel locks
		<input checked="" type="checkbox"/>			Visually check for loose hardware
			<input checked="" type="checkbox"/>		Armrests
			<input checked="" type="checkbox"/>		Axle and axle sleeves
		<input checked="" type="checkbox"/>			Quick-release axles
		<input checked="" type="checkbox"/>			Wheels, tires and spokes
		<input checked="" type="checkbox"/>			Casters
		<input checked="" type="checkbox"/>			Anti-tip tubes
			<input checked="" type="checkbox"/>		Frame, camber tubes, and crossbrace
	<input checked="" type="checkbox"/>				Upholstery
				<input checked="" type="checkbox"/>	Service by Authorized Dealer

NOTE - The user or caregiver should perform these weekly and monthly checks to maintain the safety of their chair. If an item is not working properly, please contact your authorized dealer.

E. TROUBLESHOOTING CHART

Symptom						Solution
	Left turn in chair	Right turn in chair	Looseness in chair	Sluggish turning	Squeaks and rattles	
<input checked="" type="checkbox"/>	<input checked="" type="checkbox"/>	<input checked="" type="checkbox"/>	<input checked="" type="checkbox"/>			Make sure tire pressure is correct and equal in both rear tires and front caster tires, if pneumatic.
		<input checked="" type="checkbox"/>	<input checked="" type="checkbox"/>	<input checked="" type="checkbox"/>	<input checked="" type="checkbox"/>	Make sure all nuts and bolts are tight.
		<input checked="" type="checkbox"/>		<input checked="" type="checkbox"/>		Make sure all spokes and nipples are tight on radial spoke wheels.
				<input checked="" type="checkbox"/>		Use Tri-Flow Lubricant (Teflon®-based) between frame connections and parts.
<input checked="" type="checkbox"/>	<input checked="" type="checkbox"/>		<input checked="" type="checkbox"/>		<input checked="" type="checkbox"/>	Check for proper caster fork adjustment. See instructions for caster fork adjustment.

F. TO MOUNT & REMOVE REAR WHEELS 11 12

WARNING

Do not use this chair **UNLESS** you are sure both quick-release axles are locked. An unlocked axle may come off during use and cause a fall.

NOTE— Setting the wheelchair on a flat surface, such as a workbench or table, helps make these procedures easier.

1. To Install Wheel

- a. Depress quick-release button (A) fully. This will release tension on ball bearings at other end.
- b. Insert axle (B) through hub of rear wheel.
- c. Keep button (A) depressed as you slide axle (B) into axle sleeve (C).
- d. Release button to lock axle in axle sleeve. Adjust axle if it does not lock. See Section B.
- e. Repeat steps on other side.

NOTE— The axle is not locked until the quick-release button pops out fully (A). Check that the axle is locked by pulling on the wheel in the direction of the axle.

2. To Remove Wheel

- a. Depress quick-release button (A) fully.
- b. Remove wheel by sliding axle (B) completely out of axle sleeve (C).
- c. Repeat steps on other side.

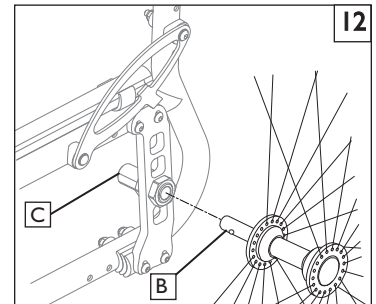
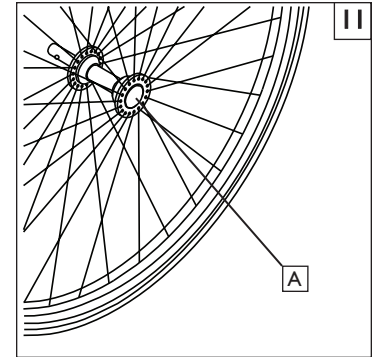

G. WHEEL LOCKS 13

WARNING

Wheel locks are installed at Sunrise and should be adjusted by your qualified service person. Inspect wheel locks weekly per the maintenance chart. Do not use your chair **UNLESS** you are sure both wheel-locks can fully engage. A wheel-lock that is not correctly adjusted may allow your chair to roll, or turn unexpectedly. Wheel-locks must be adjusted after making sure the tires have the correct air pressure. When fully engaged, the arm should be imbedded into the tire at least 1/8" to be effective.

If you find the wheel locks have slipped or are not working correctly contact your service provider for proper adjustment.

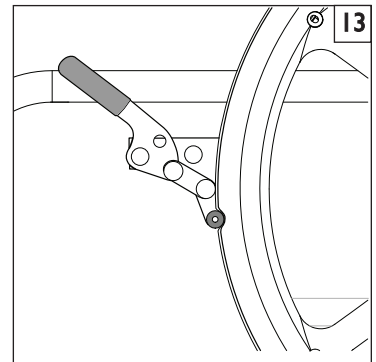

H. ANTI-TIP TUBES (OPTIONAL)

Quickie recommends anti-tip tubes for all wheelchairs.

1. Inserting Anti-Tip Tubes Into Receiver 14

- a. Press the rear anti-tip release pin (D) on the anti-tip tube so that both release pins are drawn inside.
- b. Insert into the anti-tip tube receiver.
- c. Turn the anti-tip tube down until release pin is positioned through the receiver mounting hole (E).
- d. Insert second anti-tip tube the same way.

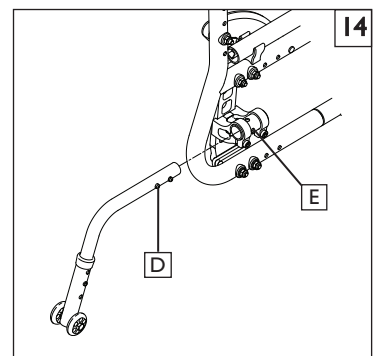

2. Adjusting Anti-Tip Tube Wheel 15

The anti-tip tube wheels may have to be raised or lowered to achieve proper clearance of 1 1/2" to 2".

- a. Press the anti-tip wheel release pin (F) so that the release pin is drawn inside.
- b. Raise or lower to one of the three predrilled holes.
- c. Release pin.
- d. Adjust the second anti-tip tube wheel the same way. Both wheels should be at exactly the same height.

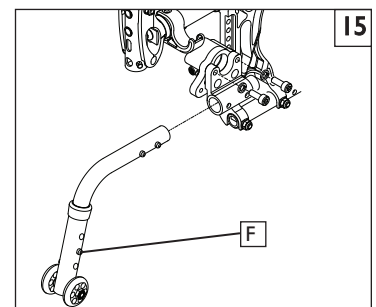

3. Turning Anti-Tip Tubes Up 16

- Turn anti-tip tubes up when being pushed by attendant, overcoming obstacles or climbing curbs.
- a. Press the rear anti-tip tube release pin (A).
 - b. Hold pin in and turn anti-tip tube up.
 - c. Release pin.
 - d. Repeat with second anti-tip tube.
 - e. Remember to return anti-tip tubes to down position after completing maneuver.

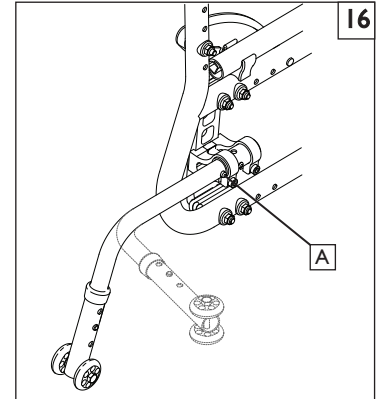

I. ARMRESTS 17

Sunrise medical offers several different types of armrests. Fixed, swing-away, and flip-back armrests. Swing-away armrests can be detached or can swing away to allow lateral transfers. They are height adjustable (1" increments) by squeezing the adjustment trigger and moving (4) up or down to the desired height.

1. Basic Installation

- a. Slide the outer armpost (4) into the receiver mounted to the wheelchair frame.
- b. The armrest should lock into place.

2. Height Adjustment

- a. Release the upper securing lever (2) .
- b. Slide armpad up or down to desired height.
- c. Return lever to locked position.

3. Removing Armrest

- a. To remove, grasp the unlocking lever (3) and pull up on the armrest..

4. Replacing Armrest

- a. Slide armrest back into receiver.
- b. Make sure that the unlocking lever (3) returns to the locked position against armpost

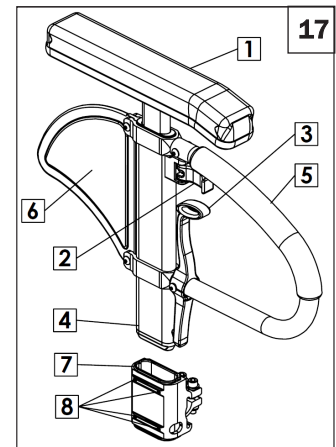

1. Armrest pad
2. Height Release Lever
3. Release lever
4. Outer armpost
5. Transfer bar
6. Side panel
7. Receiver
8. Receiver adjustment hardware

⚠ WARNING

Armrest should not be used for lifting or carrying the wheelchair. Always check that the armrests are correctly engaged. There is a risk of trapping fingers when adjusting the armrests.

J. PADDED SWING-AWAY ARMRESTS 18

1. Installation

Slide armrest into receiver tube (B) on rear of frame.

2. Swinging Away

Lift armrest out of locked position and rotate to the side.

3. Removing Armrest

Pull armrest straight out of receiver.

The Padded Swing Away Armrest is primarily used for resting the forearms of the chair's occupant. It is not designed to be a transfer arm for the wheelchair. You should always remove the the armrests or swing them out of the way during transfers. The armrests are not designed to be used for any activity that puts full body weight on them, such as transferring using this armrest. Failure to follow these instructions can result in severe injury, decreased chair integrity and may void the warranty.

⚠ WARNING

Padded swing away armrests are not transfer devices and must be rotated out of the way prior to transferring. Failure to do this on a regular basis can result in decreased chair integrity and may void the warranty.

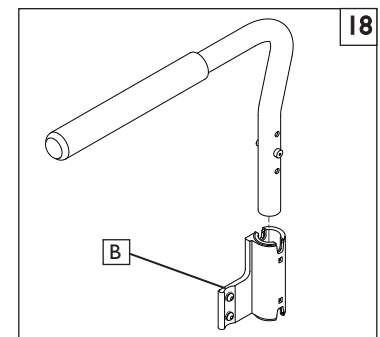

K. FOOTRESTS, LEGRESTS, & FOOTPLATES 19

Make sure that your Sunrise dealer has correctly adjusted your footrests and/or legrests with the advice of a healthcare professional. The original setup should not be changed without first checking with that advisor. The footrest position is key to keeping your body in the proper alignment, and providing a stable support for your legs and torso. Legrests and footrests should be swung out of the way, or removed for transfers.

Swing-in Swing-out hangers and footrests

1. Basic Footrest Installation

- a. Place swing-in/swing-out pivot saddle into the receiver (A) on the front frame tube with the footrest facing inward or outward from the frame.
- b. Rotate the footrest inward until it locks into place on the locking plate.

2. Removal

- a. To remove footrest, release latch (B) by pulling lever upward or pushing lever downward.
- b. Rotate the footrest inward or outward and lift it off of the chair.

3. Flipping up the Platform Footplate 20

Flip-up the Footplate when transferring from your wheelchair.

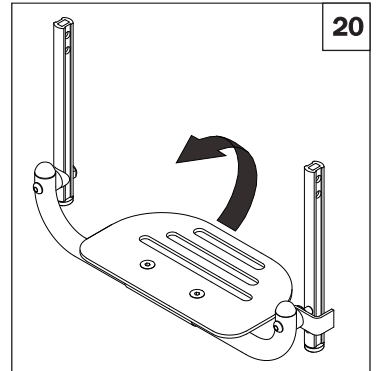
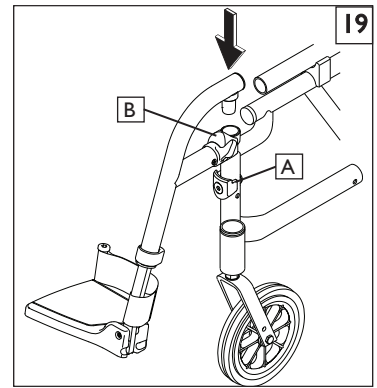

L. Z-FINITY™ FOOTRESTSYSTEM 21 22

CAUTION– The Z-Finity™Footrest system is rated to 165lbs (75kg)

With the footrest system, Sunrise Medical offers either a single Flip-up Footplate (B), or dual footplates (C) that are able to accommodate all of the possible heights and adjustment angles that the rider may require for their comfort and support.

Z-FINITY™ SWING-AWAY FOOTREST 22 23

The footrest system can also accommodate a swing-away hanger (D) with dual footplates (C) that are both height adjustable and angle adjustable.

Swing-in-Swing-out Hangers and Footrests (80°)

1. Basic Footrest Installation

- a. From the side, place the pivot (E) into the top of the frame tube which guides the hanger into the correct alignment with the locking plate (F) on front frame tube.
- b. Rotate the footrest towards the front of the chair until it locks into place on locking plate.

2. Removal

- a. To remove footrest, release latch (G) by pulling lever upward or pushing lever downward.
- b. Rotate footrest inward or outward and lift.

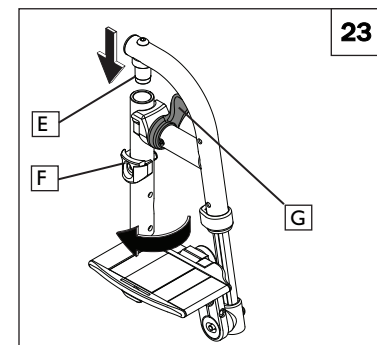
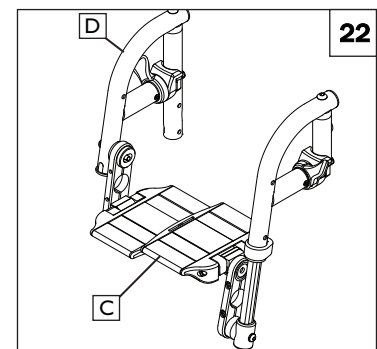
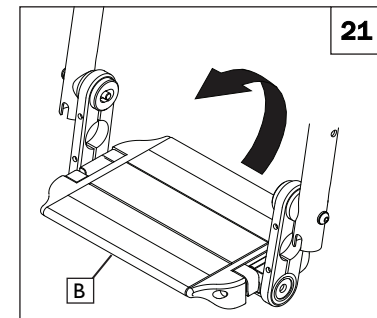

M. BACKPOSTS AND INTEGRAL PUSH-HANDLES 24

Quickie2 Lite wheelchairs are shipped with either straight backcanes, push-handle backcanes, or a backcane with an integral folding push-handle. The folding push-handles (C) come in the folded position.

I. Using the Integral Push-handles

- a. Lift the Handle (C) to the upright position it should lock in place.
- b. To unlock and fold the push-handles when not in use, press the unlock button (D) and push the handle back into the folded position.

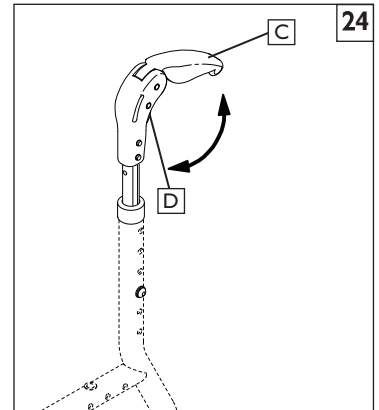
**N. SEATING AND SEAT SLING UPHOLSTERY** 25

The seat sling can be adjusted through the use of hook and loop material beneath the seat. The seat sling also includes a folding strap on the seat to assist in folding the chair.

NOTE- The seat sling folding strap is not intended as a carrying strap.

I. Adjustment

- a. Remove seat rail end caps at the front of the chair (E).
- b. Slide the seat sling, plastic retaining rods, and spacers (if present from the channels in the seat rails).
- c. Readjust hook and loop material to obtain the desired tension in the seat sling.
- d. Re-insert the seat sling and plastic retaining rods into the channels in the seat rails.
- e. Replace the end caps (E).

2. Seat Sling Upholstery

- a. Check monthly for excessive stretching of the upholstery, or loose attaching hardware. If you determine the upholstery can no longer be adjusted tight, contact your service representative for a replacement.

3. Cushion Installation

- a. Place cushion on the seat sling with the hook material side down. The beveled edge of the cushion should be facing toward the front of your chair.
- b. Press firmly into place.

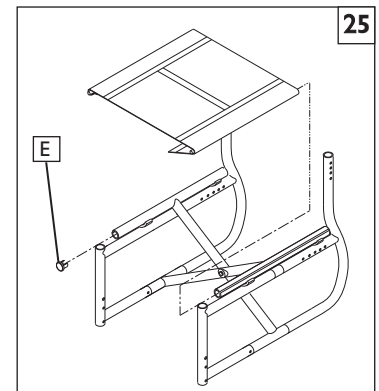

O. SIDE GUARDS

26

Inserting and Removing the Side Guard

- a. Insert the Side Guard (A) into the outer receiver hardware (B).
- b. To remove the Side Guard, grip the top on the handle area and pull upward.

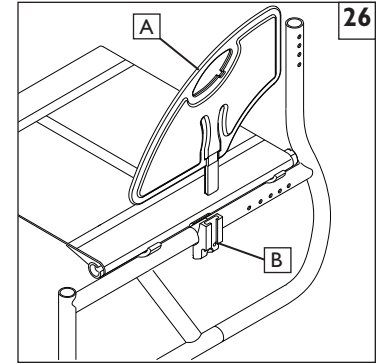

26

P. FOLDING AND UNFOLDING**⚠ WARNING****Possible pinch point! BE CAREFUL.**

1. If the seat sling is not present during folding and unfolding, hold the top of the seat rail securely without wrapping fingers around the seat rail.
2. Use flat palms to depress the chair if you are opening or unfolding the chair.

⚠ WARNING

IF YOU HAVE TENSION ADJUSTABLE UPHOLSTERY, loosen straps or remove upholstery prior to folding or unfolding the chair.

1. Folding the Wheelchair

- a. Remove quick-release wheels (optional).
 - Depress quick-release button on the axle.
 - Remove wheel by sliding out quick-release axle from axle bracket.
 - Repeat with other wheel.
- b. For the Swing Away model, flip up the footrest to a vertical position before folding the wheelchair.
- c. Grasp the seat sling (in the center) and lift sharply until the wheelchair is folded.

2. Unfolding the Wheelchair

- a. Replace quick-release wheel (optional) by depressing the quick-release button on the axle.
- b. Slide it into the axle sleeve until it locks.
- c. Repeat with other wheel.
- d. Tilt the wheelchair toward you far enough to take the weight off the opposite wheel.
- e. Push down on the seat rail (closest to you) until the wheelchair is completely opened.
- f. Make sure seat rail tubes are resting in the seat rail saddles.

NOTE— Ensure that footrests are locked prior to use.

Q. STORAGE TIPS

1. Store your chair in a clean, dry area. If you fail to do so, parts may rust or corrode.
2. Before using your chair, make sure it is in proper working order. Inspect and service all items on the "Maintenance Chart".
3. If stored for more than three months, have your chair inspected by an authorized supplier before use.

R. INSPECT

After the wheelchair is assembled and adjusted, it should roll smoothly and easily. All accessories should also perform smoothly. If you have any problems, follow these procedures:

1. Review the set-up and check out sections and operating guide to make sure chair was properly prepared.
2. Review troubleshooting guide.
3. If your problem persists, contact your authorized supplier. If you still have a problem after contacting your authorized supplier, contact Sunrise customer service. See the introduction page for details on how to contact your authorized supplier or Sunrise customer service.

⚠ WARNING

The owner of this chair is responsible for making sure that it has been setup and adjusted by a trained service professional under the advice of a healthcare advisor. Service and/or adjustments should only be done with the advice of a healthcare professional. Always use parts and/or accessories that have been recommended and approved by Sunrise Medical when servicing this chair.

A. DEALER SERVICE INTRODUCTION 27

1. At least once per year, this chair should have a complete inspection, safety check, and regular service made by an authorized dealer. The tools at right are a good start for proper maintenance.
2. Torque settings— A torque setting is the optimum tightening which should be made on a particular fastener. It is important to use proper torque settings where specified. When not specified, torque settings should be 60 in-lbs.
3. If you have discovered a worn, bent, or damaged part, repair or replace them with recommended parts **before returning this chair to service.**
4. All major maintenance and repair work should be done by the authorized dealer.

B. CRITICAL MAINTENANCE TIPS**1. Torque settings:**

A torque setting is the optimum tightening which should be made on a particular fastener. It is important to use proper torque settings where specified. When not specified, torque settings should be: M5 fasteners = 44 in-lbs (5 Nm), M6 fasteners = 62 in-lbs (7 Nm), M8 fasteners = 88 in-lbs (10 Nm). For all others torque setting should be 60 in-lbs (6.8 Nm).

2. Dealer Service and Adjustment Reference materials:

Go to www.sunrisemedical.com for parts manuals, instruction sheets, and instructional videos that will aid in the repair of the Quickie 2 Family of wheelchairs.

C. CLEANING**1. Paint Finish**

- a. Clean the painted surfaces with mild soap or detergent.
- b. Protect the paint with a coat of non-abrasive auto wax.

2. Axles and Moving Parts

- a. Clean around axles and moving parts with a slightly damp (not wet) cloth.
- b. Wipe off or blow away any fluff, dust or dirt on axles or moving parts.
- c. **DO NOT USE 3 in 1 oil, or WD-40 ® for lubrication.** Only use Teflon based Lubricant when working on this wheelchair.

D. REAR AXLES AND AXLE PLATES

The most important adjustment on your Quickie wheelchair is the position of the rear axle. The center of gravity, wheel camber and wheelbase are all determined by the axle adjustment.

⚠ WARNING

The more you move your rear wheels forward, the more likely your chair will tip over backwards. Always make adjustments in small increments, and check the stability of your chair with a spotter to prevent a tip-over. We recommend that you use anti-tip tubes until you adapt to the change and are sure you are not at risk to tip over. Refer to additional Warnings in Section VI "Falls and Tip-Overs".

NOTE— Adjusting your chair's center of gravity will require re-adjusting the location of the wheel locks

1. Center of Gravity 28

Moving the center of gravity to the front will lighten the force required to turn the chair. The further back the axle, the more stable the chair becomes.

- a. Remove four retaining bolts (A), nuts and camber spacers on axle plate (B).
- b. Move axle plate forward or rearward to desired position.
- c. Insert all four bolts and camber spacers back into place on frame. Tighten nuts.
- d. Repeat on opposite side of wheelchair.
- e. Axle plate and camber must be exactly the same on both sides of the wheelchair.

2. Wheel Camber 29

The wheel camber adjustment provides greater side-to-side stability due to the increased width and angle of the wheelbase. The wheel camber adjustment also allows for quicker turning and greater access to the top of the handrims. More or less camber can be obtained by increasing or decreasing the number of camber spacers (C) located between the lower axle plate attachment (D) and frame (E).

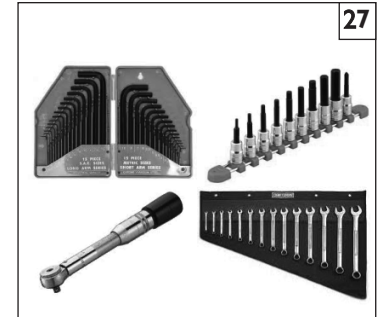
**TOOLS YOU WILL NEED**

1. Imperial Hex key set
2. Metric Hex key set
3. Imperial Open-end Wrench set
4. Metric Open-end Wrench set
5. Torque wrench
6. Imperial Hex bit Socket set
7. Metric Hex bit Socket set
8. Phillips and Flat screwdrivers

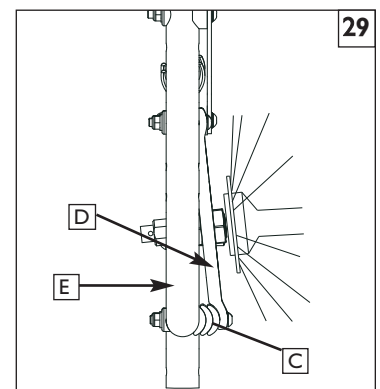
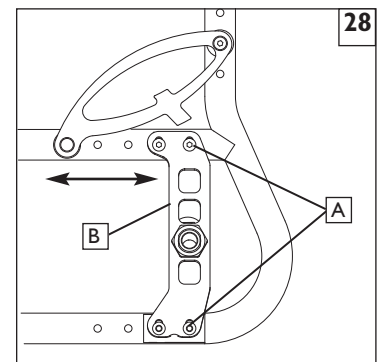

3. Wheel Base Width Adjustment

Adjusting the wheelbase width allows the rider the option to move the wheels closer or further away from the hips. It also compensates for camber adjustment and gives the proper wheel spacing to maximize pushing efficiency.

Adjust the wheelbase width by: 30

- a. Loosen the nuts (A) and reposition the axle sleeve (B) to the desired width.
- b. Retighten nuts.

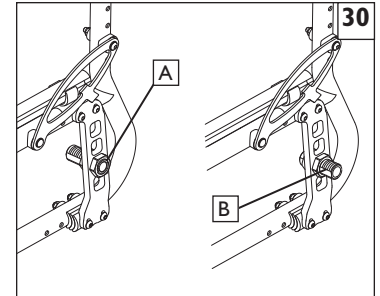

Adjustment with Anti Tip Hardware:

NOTE—Before adjusting wheel base estimate distance the rear wheels need to move in or outward.

- a. Remove outside nut.
- b. Remove anti tip receiver hardware with axle sleeve.
- c. Thread axle sleeve in or out as desired, ensuring that the final position leaves the flats of the axle sleeve parallel to the rear of the anti tip receiver.
- d. Insert anti tip receiver hardware with axle sleeve through desired hole of the axle plate from the inside of the wheelchair.
- e. Re-install and tighten outside nut.
- f. Repeat on opposite side of wheelchair.

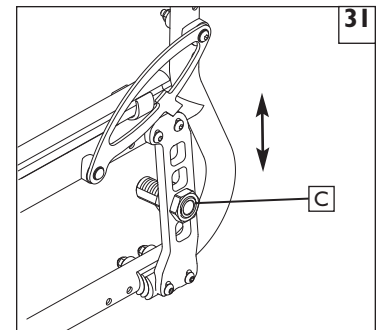

4. Seat Height Adjustment 31

Seat height can be adjusted by repositioning the axle sleeve (C) vertically in one of the predrilled holes in the axle plate. Switch axle plates left to right (and upside down) for 1/2" adjustments.

NOTE— A front caster adjustment should be made to correspond with any change in seat height.

E. REAR WHEEL AXLE NUT ADJUSTMENT 32 33

Tight axle sleeves should be maintained for proper performance of the wheelchair.

- a. To adjust the axle (D) you will need a 3/4" wrench (E) to turn the outside axle nuts (F).
- b. You will also need a 1/2" wrench to lodge the ball bearings (G), on the opposite end of the axle, and pre-vent the axle from turning.
- c. Turn the outside axle nut (F) clockwise to tighten.
- d. There should only be zero to ten thousandths of an inch (.010") of play.
- e. Check to make sure that the quick-release button (H) is flush with the edge of the wheel.

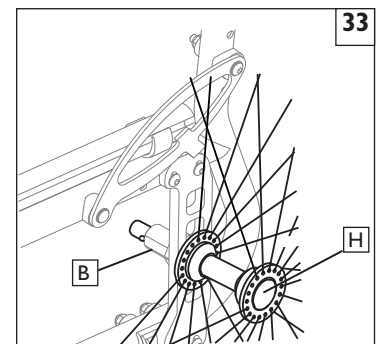
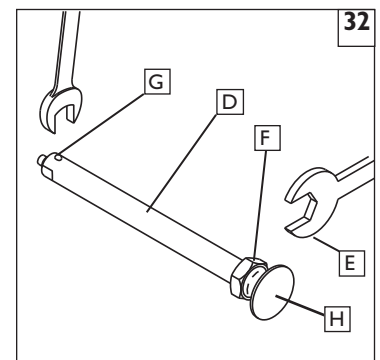

F. SQUARING THE ANTI-TIP TUBES 34

I. Squaring Anti-tip Tubes

When camber is added to rear wheels, anti-tips must be adjusted to be square to the center line of the chair.

- a. Loosen both screws (I) so that anti-tip receiver can be rotated.
- b. Rotate anti-tip receiver and anti-tip until anti-tip is square to the floor at the center of the chair.
- c. Retorque fasteners on anti-tip receiver to 100 in-lbs.
- d. Repeat for opposite side.

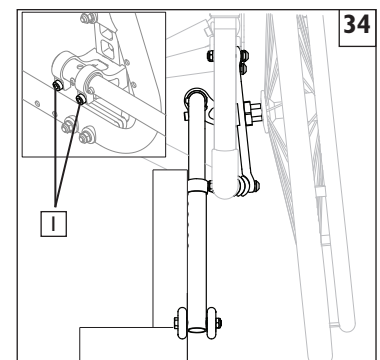

G. WHEEL LOCKS 35 36

The Quickie 2 Lite wheelchair is shipped with one of four types of wheel locks. Wheel locks are installed at the factory unless you have requested otherwise.

Use a torque setting of 115 in-lbs when setting up wheel locks.

1. High-Mount Push-to-Lock or Pull-to-Lock Wheel Locks Adjustment

- a. Using a 3/16 inch hex key, turn one of the screws (A) in the clamp counterclockwise one-quarter turn.
- b. Repeat the same process with the second of the two screws.
- c. Alternately loosen the screws (two turns each) until both screws are removed.
- d. Slide clamp toward the rear wheel until the wheel lock is embedded into the tire to prevent wheel movement, when in the locked position.
- e. Tighten screws to 115 in-lbs.

2. Ergo Scissor Wheel Locks or Compact Wheel Locks

Loosen the screws (B) on the top of each clamp using a 3/16 inch hex key. Slide assembly toward rear wheel until clamp embeds into tire to prevent wheel movement when in locked position. Adjust angle position. Tighten screws to 115 in-lbs.

NOTE– Clamp and wheel lock may need to be rotated to clear frame tubing.

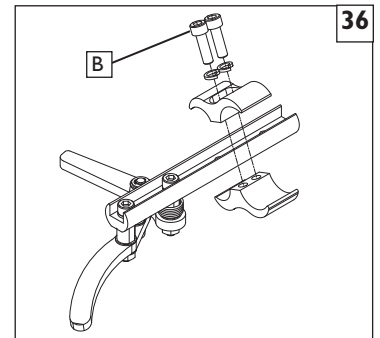
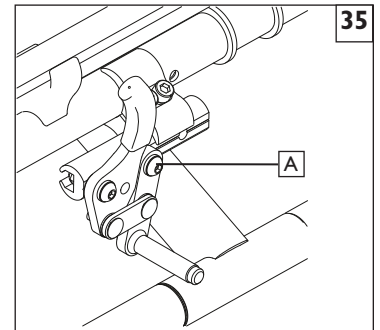

H. CASTER FORKS 37

Two-hole caster (C) forks allow the interchanging of some casters and adjusting seat height. To adjust, loosen the bolt and remove the caster. Either change caster size and/or position the caster upward or downward in predrilled holes (1 inch apart) on caster fork. Replace bolt and tighten securely.

Use a torque setting of 75 in-lbs when adjusting the casters.

I. CASTERS

NOTE– Setting the wheelchair on a very flat table or a workbench makes this setting more accurate.

NOTE ON TORQUE SETTING – A torque setting is the optimum tightening which should be made on a particular fastener. Use proper torque settings when specified.

1. Caster Angle 38

Checking for Caster Squareness:

Your Quickie wheelchair leaves the factory with the casters adjusted square. Any time you change your wheelchair rear axle height, rear tire size, center of gravity position or camber tube, you should check that the casters are still square. A caster that is not square will result in the caster lifting off the floor as it rotates around the stem bolt and may also lift the front of the wheelchair up and down. Check for squareness by placing your wheelchair on a flat, horizontal surface. Rotate both forks so that the casters are towards the rear of the wheelchair. Place a square (D) or pocket level against the flat surface on the rear of the fork and note whether this surface is vertical (square). If this surface is more than 2 degrees away from vertical, your casters require re-squaring.

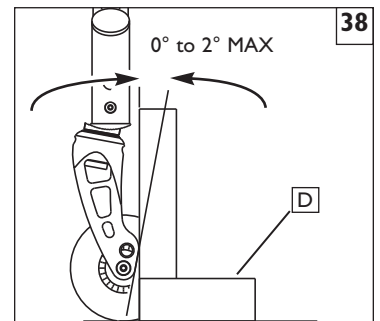
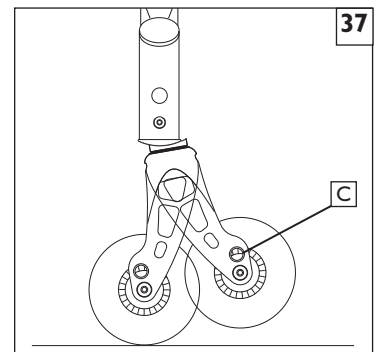

Casters continued

Use a torque setting of 75 in-lbs when adjusting the casters.

1. Caster Angle Adjustment 39

For optimum performance, the caster housing should always be at a 90° angle to the floor (perpendicular to the ground). This adjustment is made with an eccentric (offset) attachment bolt mechanism.

- a. To change the angle, place the chair on a flat surface (such as a table).
- b. Remove the bolt and nuts from the back side of the caster plate. The caster plate is slotted at the top and bottom for adjustment.
- c. Place a large right triangle against the table surface and the front surface of the caster bearing housing.
- d. This will align the caster stem rotational axis perpendicular to the floor surface.
- e. Rotate the bolts independently until they fall into position.
- f. When the alignment is correct, retighten the two retaining bolts.
- g. Repeat the process for the other caster.

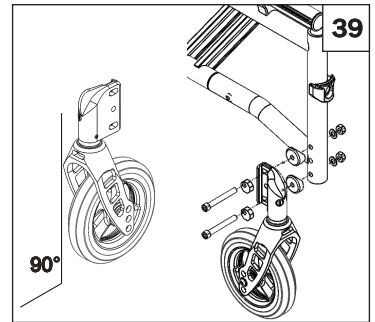

2. Caster Reversibility 40

The caster housing is generally mounted in a forward-facing position. If additional footrest clearance is necessary, the caster housing can be reversed. This will position the caster housing rearward to allow more clearance.

- a. To reverse the caster housing, the left housing should be mounted on the right side of the frame.
- b. The right housing should be mounted on the left side of the frame.

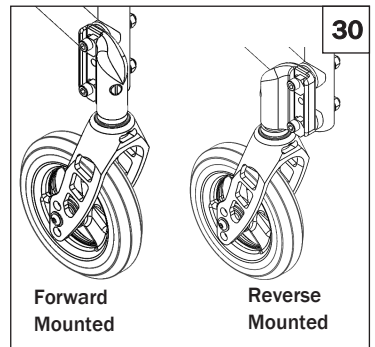

3. Fixed Front Frame Caster Housing Adjustment 41

To reposition the caster housing hardware for Quickie 2 Lite Fixed Front

- a. Remove cotter clip (D) from pin (E).
- b. Using a 7/16 wrench remove two caster housing bolts (F)
- c. Remove clevis pin (E).
- d. Reposition caster housing hardware onto frame lining up with preset holes.
- e. Insert clevis pin (E), insert and retighten two caster housing bolts (F)
- f. Reinsert cotter clip (D)

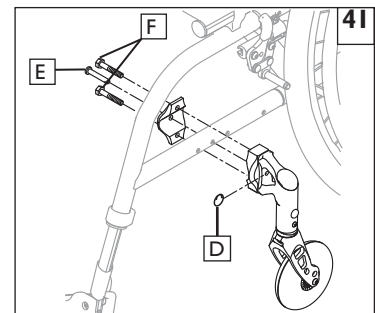

⚠ WARNING

After repositioning the caster housing always check for interference with footrest or rear wheel. Do not operate a wheelchair that has interference with these components. Ensure the caster fork is square. Additionally, repositioning the caster housing will affect the wheelchair's stability. Check the stability of your wheelchair with a spotter to prevent a tip-over.

J. ANTI-TIP RECEIVERS 42

Sunrise Medical recommends anti-tip tubes for all wheelchairs.

I. Adjustment with Anti Tip hardware:

NOTE- Before adjusting the wheel base, estimate the distance the rear wheels need to move in or outward.

- a. Remove the wheels to gain access to the axle plate (G).
- b. Remove the outside nut (H).
- c. Remove the anti-tip receiver hardware with the axle sleeve (I).
- d. Thread the axle sleeve in or out as desired, ensuring that the final position leaves the flats of the axle sleeve parallel to the rear of the anti-tip receiver.
- e. Insert the anti-tip receiver hardware with the axle sleeve through the desired hole of the axle plate from the inside of the wheelchair.
- f. Re-install and tighten the outside nut (H).
- g. Repeat on the opposite side of the wheelchair.

Use a torque setting of 115 in-lbs when setting up the anti-tip tube receivers.

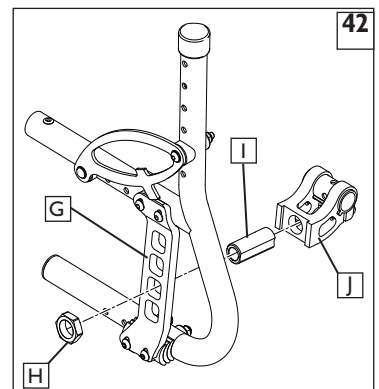

K. ARMREST RECEIVER ATTACHMENT 43 44 45 46

Mounting

1. Place the two clamp receivers (A) over the top portion of the rear side frame tube. Align with the single post height-adjustable armrest.
2. Pinch both clamp receivers together at the armrest receiver side and insert into the armrest receiver .
3. Once inserted, pinch both clamp receivers together on the far side of the armrest receiver.
4. Hold both clamp receivers against the top portion of the rear side frame tube and fasten (C).

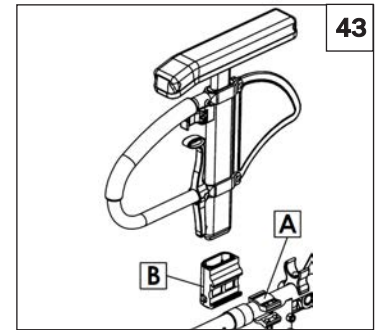

Adjustment

1. To adjust the fit of the Single Post Armrest in the receiver, loosen the 4 set screws (D) by using a 5/64" Hex Key .
2. With the armrest assembly in the receiver (B), press firmly on the outside of the receiver.
3. Maintain pressure on the receiver and re-tighten two of the set screws (D).
4. Remove the armrest assembly and re-tighten the remaining two set screws.
5. The armrest will fit firmly in the receiver and lessen any noise that may result from vibration.

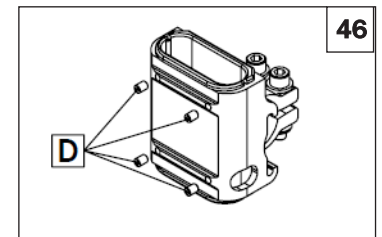
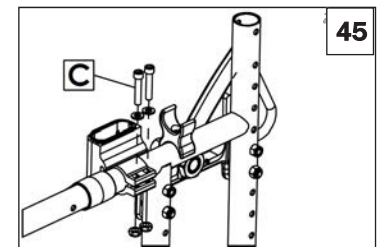
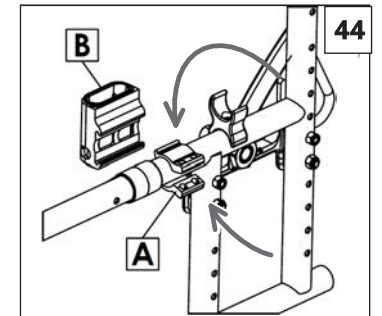

L. PADDED SWING-AWAY ARMRESTS 47

Swing-away armrests (F) can be detached or can swing away to allow lateral transfers. They are height adjustable (1" increments) by moving bolt (E) up or down in pre-drilled holes on armrest bracket.

Additional height can be achieved by removing bolts (G), flipping and rotating the receiver to opposite side (H). Ensure bolts (G) are re-tightend.

Swing-away, removable armrests are installed by sliding armrest into receiver (H) on back frame.

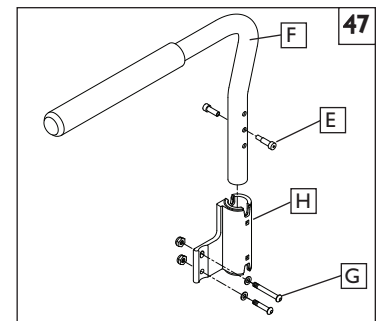

M. SWING-IN/SWING-OUT HANGERS AND FOOTRESTS 48

(70°, 80°)

1. Height Adjustment

NOTE- It is recommended that you maintain a minimum of 2.0 inches between the lowest point on the footrest and the floor.

- Loosen set screw (B) using a 3/16 inch hex key.
- Slide footrest extension up or down inside frame tube to desired height.
- Tighten set screw. Use a torque setting of 144 in-lbs (16.27 Nm).

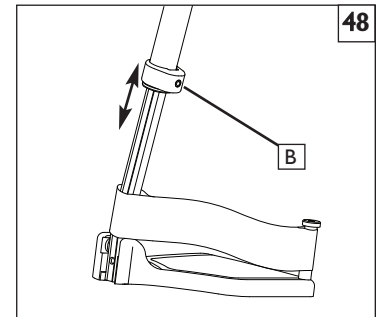

N. ANGLE ADJUSTABLE FOOTPLATES 49 50

1. Composite Angle Adjustable Footplates

- Remove bolt (C).
- Pull footplate section (D) away from extension.
- Reposition footplate back onto extension in new angular position. Use premarked extension coupling (E) as guide.

2. Aluminum Angle Adjustable Footplate

- Loosen screws (G).
- Adjust footplate (F) to desired angular position.
- Re-tighten screws (G).

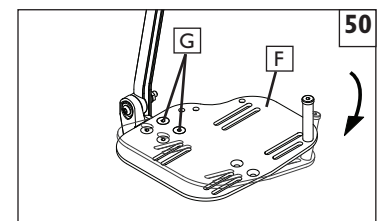
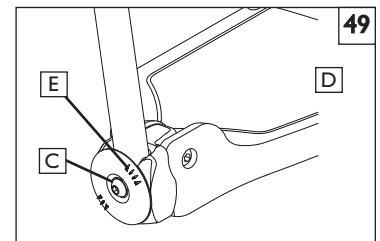

O. PLATFORM AND AUTO-FOLD FOOTRESTS 51 52

1. Platform Footrest Height adjustment

- Loosen the set screw (H) on both sides of the chair.
- Adjust the Footrest assembly up or down, making sure there is at least 2 inches between the Footrest and the floor.

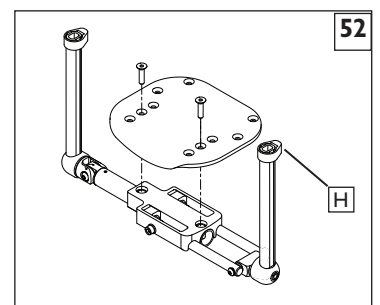
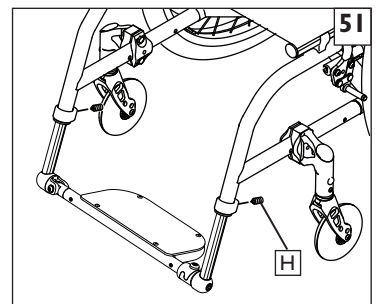

P. Z-FINITY™ FOOTREST SYSTEM

53 54 55

CAUTION– The Z-FINITY™ Footrest system is rated to 165 lbs (75 kg)

The footrest position is key to keeping the body in the proper alignment, and providing a stable support for your legs and torso. Make sure that your Sunrise dealer has correctly adjusted your footrests and/or legrests with the advice of a healthcare professional. The original setup should not be changed without first checking with that advisor. Legrests and footrests should be swung out of the way, or removed for transfers.

NOTE – Footplate must have at least 2 inches of clearance between the footplate and the ground to prevent hitting obstacles and risking a fall or tip-over.

1. Footrest/Footplate positioning using the rotational clamp

- Loosen the two rotational/angle clamp screws (D).
- Rotate the footrest/ footplate until the desired position and angle is achieved.
- Tighten the Clamp hardware to proper torque (DO NOT EXCEED a 120 in-lb Max torque).

2. Footrest positioning using footplate spacers

- Remove footplate spacers (E).
- Slide footplate to desired depth position.
- Replace footplate spacers.

3. Height range adjustment (Direct Mount Footrest)

- Adjust the footplate mounting position by removing the button head screw from the adjustment hole and moving the assembly to the desired position.
- Tighten hardware to proper torque (120 in-lb Max).

4. Height range adjustment (Extension Mount Footrest)

- Loosen set screw (F).
- Slide footrest extension tube up or down inside frame tube to desired height.
- Tighten set screw to proper torque (120 in-lb).

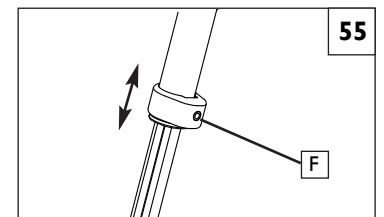
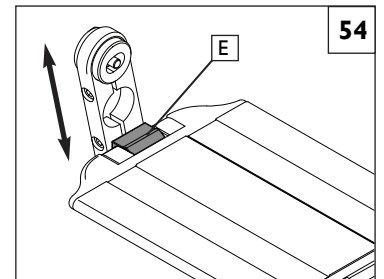
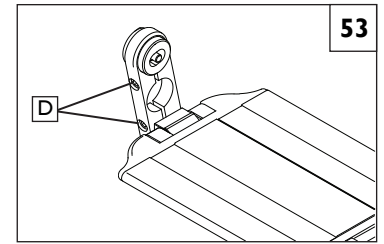

Q. BACKREST 56**1. Height Adjustment**

- Remove the backrest upholstery from the frame.
- You will see the backrest tube which telescopes into the frame and is secured by a screw (A) on the side of the frame.
- There are holes 1 inch apart that you may choose from to set the back height.
- Remove the two backrest bolts from the rear frame tubes.
- After selecting the proper height, insert bolt through frame and backrest tube.
- Slide the backrest upholstery back over both backrest tubes.

NOTE— Use a torque setting of 144 in-lbs when adjusting backrest.

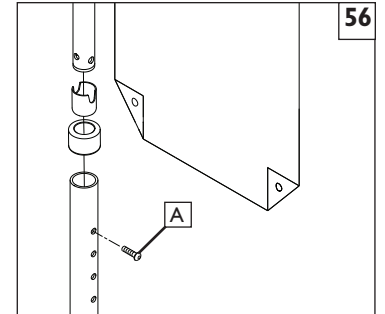
**R. ANGLE ADJUSTABLE BACKREST (Option)****1. Angle Adjustment** 57

- Loosen button head screws (B) until the eccentric offset washer (C) moves freely.
- Adjust backrest to desired angle, aligning eccentric offset washer in slot.
- Tighten button head screws.
- Repeat for opposite side.

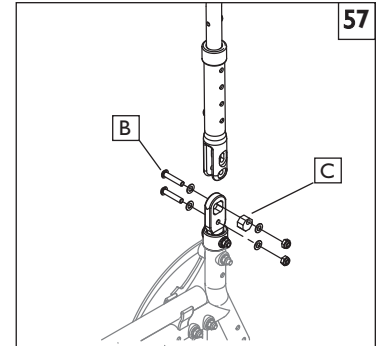
**2. Pivot Point Height Adjustment** 58

- Remove button head screw (D) from the frame.
- Adjust backrest to obtain desired pivot point height.
- Replace and tighten button head screw.
- Repeat for opposite side.

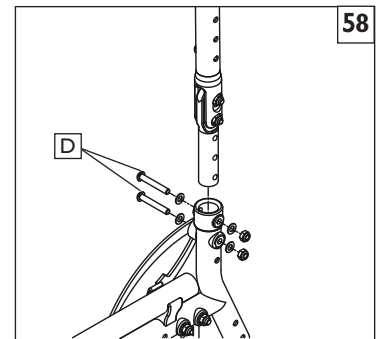
**3. Angle Adjustable Backrest Height Adjustment** 59

- Remove button head screw (E).
- Adjust back tube to desired height.
- Replace and tighten button head screw.
- Repeat for opposite side.

NOTE— Use a torque setting of 144 in-lbs when adjusting backrest.

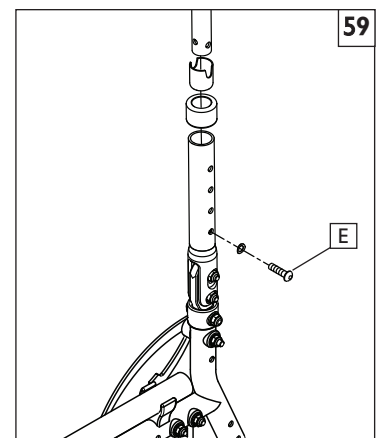

S. BACKREST TENSION ADJUSTABLE 60 61 62 63**To install the Backrest Tension Adjustable**

1. Slide Velcro straps (A) over the backrest frame (B) section. Make sure to include at least one strap below the towel bar (if using a rigid chair).
2. Tighten the straps appropriately to desired tension level. **DO NOT** overtighten straps as this will cause undue strain upon the chair backrest frame (B).
3. If using fold down push handles, insert the single Velcro strap (C) through the slots in the front of the push handles (D).
If using integral push handles (E), slide straps from bottom of backrest upward.
4. Install backrest cover at desired level and fold over rear of Velcro strapping system (F). The Quickie patch should be upright on the rear of the chair.
5. Finish installation by placing vanity flap (center panel) down onto Velcro on the seat sling to secure attachment (G).

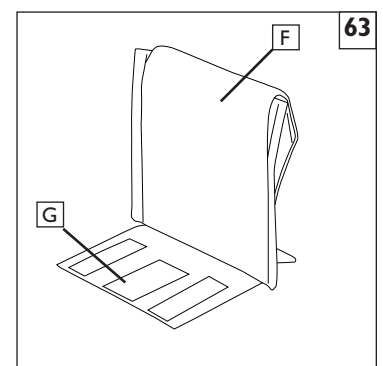
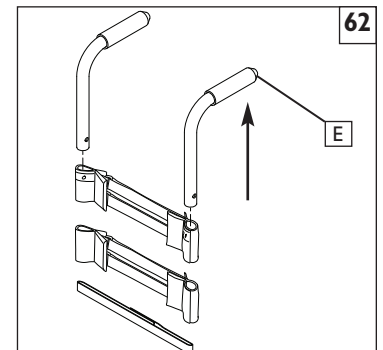
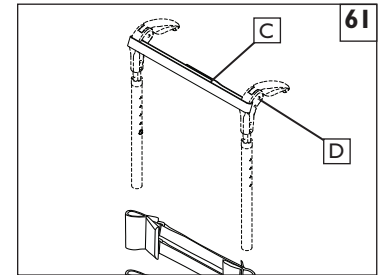
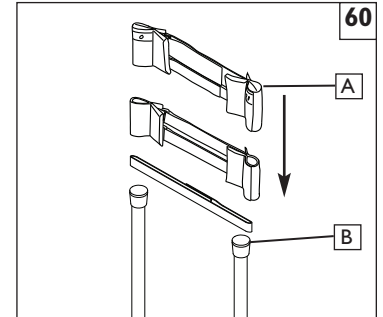
**Adjusting the Backrest Tension Adjustable**

Suggest using anti tips while making any adjustments. Ensure anti tips are safely secured and in a position to prevent the wheelchair from tipping backwards.

1. User can transfer into wheelchair. Place wheel locks in the locked position
2. From the rear of the wheelchair the attendant can lift the Vanity Flap (Center panel) to access the strap system. Adjust straps for optimal balance and trunk alignment. Ensure the Velcro straps has a minimum of 2 inches of engagement, hook securing to loop. Press the Velcro together to ensure it's securely engaged.
3. Once adjustments have been finalized replace Vanity Flap to its original position.

⚠ WARNING

Any changes made to the straps will affect the center of gravity. Suggest the user has the attendant stationed behind the wheelchair to prevent the wheelchair from tipping backwards while they become accustomed to the adjustment.

T. REMOVING SEAT RAILS 64

Detach seat rails by removing the two bolts (G) attaching the seat rail (F) to the cross brace.

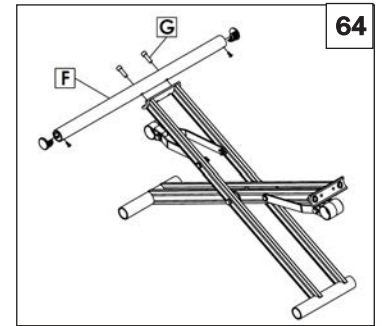

U. SEAT SADDLE ADJUSTMENT 65

The Quickie 2 features two seat rail connection settings using a reversible seat saddle (C). The “dynamic” position (shown) allows for a more rigid seat rail connection. The “classic” position (not shown) provides the current tension ideal for folding and unfolding the chair.

To adjust the saddle into either “classic” or “dynamic” position, simply remove the allen bolt (D), reverse the saddle (C) and retighten.

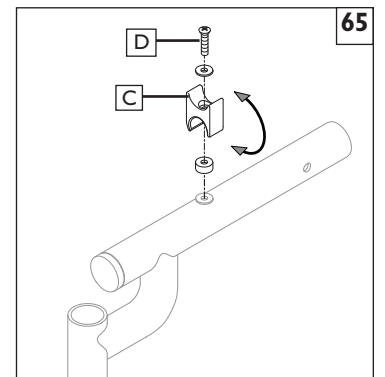

V. SIDEGUARD HARDWARE 66

Installation of sideguard hardware

- a. Position outer receiver hardware (E) on frame.
- b. On corresponding inside of the frame position inner clamping hardware (F)
- c. Insert two bolts (G) with washer and tighten using 3/16 inch hex key
- d. Your sideguard (H) can now be inserted into the receiver.

NOTE— After installing the receiver hardware and inserting the side guard, check for interference. Don't operate the wheelchair if the side guard interferes with any of the other components.

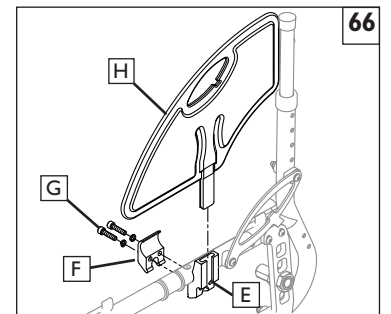

W. LIMB SUPPORT 67

See Swing Away Hangers/Footrests (Pg. 18) for installation/removal from chair.

1. Height Adjustment 68

- a. Loosen 2 screws (A), do not remove, slide post up or down to desired height.
- b. Re-tighten screws.

2. Angle Adjustment

- a. Press button (B) adjust up or down to desired angle, release button.

3. Length Adjustment

- a. Loosen 2 screws (C), do not remove, slide clamp forward or back for desired length.
- b. Re-tighten screws.

4. Additional Width or Length Adjustment

- a. Remove 2 screws (D), reposition to desired setting and replace screws.
- b. Tighten securely.

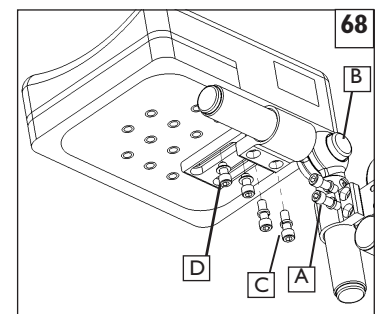
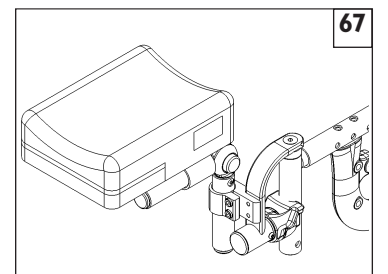

A. FOR LIFETIME

Frame and cross-brace (if applicable) warranty:

1. Although the anticipated useful service time of this wheelchair is five years, Sunrise guarantees the frame and cross brace against defects in material and workmanship for life or for as long as the original purchaser owns the chair.
2. This warranty does not apply if:
 - a. The chair is subject to abuse
 - b. The chair is not maintained as recommended in the owner's manual
 - c. The chair is transferred to a different person from the original owner

B. FOR ONE (1) YEAR

We warrant all Sunrise-made parts and components of this wheelchair against defects in materials and workmanship for one year from the date of first consumer purchase.

Backrest Tension Adjustable (Ballistic & 3DX Vented)

Each Backrest Tension Adjustable is carefully inspected and tested to provide peak performance. Every Backrest Tension Adjustable is guaranteed to be free from defects in materials and workmanship for a period of twelve (12) months from the date of purchase provided normal use. Should a defect in materials or workmanship occur within twelve months from the original date of purchase, Sunrise Medical will, at its option, repair or replace it without charge. This warranty does not apply to puncture, tears or burns. Claims and repairs should be processed through the nearest authorized supplier. Except for express warranties made herein, all other warranties including implied warranties of merchantability and warranties of fitness for particular purpose are excluded. There are no warranties which extend beyond the description on the face hereof. Remedies for breach of express warranties herein are limited to repair or replacement of the goods. In no event shall damages for breach of any warranty include any consequential damages or exceed the cost of non-conforming goods sold.

C. LIMITATIONS

1. We do not warrant:
 - a. Tires and tubes, upholstery, pads and push-handle grips.
 - b. Damage from neglect, accident, misuse, or from improper installation or repair.
 - c. Products modified without Sunrise Medical's express written consent.
 - d. Damage from exceeding the weight limit.
2. This warranty is VOID if the original chair serial number tag is removed or altered.
3. This warranty applies in the USA only. Check with your supplier to find out if international warranties apply.
4. This warranty is not transferable and only applies to the first consumer purchase of this wheelchair through an authorized Sunrise Medical dealer.

D. WHAT WE WILL DO

Our sole liability is to repair or replace covered parts. This is the exclusive remedy for consequential damages.

E. WHAT YOU/DEALER MUST DO

1. Obtain from an Authorized Supplier, while the warranty is in effect, prior approval for return and/or repair of covered parts.
2. Return the wheelchair or part(s), freight prepaid, to Sunrise Medical at: 2842 Business Park Avenue, Fresno, CA USA 93727-1328.
3. Pay the cost of labor to repair, remove, or install parts.

F. NOTICE TO CONSUMER

1. If allowed by law, this warranty is in place of any other warranty (written or oral, express or implied, including a warranty of merchantability, or fitness for a particular purpose).
2. This warranty gives you certain legal rights. You may also have other rights that vary from state to state or province to province.

G. ADDITIONAL WARRANTY INFORMATION

For goods provided by Sunrise Medical Pty Ltd in Australia, our goods come with a guarantee by Sunrise that cannot be excluded under the Australian Consumer Law. You are entitled to a replacement or refund for a major failure and for compensation for any other reasonably foreseeable loss or damage. You are also entitled to have the goods repaired or replaced if the goods fail to be of acceptable quality and the failure does not amount to a major failure. The benefits to you given by this warranty are in addition to your other rights and remedies under a law in relation to the goods to which the warranty relates.

Record your serial number here for future reference:

Sunrise Medical • 2842 Business Park Ave. • Fresno, CA 93727 • USA
In Canada (800) 263-3390



Customer Service: 800.333.4000
www.SunriseMedical.com

©2018 Sunrise Medical (US) LLC
11.18 MK-100071 Rev. F