



QUICKIE 5R

Quickie® 5R

- with transit option without transit option

Supplier: This manual must be given to the rider of this wheelchair.

Owner's Manual

Rider: Before using this wheelchair read this entire manual and save for future reference.

Quickie® 5R

Distribuidor: Este manual debe ser entregado al pasajero de esta silla de ruedas.

Pasajero: Antes de usar esta silla de ruedas, lea este manual en su totalidad y guárdelo para futura referencia.

Manual de Instrucciones

Cada una de las sillas se envía con un manual de instrucciones en inglés. El manual en español o francés está disponible en formato PDF en nuestra página en Internet: www.SunriseMedical.com. Ingrese a la página del producto específico para descargar el manual, o comuníquese con el proveedor autorizado de Sunrise Medical.

Quickie® 5R

Au Fournisseur: Ce manuel doit être remis à l'utilisateur de ce fauteuil roulant.

À l'Usager : Veuillez lire tout le manuel et le conserver pour référence ultérieure.

Manuel d'instructions

Chaque fauteuil est livré avec un manuel d'instructions en anglais. Les versions en espagnol et en français sont à votre disposition en format PDF sur le site : www.SunriseMedical.com. Veuillez vous rendre à la page de votre produit pour télécharger le manuel dans la langue souhaitée, ou contactez un fournisseur agréé Sunrise Medical.



SUNRISE MEDICAL LISTENS

Thank you for choosing a Quickie wheelchair. We want to hear your questions or comments about this manual, the safety and reliability of your chair, and the service you receive from your Sunrise supplier. Please feel free to write or call us at the address and telephone number below:

Sunrise Medical (US) LLC
Customer Service Department
12002 Volunteer Blvd.
Mount Juliet, TN 37122, USA
(800) 333-4000

Be sure to return your warranty card, and let us know if you change your address. This will allow us to keep you up to date with information about safety, new products and options to increase your use and enjoyment of this wheelchair. If you lose your warranty card, call or write and we will gladly send you a new one.

FOR ANSWERS TO YOUR QUESTIONS

Your authorized dealer knows your wheelchair best, and can answer most of your questions about chair safety, use and maintenance. For future reference, fill in the following:

Supplier: _____

Address: _____

Telephone: _____

Serial #: _____ Date/Purchased: _____

ADDITIONAL INFORMATION YOU SHOULD KNOW

No component of this chair was made with Natural Rubber Latex.

I. INTRODUCTION.....	2	I. PUSH HANDLES (OPTIONAL).....	13
II. TABLE OF CONTENTS.....	3	J. QUICK-RELEASE AXLES.....	13
III. YOUR CHAIR AND ITS PARTS.....	4	K. REAR WHEELS.....	13
IV. NOTICE- READ BEFORE USE.....	5	L. REAR WHEEL LOCKS.....	13
A. CHOOSE THE RIGHT CHAIR & SAFETY OPTIONS.....	5	M. MODIFIED SEAT SYSTEMS.....	13
B. REVIEW THIS MANUAL OFTEN.....	5	N. SEAT AND BACK UPHOLSTERY.....	14
C. WARNINGS.....	5	O. BACKREST TENSION ADJUSTABLE.....	14
V. GENERAL WARNINGS.....	5	P. REAR SUSPENSION (OPTIONAL).....	14
A. WEIGHT LIMITS.....	5	VIII. USE AND MAINTENANCE.....	15
B. INTENDED USE.....	5	A. INTRODUCTION.....	15
C. ATTENDANTS AND CAREGIVERS.....	5	B. CRITICAL SAFETY CHECKS.....	15
D. ACCESSORIES.....	5	C. CLEANING.....	15
E. KNOW YOUR CHAIR.....	5	D. SAFETY CHECKLIST.....	15
F. REDUCE THE RISK OF AN ACCIDENT.....	6	E. TROUBLESHOOTING CHART.....	15
G. SAFETY CHECKLIST.....	6	F. TO MOUNT & REMOVE REAR WHEELS.....	16
H. CHANGES & ADJUSTMENTS.....	6	G. WHEEL LOCKS.....	16
I. ENVIRONMENTAL CONDITIONS.....	6	H. PADDED SWING-AWAY ARMRESTS (OPTION).....	17
J. TERRAIN.....	6	I. HEIGHT-ADJUSTABLE ARMRESTS (Optional).....	17
K. STREET USE.....	6	J. FLIP-UP FOOTPLATE.....	17
L. MOTOR VEHICLE SAFETY.....	6	K. BACK ANGLE PERFORMANCE.....	18
M. WHEN YOU NEED HELP.....	7	L. BACKREST TENSION ADJUSTABLE.....	18
VI. SAFETY WARNINGS: FALLS & TIP-OVERS.....	7	M. CUSHION INSTALLATION.....	19
A. CENTER OF BALANCE.....	7	N. STORAGE TIPS.....	19
B. DRESSING OR CHANGING CLOTHES.....	7	O. CHECK-OUT.....	19
C. OBSTACLES.....	7	IX. DEALER SERVICE & ADJUSTMENT.....	20
D. FRONT CASTER LIFT.....	8	A. DEALER SERVICE INTRODUCTION.....	20
E. REACHING OR LEANING.....	8	B. CRITICAL MAINTENANCE TIPS.....	20
F. MOVING BACKWARD.....	8	C. CLEANING.....	20
G. ESCALATORS.....	8	D. REAR WHEEL AXLE NUT ADJUSTMENT.....	20
H. RAMPS, SLOPES & SIDEHILLS.....	8	E. WHEEL LOCKS.....	21
I. TRANSFERS.....	9	F. XTR SUSPENSION ANTI-TIP TUBES (OPTION).....	21
J. CURBS & SINGLE STEPS.....	10	G. ARMREST RECEIVER ATTACHMENT.....	22
K. CLIMBING A CURB OR SINGLE STEP.....	10	H. PADDED SWING-AWAY ARMRESTS (OPTION).....	22
L. STAIRS.....	11	I. FOOTREST ADJUSTMENT.....	22
M. CLIMBING STAIRS.....	11	J. CASTERS.....	23
N. DESCENDING STAIRS.....	11	K. ANTI-FLUTTER KIT INSTALLATION.....	24
VII. WARNINGS: COMPONENTS & OPTIONS.....	12	L. BACK ADJUSTMENTS.....	24
A. ANTI-TIP TUBES.....	12	M. REAR AXLE ADJUSTMENTS.....	25
B. ARMRESTS.....	12	N. CENTER OF GRAVITY (CG) ADJUSTMENT.....	26
C. CUSHIONS & SLING SEATS.....	12	O. REAR WHEEL SPACING.....	27
D. OFFSET SEATING (OPTIONAL).....	12	P. SEAT SLING ADJUSTMENT.....	27
E. FASTENERS.....	12	Q. REAR SEAT HEIGHT ADJUSTMENT.....	27
F. FOOTRESTS.....	12	R. REAR AXLE PLATE SUSPENSION.....	28
G. PNEUMATIC TIRES.....	12	S. XTR SUSPENSION (OPTIONAL).....	28
H. POSITIONING BELTS (OPTIONAL).....	13	T. CHECK-OUT.....	28
		X. SUNRISE LIMITED WARRANTY.....	29



1. Backrest
2. Tire
3. Seat Sling
4. Wheel Lock
5. Foot Platform
6. Caster Fork
7. Caster Wheel
8. Caster Arm
9. Camber Tube
10. Handrim
11. Wheel Rim
12. Quick-Release Axle
13. Axle Plate
14. Folding Backrest Bracket
15. Push Handle

Note: All features may not be available with some chair setups or in conjunction with another chair feature. Please consult your authorized dealer for more information.

QUICKIE 5R

Weight

Chair weight will vary per component options

Adjustments

Caster angle, CG(Center of Gravity), rear seat height, back angle, footrest length, rear wheel spacing

Color

Quickie colors

Frame Dimensions

Frame width: Std 12" - 20" (XTR Suspension: 14" - 20")
 Seat depth: 12" - 20" (XTR Suspension: 14" - 20")

Backrest

Non-folding
 Folding Lock Down Angle Adjustable
 Height-Adjustable & angle: 11"-14", 12"-16", 16"-20"
 Fixed Height: 10"-20"
 Opt- Adjustable upholstery, vented adjustable upholstery, folding push handles

Footrest

Std- Tubular
 Opt- Tubular w/Cover, Angle Adjustable Platform Aluminum

Casters

Std-5" Low-profile Polyurethane
 Opt-5" Semi Pneumatic, Aluminum soft roll
 Opt-4" Low-profile Poly, 4" Micro Light Up Aluminum Poly, 4"x1.5" Aluminum soft Roll, 4"x 1.25 Semi Pneumatic, 3" Micro, 3" Micro Light Up, 4", 5" & 6" x 1-1/2" wide poly, 6" Poly, Frog Legs.

Armrests

Opt- Padded Swing-Away
 Opt- Single-Post Height-Adjustable

Axle Bracket

Std- Fore/Aft CG Adjustable Bracket
 Opt Camber- 0°, 3°, 6°, XTR Camber- 0°, 4°, 8°, amputee

Axles

Std- stainless steel
 Opt- quad-release axle nuts

Anti-tip tubes

Opt- Rear anti-tip tubes, Flip-up.

Standard rear wheels

Std- Lite Spoke, 5 spoke Mag

Quickie Performance wheels

Opt- Spinerge
 Opt- Ultra lightweight
 Opt - SPOX, LX Black
 Opt- Mountain
 Opt- Topolino carbon with Red or yellow spokes

Tire size

Std- 24"
 Opt- 20", 22", 25", 26"

Tire types

Std - Pneumatic
 Opt - Airless insert, Poly, Kevlar (24" only), High-pressure clinchers (24", 26" only), Mountain bike (24" only), Full Poly, Shox, Knobby V-TRAK, Schwalbe Marathon Plus,

Hand rims

Std- aluminum
 Opt- plastic-coated vertical/oblique projections, Natural Fit, Surge, and Q-Grip

Wheel locks

High-push, high-pull, ergo scissor
 Opt- compact

A. CHOOSE THE RIGHT CHAIR & SAFETY OPTIONS

Sunrise provides a choice of many wheelchair styles to meet your needs. This product is intended for single person use only. Final selection of the type of wheelchair, options and adjustments rests solely with you and your health care professional. Choosing the best chair for your unique mobility needs, will depend on such things as:

1. Your disability, strength, balance and coordination.
1. The types of hazards you must overcome in daily use (where you live and work, and other places you are likely to use your chair).
1. The need for options that will improve your positioning, safety and comfort (such as anti-tip tubes, positioning belts, or special seating systems).

B. REVIEW THIS MANUAL OFTEN

Before using this chair you, and each person who may assist you, should read this entire manual and make sure to follow all instructions. Review the warnings often, until they are second nature to you.

C. WARNINGS

The word “WARNING” refers to a hazard or unsafe practice that may cause severe injury or death to you or to other persons. The “Warnings” are in three main sections, as follows:

1. V — GENERAL WARNINGS
Here you will find a safety checklist and a summary of risks you need to be aware of before you ride this chair.
2. VI— SAFETY WARNINGS: FALLS & TIP-OVERS
Here you will learn about practices for the safe use of your chair, and how to avoid a fall or tip-over while you perform daily activities in your chair.
3. VII — WARNINGS — COMPONENTS & OPTIONS
Here you will learn about the components of your chair and options you can select for safety. Consult your authorized dealer and your health care professional to help you choose the best set-up and options for safe use.

NOTE Where they apply, you will also find “Warnings” in other sections of this manual. Heed all warnings in these sections. If you fail to do so a fall, tip-over or loss of control may occur and cause severe injury to the rider or others.

V. GENERAL WARNINGS

A. WEIGHT LIMITS

WARNING

NEVER exceed the weight limit specified by Sunrise Medical. The weight capacity provided by your manufacturer is for the combined weight of a rider and items carried using on-board storage. If you do exceed the weight limit, damage to your chair, a fall, tip-over or loss of control may occur and cause severe injury to the rider or others.

Weight Capacity

Quickie 5R - 265lbs/(120Kg).

B. INTENDED USE

The Quickie 5R wheelchair's intended use is to provide mobility to persons limited to a sitting position.

WARNING

DO NOT use this device for purposes other than what is intended by the manufacturer

1. The wheelchair is not designed for weight training and is unsafe for use as a seat while weight training. Weight training from the wheelchair substantially changes the stability of the chair and may cause tipping.
2. DO NOT stand on the frame of the wheelchair.
3. NEVER allow someone to stand on your chair or use it as a step ladder.
4. This chair is designed for a single rider only.
5. Unauthorized modifications and use of parts or accessories not supplied or approved by Sunrise Medical may change the chair structure. This will void the warranty and may cause a safety hazard. If the warning is ignored, damage to your chair, and the potential for severe injury of the person using the chair for unintended purposes can occur.

C. ATTENDANTS AND CAREGIVERS

WARNING

Before you assist a rider, be sure to read all warnings contained in this manual, and follow all instructions that apply. Be aware that after consulting a healthcare professional, you will need to learn safe and proven body mechanics to use and create assistive methods best suited to your abilities.

D. ACCESSORIES

WARNING

Unauthorized modifications or use of parts, or accessories not supplied or approved by Sunrise Medical may change the chair structure. This will void the warranty and may cause a safety hazard.

Some problems that may occur, but are not limited to:

1. Incorrect Wheels and/or tires that put the rider at risk of a fall or tip-over.
2. Adding a component to the frame, changing the structural integrity of the chair.
3. Any modification or disassembly can potentially create an unsafe situation where rider and/or attendant are put at risk.

E. KNOW YOUR CHAIR

WARNING

Every wheelchair is different. Take the time to learn the feel of this chair before you begin riding. Start slowly, with easy, smooth strokes. If you are used to a different chair, you may use too much force and tip over. If you use too much force, damage to your chair, a fall, tip-over or loss of control may occur and cause severe injury to the rider or others.

F. REDUCE THE RISK OF AN ACCIDENT

⚠ WARNING

- BEFORE you begin riding, you should be trained in the safe use of this chair by your health care professional.
- Practice bending, reaching and transfers until you know the limit of your ability. Have someone help you until you know what can cause a fall or tip-over and how to avoid doing so.
- Be aware that you must develop your own methods for safe use best suited to your level of function and ability.
- NEVER try a new maneuver on your own. Ask the advice of your health care provider to lower the risk of a fall or tip over.
- Get to know the areas where you plan to use your chair. Look for hazards and learn how to avoid them.

G. SAFETY CHECKLIST

⚠ WARNING

Before Each Use Of Your Chair:

- Make sure the chair rolls easily and that all parts work smoothly. Check for noise, vibration, or a change in ease of use. (This may indicate low tire pressure, loose fasteners, or damage to your chair).
- Inspect for any problems. Your authorized dealer can help you find and correct the problem(s).
- Check to see that both quick-release rear axles are locked. When locked, the axle button will "pop out" fully. If not locked, the wheel may come off and cause you to fall.
- If your chair has anti-tip tubes, lock them in place.

H. CHANGES & ADJUSTMENTS

⚠ WARNING

- See your healthcare professional and have them adjust seating components any time a change or adjustment needs to be made.
- Unauthorized modifications or use of parts not supplied or approved by Sunrise may change the chair structure. This will void the warranty and may cause a safety hazard.

If you fail to heed these warnings, damage to your chair, a fall, tip-over or loss of control may occur and cause severe injury to the rider or others.

I. ENVIRONMENTAL CONDITIONS

⚠ WARNING



- Use extra care if you must ride your chair on a wet or slick surface. If you are in doubt, ask for help.
- Contact with water or excess moisture may cause your chair to rust or corrode. Avoid all extreme weather situations if possible.
 - Do not use your chair in a shower, pool or other body of water. The chair tubing and parts are not water-tight and may rust or corrode from the inside.
 - Avoid excess moisture (for example, do not leave your chair in a damp bathroom while taking a shower).
 - Dry your chair as soon as you can if it gets wet, or if you use water to clean it.

If you fail to heed these warnings, damage to your chair, a fall, tip-over or loss of control may occur and cause severe injury to the rider or others.

J. TERRAIN

⚠ WARNING

- Based on ANSI/RESNA testing, Sunrise Medical recommends the use of a caster wheel with a minimum diameter of 5", if the wheelchair will be overcoming obstacles up to 1/2" on a regular basis.
- Your chair is designed for use on firm, even surfaces such as concrete, asphalt, indoor flooring, and carpets.
- Do not operate your chair in sand, loose soil, or over rocky terrain.
- If you use your chair on terrain that is rougher than described above there is a danger that screws and bolts will loosen prematurely, and that damage to wheels or axles could put the rider at risk of a fall, tip-over, or loss of control.

If you fail to heed these warnings, damage to your chair, a fall, tip-over or loss of control may occur and cause severe injury to the rider or others.

K. STREET USE

⚠ WARNING

- This product is not intended for street use.
- Avoid streets whenever possible.
- Obey and follow all legal pedestrian pathways, and laws that apply to pedestrians.
- Be alert to the danger of motor vehicles in parking lots, or if you must cross a road.

If you fail to heed this warning, damage to your chair, and a possible collision may occur and cause severe injury to the rider or others.

L. MOTOR VEHICLE SAFETY 1 2

If possible and feasible, the rider should transfer to the Original Equipment Manufacturer vehicle seat and use the OEM vehicle restraint.

Sunrise Medical does provide a WC-19 Wheelchair Tie-Down and Occupant Restraint System, otherwise called a Transit Option. To identify whether your wheelchair has been manufactured with the Transit Option installed, look for four points of securement. Two Front points (A), and two rear points (B). These points are recognized by the securement point decal which can be found on or near the securement points.

If your wheelchair is equipped with the Transit Option, please review the Transit Securement supplement that was provided with the wheelchair for additional information and instructions. You can request a copy from your authorized dealer, or call Sunrise medical at 1-800-333-4000 if you don't have it.

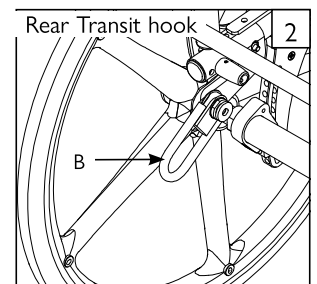
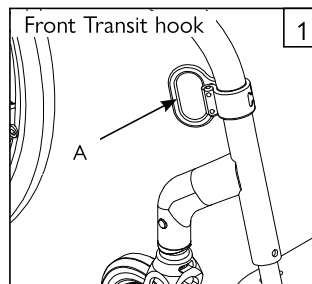

Look for this symbol on your wheelchair. It indicates wheelchair securement points which conform to ANSI/RESNA (1998) V.1 - Section 19 and/or ANSI/RESNA (2012) V.4 WC-19. For more Transit related information, see the "Transit Securement Supplement" included with your chair.

⚠ WARNING

If your chair is NOT equipped with the Transit Option:

1. NEVER let anyone sit in this chair while in a moving vehicle.
 - a. ALWAYS move the rider to an approved vehicle seat.
 - b. ALWAYS secure the rider with proper motor vehicle restraints.
2. In an accident or sudden stop the rider may be thrown from the chair. Wheelchair seat belts will not prevent this, and further injury may result from the belts or straps.
3. NEVER transport this chair in the front seat of a vehicle. It may shift and interfere with the driver.
4. ALWAYS secure this chair so that it cannot roll or shift.
5. Do not use any chair that has been involved in a motor vehicle accident. The frame and/or components may have been changed due to the accident. Such items could be, but are not limited to: bent, loosened, and/or broken components that were subjected to an impact.

Failure to heed these warnings puts you and others who may assist you at a high risk of injury.

M. WHEN YOU NEED HELP**⚠ WARNING**

For The Rider: Make sure that each person who helps you reads and follows all warnings and instructions that apply.

For Attendants:

1. Work with the rider's doctor, nurse or therapist to learn safe methods best suited to your abilities and those of the rider.
2. Tell the rider what you plan to do, and explain what you expect the rider to do. This will put the rider at ease and reduce the risk of an accident.
3. Make sure the chair has push handles. They provide secure points for you to hold the rear of the chair to prevent a fall or tip-over. Check to make sure push handle grips will not rotate or slip off.
4. To prevent injury to your back, use good posture and proper body mechanics. When you lift or support the rider or tilt the chair, bend your knees slightly and keep your back as upright and straight as you can.
5. Remind the rider to lean back when you tilt the chair backward.
6. When you descend a curb or single step, slowly lower the chair in one easy movement. Do not let the chair drop the last few inches to the ground. This may damage the chair or injure the rider.
7. To avoid tripping, unlock and rotate anti-tip tubes up, out of the way.
8. Whenever you aren't attending the wheelchair, ALWAYS use the wheel-lock to secure the rear wheels, and lock the anti-tip tubes in place.

If you fail to ask for help when in doubt, you run a high risk of a fall, tip-over or loss of control that may occur and cause severe injury to the rider or others.

VI. SAFETY WARNINGS: FALLS & TIP-OVERS

A. CENTER OF BALANCE**⚠ WARNING**

The point where this chair will tip forward, back or to the side depends on its center of balance and stability. How your chair is set up, the options you select and the changes you make may affect the risk of a fall or tip-over.

1. The Most Important Adjustment Is:

The position of the rear wheels. The more you move the rear wheels forward, the more likely your chair will tip over backward.
2. The Center Of Balance Is Also Affected By:
 - a. A change in the set-up of your chair, including:
 - The distance between the rear wheels.
 - The amount of rear wheel camber.
 - The seat height and seat angle.
 - Backrest angle.
 - b. A change in your body position, posture or weight distribution.
 - c. Riding your chair on a ramp or slope.
 - d. A back pack or other options and the amount of added weight.
3. To Reduce The Risk Of An Accident:
 - a. Consult your healthcare professional to find out what axle and caster position is best for you.
 - b. Consult your authorized dealer BEFORE you modify or adjust this chair. Be aware that you may need to make other changes to correct the center of balance.
 - c. Have someone help you until you know the balance points of your chair and how to avoid a tip-over.
 - d. Use anti-tip tubes.

If you fail to heed these warnings, you are at a high risk of a fall, tip-over or loss of control that could cause severe injury to the rider or others.

B. DRESSING OR CHANGING CLOTHES**⚠ WARNING**

Your weight may shift if you dress or change clothes while seated in

this chair. To reduce the risk of a fall or tip-over:

1. Rotate the front casters until they are as far forward as possible. This makes the chair more stable.
2. Lock anti-tip tubes in place. (If your chair does not have anti-tip tubes, back it up against a wall and lock both rear wheels).

If you fail to heed this warning, damage to your chair, a fall, tip-over or loss of control may occur and cause severe injury to the rider or others.

C. OBSTACLES**⚠ WARNING**

Riding over curbs or obstacles can cause tipping and serious bodily harm. If you have any doubt that you can safely cross any curb or obstacle, ALWAYS ASK FOR HELP. Be aware of your riding skills and personal limitations. Develop new skills only with the help of a companion.

To avoid the risk of traversing obstacles:

1. Keep a lookout for danger – scan the area well ahead of your chair as you ride.
2. Make sure the floor areas where you live and work are level and free of obstructions.
3. Remove or cover threshold strips between rooms.
4. Install a ramp at entry or exit doors. Make sure there is not a drop off at the bottom of the ramp.
5. To Help Correct Your Center Of Balance:
 - a. Lean your upper body FORWARD slightly as you go UP over an obstacle.
 - b. Press your upper body BACKWARD as you go DOWN from a higher to a lower level.
6. If your chair has anti-tip tubes, do not go over an obstacle without help.
7. Keep both of your hands on the handrims as you go over an obstacle.
8. Never push or pull on an object (such as furniture or a door-jamb) to propel your chair.

If you fail to heed these warnings, damage to your chair, a fall, tip-over or loss of control may occur and cause severe injury to the rider or others.

D. FRONT CASTER LIFT**⚠ WARNING**

Front caster lift can occur when the front wheels, ordinarily in contact with the ground, are either intentionally, or unintentionally caused to lift from the ground while the rear wheels remain in contact. Pitch control (partial or full) should NEVER be attempted without consulting your healthcare professional and making sure that anti-tips are installed.

If you fail to heed this warning, you are at a high risk of damage to your chair, a fall, tip-over or loss of control that may occur and cause severe injury to the rider or others.

E. REACHING OR LEANING**⚠ WARNING**

If you reach or lean it will affect the center of balance of your chair. This may cause you to fall or tip over. When in doubt, ask for help or use a device to extend your reach.

1. **NEVER** reach or lean if you must shift your weight sideways or rise up off the seat.
2. **NEVER** reach or lean if you must move forward in your seat to do so. Always keep your buttocks in contact with the backrest.
3. **NEVER** reach with both hands (you may not be able to catch yourself to prevent a fall if the chair tips).
4. **NEVER** reach or lean to the rear unless your chair has anti-tip tubes locked in place.
5. **DO NOT** reach or lean over the top of the seat back. This may damage one or both backrest tubes and cause you to fall.
6. If You Must Reach Or Lean:
 - a. Do not lock the rear wheels. This creates a tip point and makes a fall or tip-over more likely.
 - b. Do not put pressure on the footrests.
 - c. Move your chair as close as you can to the object you wish to reach.
 - d. Do not try to pick up an object from the floor by reaching down between your knees. You are less likely to tip if you reach to the side of your chair.
 - e. Rotate the front casters until they are as far forward as possible. This makes the chair more stable.
 - f. Firmly grasp a rear wheel or an armrest with one hand. This will help to prevent a fall if the chair tips.

If you fail to heed these warnings, damage to your chair, a fall, tip-over or loss of control may occur and cause severe injury to the rider or others.

F. MOVING BACKWARD**⚠ WARNING**

Use extra care when you move your chair backward. Your chair is most stable when you propel yourself forward. You may lose control or tip over if one of the rear wheels hits an object and stops rolling.

1. Propel your chair slowly and smoothly.
2. If your chair has anti-tip tubes, make sure to lock them in place.
3. Stop often and check to be sure your path is clear.

If you fail to heed this warning, you are at a high risk of damage to your chair, a fall, tip-over or loss of control that may occur and cause severe injury to the rider or others.

G. ESCALATORS**⚠ WARNING**

NEVER use this chair on an escalator, even with an attendant. If you do, a fall or tip-over is likely.

H. RAMPS, SLOPES & SIDEHILLS

3 4 5 6

⚠ WARNING

Whenever possible, avoid riding on a slope, which includes a ramp or sidehill. This will change the center of balance of your chair. Your chair is less stable and more difficult to maneuver when it is at an angle. When moving up a hill, anti-tip tubes may not prevent a fall or tip-over. Always ask for help when riding on slopes.

1. **Do not** use your chair on a slope steeper than 10°.
2. Avoid Sidehills. Do not use your chair on a sidehill with a slope steeper than 6°.
3. **Always** go straight up or straight down a slope. Do not “cut the corner” on a slope or ramp.
4. **Do not** turn or change direction on a slope.
5. **Do not** stop on a steep slope. If you stop, you may lose control of your chair.
6. **NEVER** use rear wheel locks to try to slow or stop your chair. This is likely to cause your chair to veer out of control.
7. **ALWAYS** be aware of:
 - a. Wet or slippery surfaces.
 - b. A change in grade on a slope (or a lip, bump or depression). These may cause a fall or tip-over.
 - c. A drop-off at the bottom of a slope or ramp. A drop-off as small as 3/4 inch can stop a front caster and cause the chair to tip forward.
8. To Reduce The Risk Of A Fall Or Tip-Over:
 - a. Lean or press your body UPHILL. This will help adjust for the change in the center of balance caused by the slope or sidehill.
 - b. Keep pressure on the handrims to control your speed on a down slope. If you go too fast you may lose control.
 - c. Ask for help any time you are in doubt.
9. Ramps at home & work— For your safety, ramps at home and work must meet all legal requirements for your area:
 - a. Avoid a drop off. You may need a section at the top or bottom to smooth out the transition.
 - b. Stay in the center of the ramp and control your speed.
10. When you have to use a ramp, always stay in the CENTER of the ramp. Make sure the ramp is wide enough so that you have no risk of going off the edge.

If you fail to heed these warnings, damage to your chair, a fall, tip-over or loss of control may occur and cause severe injury to the rider or others.

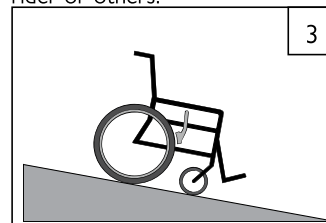

- If you need to go down a hill:
- a. The downslope should be less than 10°
 - b. GO SLOWLY
 - c. ALWAYS go straight down
 - d. ALWAYS control your speed
 - e. DO NOT Turn on the hill.

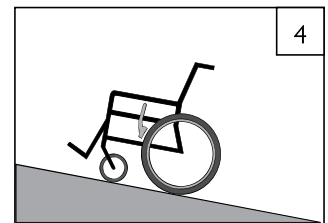

- If you need to go up a hill:
- a. The upslope should be less than 10°
 - b. ALWAYS go straight up
 - c. NEVER stop on the upslope
 - d. NEVER turn on a hill.
 - e. ALWAYS lean forward.

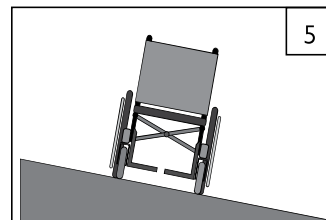

- If you need to traverse a sidehill:
- a. The sidehill must be less than 6° or you risk a tip-over
 - b. DON'T STOP
 - c. ALWAYS go straight down
 - d. DO NOT turn on the hill.

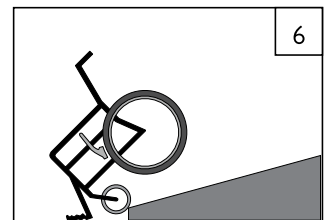

- If you need to traverse a ramp:
- a. GO SLOWLY
 - b. Watch out for drop-offs.
 - c. ALWAYS go straight down.
 - d. Stay centered on the ramp.
 - e. ALWAYS lean forward.

I. TRANSFERS 7 8**⚠ WARNING**

It is dangerous to transfer on your own. It requires good balance and agility. Be aware that there is a point during every transfer when the wheelchair seat is not below you. To avoid a fall:

1. Work with your health care advisor to learn safe methods for transfers.
 - a. Learn how to position your body and how to support yourself during a transfer.
 - b. Have someone help you until you learn safe transfer methods.
2. Lock the rear wheels before you transfer.
3. Be aware that the chair can still slide and/or tip. The wheel lock keeps the rear wheels from rolling while you are performing the transfer.
4. Make sure that the pneumatic tires are properly inflated. Low tire pressure may allow the rear wheel locks to slip. (see table in Section H "Pneumatic Tires")
5. Move your chair as close as you can to the seat you are transferring to. If possible, use a transfer board.
6. Rotate the front casters until they are as far forward as possible.
7. If you can, remove the footrests, or swing them out of the way.
 - a. Make sure your feet do not catch in the space between the footrests.
 - b. Avoid putting weight on the footrests as this may cause the chair to tip.
8. Make sure armrests are removed, or out of the way and do not interfere with the transfer.
9. Transfer as far back onto the seat surface as you can. This will reduce the risk that the chair will tip or move away from you.

Optimum Transfer position

**Before transferring:**

Flip-back, or Remove the armrests out of the way.

Swing, or remove the footrests out of the way.

Make sure the wheel lock is set.

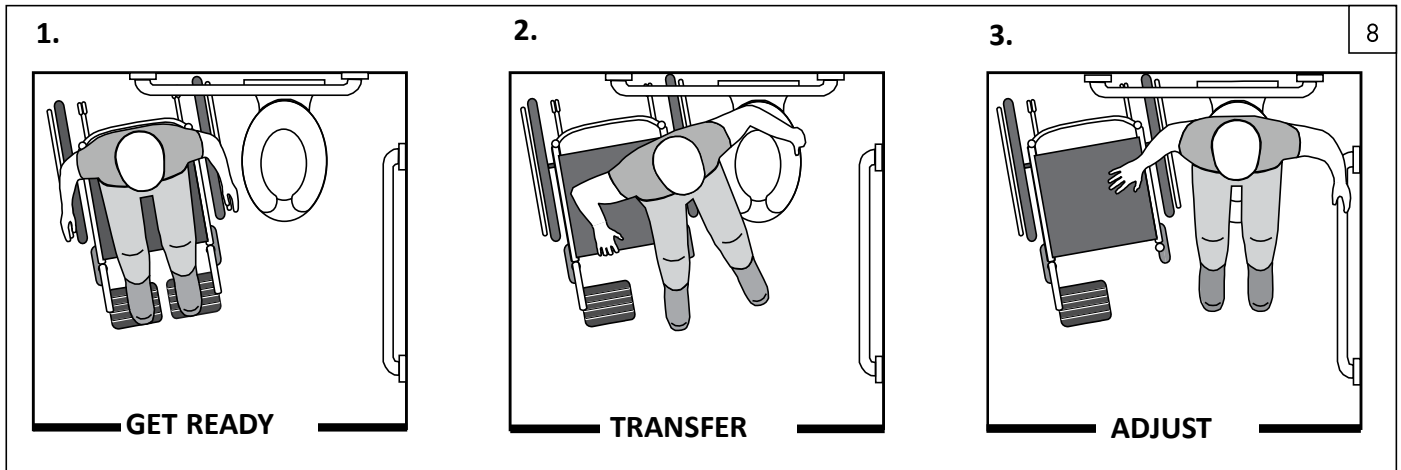

J. CURBS & SINGLE STEPS 9**⚠ WARNING**

Before riding over curbs, and negotiating even a single step, **ALWAYS** ask for assistance first. Curbs and steps can cause tipping and serious bodily harm. When in doubt as to your ability to avoid, or traverse any obstacle, always ask for help. Be aware of your riding skills and personal limitations. Develop new skills only with the help of a companion.

For Attendant: Each person who assists the rider with curbs and steps should read and follow all instructions and warnings pertaining to attendants and caregivers.

1. Do not try to climb a high curb or step (more than 4 inches high) **UNLESS** you have help. Doing so may cause your chair to exceed its balance point and tip over.
2. Go straight up and straight down a curb or step. If you climb or descend at an angle, a fall or tip-over is likely.
3. Be aware that the impact of dropping down from a curb or step can damage your chair or loosen fasteners.

If you fail to heed these warnings, damage to your chair, a fall, tip-over or loss of control may occur and can possibly cause severe injury to the rider or others.

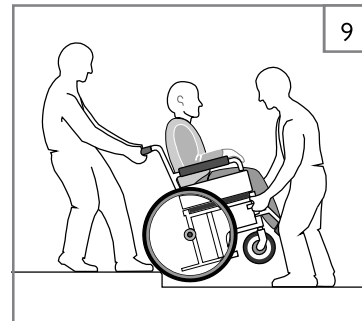
**K. CLIMBING A CURB OR SINGLE STEP** 9**⚠ WARNING**

For Attendant: Follow these steps to help the rider climb a curb or single step going **BACKWARD**:

1. Stay behind the chair.
2. Continue backward until the rear wheels contact the face of the curb or step. Lift and roll the rear wheels to the top of the curb.
3. Pull the chair backwards until the caster wheels have cleared the edge of the curb and return the chair to a rolling position.

If you fail to heed these warnings, damage to your chair, a fall, tip-over or loss of control may occur and cause severe injury to the rider or others.

L. DESCENDING A CURB OR SINGLE STEP 9**⚠ WARNING**

For Attendant: Follow these steps to help a rider descend a curb or single step going **FORWARD**:

1. Stay at the rear of the chair.
2. Several feet before you reach the edge of the curb or step, tip the chair slightly and pull it backward.
3. When the chair is at its balance point, carefully step forwards until the rear wheels reach the edge of the curb or step. Then allow the rear wheels to slowly roll down onto the lower level.
4. Push the chair forward until you are standing on the lower level.
5. When the rear wheels are safely on the lower level, tilt the chair back to its balance point.

If you fail to heed these warnings, damage to your chair, a fall, tip-over or loss of control may occur and cause severe injury to the rider or others.

M. STAIRS 10**⚠ WARNING**

1. **NEVER** use this chair on stairs UNLESS you have someone to help you. Doing so is likely to cause a fall or tip-over.
 2. Negotiating stairs with a wheelchair always requires at least two attendants for safety.
- If you fail to heed these warnings damage to your chair, a fall, tip-over or loss of control may occur and cause severe injury to the rider or others.

N. CLIMBING STAIRS 10**⚠ WARNING**

1. Use at least two attendants to move a chair and rider up stairs.
 2. Move the chair and rider **BACKWARD** up the stairs.
 3. The person at the rear is in control. He or she tilts the chair back to its balance point.
 4. A second attendant at the front firmly grasps a non-detachable part of the front frame and lifts the chair up and over one stair at a time.
 5. The attendants move to the next stair up. Repeat for each stair until you reach the landing.
- If you fail to heed these warnings, damage to your chair, a fall, tip-over or loss of control may occur and cause severe injury to the rider or others.

O. DESCENDING STAIRS 10**⚠ WARNING**

1. Use at least two attendants to move a chair and rider down stairs.
 2. Move the chair and rider **FORWARD** down the stairs.
 3. The person at the rear is in control. He or she tilts the chair to the balance point of the rear wheels and rolls it to the edge of the top step.
 4. A second attendant stands on the third step from the top and grasps the chair frame. He or she lowers the chair one step at a time by letting the rear wheels roll over the stair edge.
 5. The attendants move to the next stair down. Repeat for each stair, until you reach the landing.
- If you fail to heed these warnings damage to your chair, a fall, tip-over or loss of control may occur and cause severe injury to the rider or others.

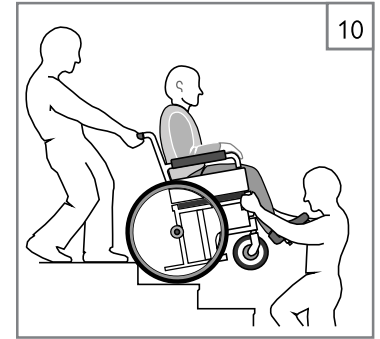

A. ANTI-TIP TUBES

⚠ WARNING

Anti-tip tubes can help keep your chair from tipping over backward in normal conditions.

1. Sunrise recommends the use of anti-tip tubes.
2. When locked in place (in the “down” position) anti-tip tubes should be BETWEEN 1 1/2 to 2 inches (3.75 to 5cm) off the ground.
 - a. If set higher than 2 inches (5cm), they may not prevent a tip-over.
 - b. If set lower than 1 1/2 inches, (3.75cm) they may “hang up” on obstacles and cause a fall or tip over.
3. If you have to climb or descend a curb, or overcome an obstacle it may be necessary to have an attendant make sure the anti-tip tubes are rotated up, and out of the way, so that the chair and rider do not get stuck and/or become unstable.

If you fail to heed these warnings damage to your chair, a fall, tip-over or loss of control may occur and cause severe injury to the rider or others.

B. ARMRESTS

⚠ WARNING

Armrests detach and will not bear the weight of this chair.

1. NEVER lift this chair by its armrests. They may come loose or break.
2. Lift this chair only by non-detachable parts of the main frame.

If you fail to heed these warnings damage to your chair, a fall, tip-over or loss of control may occur and cause severe injury to the rider or others.

C. CUSHIONS & SLING SEATS

⚠ WARNING

1. Quickie sling seats and standard foam cushions are not designed for the relief of pressure.
2. If you suffer from pressure sores, or if you are at risk that they will occur, you may need a special seat system or a device to control your posture. Consult your doctor, nurse or therapist to find out if you need such a device for your well-being.
3. Seat slings are not intended to be used as a direct seating surface. A cushion or other seating surface should be placed on the sling before use.

If you fail to heed these warnings damage to your chair, a fall, tip-over or loss of control may occur and cause severe injury to the rider or others.

D. OFFSET SEATING (Optional)

⚠ WARNING

1. A fore/aft change in the backrest position will affect the center of balance of your chair.
2. Only use this option when installing a forward offset mounted seating solution, not using the standard back sling.
3. Each time you adjust or modify the backrest plane location, the change may make it easier to tip backwards. Use anti-tips.

E. FASTENERS

⚠ WARNING

Many of the screws, bolts and nuts on this chair are special high-strength fasteners. Use of improper fasteners may cause your chair to fail.

1. **ONLY** use fasteners provided by an authorized dealer (or ones of the same type and strength, as indicated by the markings on the heads).
2. Over- or under-tightened fasteners may fail or cause damage to chair parts.
3. If bolts or screws become loose, tighten them as soon as you can.

F. FOOTRESTS

⚠ WARNING

1. At the lowest point, footrests should be AT LEAST 2 inches off the ground. If set too LOW, they may “hang up” on obstacles you can expect to find in normal use. This may cause the chair to stop suddenly and tip forward.
2. To Avoid A Trip Or Fall When You Transfer:
 - a. Make sure your feet do not “hang up” or get caught in the space between the footrests.
 - b. Avoid putting weight on the footrests, as the chair may tip forward.
 - c. Footrests should be swung out of the way or removed whenever entering or exiting the wheelchair.
3. **NEVER** lift this chair by the footrests. Footrests detach and will not bear the weight of this chair. Lift this chair only by non-detachable parts of the main frame.
4. Never use the footrests of the chair to open doors, this may cause them to fail prematurely, and create an unsafe situation.

If you fail to heed these warnings damage to your chair, a fall, tip-over or loss of control may occur and cause severe injury to the rider or others.

G. PNEUMATIC TIRES

⚠ WARNING

Proper inflation extends the life of your tires and makes your chair easier to use.

1. Do not use this chair if any of the tires are under- or over-inflated. Check weekly for proper inflation level, as listed on the tire sidewall.
2. Low pressure in a rear tire may cause the wheel lock on that side to slip and allow the wheel to turn when you do not expect it.
3. Low pressure in any of the tires may cause the chair to veer to one side and result in a loss of control.
4. Over-inflated tires may burst.

If you fail to heed these warnings damage to your chair, a fall, tip-over or loss of control may occur and cause severe injury to the rider or others.

Tires	Q5R	Recommended Pressure or Pressure Range	
		kPa	PSI
Pneumatic (20-in)	x	448	65
Pneumatic (22-in)	x	448	65
Pneumatic (24-in)	x	517	75
Pneumatic (26-in)	x	448	65
High Pressure Clincher (22-in)	x	690	100
High Pressure Clincher (24-in)	x	758	110
High Pressure Clincher (25-in)	x	758	110
High Pressure Clincher (26-in)	x	758	110
Knobby V-Track (24-in)	x	448	65
Schwalbe Marathon (24-in)	x	586-1000	85-145
Schwalbe Marathon (25-in)	x	586-1000	85-145
Schwalbe Marathon (26-in)	x	586-1000	85-145

H. POSITIONING BELTS (Optional)**⚠ WARNING**

The positioning belt is predominately used to support your posture. It can also be used to limit slipping and/or sliding that you might experience when the chair is in motion. The positioning belt is not a transit rated safety belt and should not be used in the place of a seat belt while being transported in a motor vehicle. Improper use of Positioning belts may cause severe injury or death. If you use a positioning belt, be sure to follow the recommendations in this section:

1. Make sure the rider does not slide down in the wheelchair seat. If this occurs, the rider may suffer chest compression or suffocate due to pressure from the belts.
2. The belts must be snug, but must not be so tight that they interfere with breathing. You should be able to slide your open hand, flat, between the belt and the rider.
3. A pelvic wedge or a similar device can help keep the rider from sliding down in the seat. Consult with the rider's doctor, nurse or therapist to find out if the rider needs such a device.
4. Use positioning belts only with a rider who can cooperate. Make sure the rider can easily remove the belts in an emergency.
5. **NEVER** use positioning belts
 - a. As a patient restraint. A restraint requires a doctor's order.
 - b. On a rider who is comatose or agitated.
 - c. As a motor vehicle restraint. In an accident or sudden stop the rider may be thrown from the chair. Wheelchair positioning belts will not prevent this, and further injury may result from the belts or straps.

If you fail to heed these warnings, damage to your chair, a fall, tip-over or loss of control may occur and cause severe injury to the rider or others.

I. PUSH HANDLES (Optional)**⚠ WARNING**

When you have an attendant, make sure that this chair has push handles.

1. Push handles provide secure points for an attendant to hold the rear of this chair, to prevent a fall or tip-over.
2. Check to make sure push handle grips will not rotate or slip off.

J. QUICK-RELEASE AXLES**⚠ WARNING**

1. Do not use this chair **UNLESS** you are sure that both quick-release rear axles are locked.
2. An axle is not locked until the quick-release button pops out fully.
3. An unlocked axle may come off during use, resulting in a fall, tip-over or loss of control and cause severe injury to the rider or others.
 - Quick-Release Axles should be periodically cleaned and inspected for function and signs of wear or bending. Replace as necessary.

If you fail to heed these warnings damage to your chair, a fall, tip-over or loss of control may occur and cause severe injury to the rider or others.

K. REAR WHEELS**⚠ WARNING**

A change in set-up of the rear wheels will affect the center of balance of your chair.

1. The farther you move the rear axles **FORWARD**, the more likely it is that your chair will tip over backward.
2. Consult your healthcare professional to find the best rear axle set-up for your chair. Do not change the set-up **UNLESS** you consult your healthcare professional first.
3. Adjust the rear wheel locks after you make any change to the rear axles.
 - a. If you fail to do so, the wheel locks may not work.
 - b. Make sure lock arms embed in the tires at least 1/8 inch (3mm) when locked.

If you fail to heed these warnings, damage to your chair, a fall, tip-over or loss of control may occur and cause severe injury to the rider or others.

L. REAR WHEEL LOCKS**⚠ WARNING**

Rear wheel locks are **NOT** designed to slow or stop a moving wheelchair. Use them only to keep the rear wheels from rolling when your chair is at a complete stop.

1. **NEVER** use rear wheel locks to try to slow or stop your chair when it is moving. Doing so may cause a fall or tip-over.
2. To keep the rear wheels from rolling, always set both rear wheel locks when you transfer to or from your chair.
3. Low pressure in a rear tire may cause the wheel lock on that side to slip and may allow the wheel to turn when you do not expect it.
4. Make sure lock arms embed in tires at least 1/8 inch (3mm) when locked. If you fail to do so, the locks may not work.

If you fail to heed these warnings, damage to your chair, a fall, tip-over or loss of control may occur and cause severe injury to the rider or others.

M. MODIFIED SEAT SYSTEMS**⚠ WARNING**

Use of a seat system not approved by Sunrise may alter the center of balance of this chair. This may cause the chair to tip over.

1. Do not change the seat system of your chair **UNLESS** you consult your authorized dealer first.
2. Use of a seating system not approved by Sunrise may affect or interfere with other parts of the chair.
3. Use of a seating system not provided by Sunrise is prohibited for transit use.

If you fail to heed these warnings, damage to your chair, a fall, tip-over or loss of control may occur and cause severe injury to the rider or others.

N. SEAT AND BACK UPHOLSTERY** WARNING**

1. Replace worn or torn fabric of seat and seat back as soon as you can. If you fail to do so, the seat or seat back may fail.
2. Sling fabric will weaken with age and use. Look for fraying, thin spots, or stretching of fabrics especially at edges and seams.
3. "Dropping down" into your chair will weaken fabric and result in the need to inspect and replace the seat more often.
4. Be aware that laundering or excess moisture will reduce the flame retardation qualities of the fabric.
5. If Tension Adjustment upholstery is present, loosen straps or remove upholstery prior to folding or unfolding the chair

If you fail to heed these warnings, damage to your chair, a fall, tip-over or loss of control may occur and cause severe injury to the rider or others.

O. BACKREST TENSION ADJUSTABLE

The Tension Adjustable Backrest is a versatile back intended to replace standard wheelchair back upholstery. It is designed to provide simple, comfortable and effective support to help maximize function and increase seating tolerance. In addition, it is lightweight, durable, and easy to use.

Sunrise Medical recommends that a healthcare professional such as a doctor or therapist experienced in seating and positioning be consulted to determine if the Backrest Tension Adjustable is appropriate. Backs should only be installed by an authorized Sunrise Medical supplier.

Maximum user weight 265 lbs. (120 kg)

 WARNING

Installing a back support on a wheelchair may affect the center of gravity of the wheelchair and may cause the wheelchair to tip backwards potentially resulting in injury. Always assess for the potential need for anti-tippers to be added to the wheelchair to help increase the stability.

 WARNING

Do not use the Backrest Tension Adjustable to push or lift the wheelchair. Improper use may cause the back to unexpectedly detach from the wheelchair.

If you fail to heed these warnings damage to your chair, a fall, tip-over or loss of control may occur and cause severe injury to the rider or others.

P. REAR SUSPENSION (Optional)** WARNING**

When replacing the suspension bushings, always use genuine Sunrise parts. Use of non-Sunrise replacement parts voids the warranty and could cause structural failure.

If you fail to heed these warnings, damage to your chair, a fall, tip-over or loss of control may occur and cause severe injury to the rider or others.

⚠ WARNING

The owner of this chair is responsible for making sure that it has been set up and adjusted by a trained service professional under the advice of a healthcare professional. The chair may require periodic safety and function checks or certain in-use adjustments that can be performed by the owner, caregiver or authorized dealer if desired. Always use parts and/or accessories that have been recommended or approved by Sunrise Medical when servicing this chair.

A. INTRODUCTION

1. Proper maintenance will improve performance and extend the useful life of your chair.
2. Clean your chair regularly. This will help you find loose or worn parts and make your chair easier to use. You will need a mild detergent solution and plenty of cleaning rags.
3. If discovered, have loose, worn, bent or damaged parts replaced **before using the chair.**
4. To protect your investment, have all major maintenance and repair work done by your authorized dealer.
5. **Inspect and maintain this chair strictly per the safety checklist.**
6. **If you detect a problem, make sure to order parts, or have service, and repair work done at your authorized dealer before use.**
7. **At least once per year, have a complete inspection, safety check, and service of your chair made by an authorized dealer.**

B. CRITICAL SAFETY CHECKS

1. Tire Air Pressure:

Check air pressure in pneumatic tires at least ONCE PER WEEK. The wheel locks will not grip properly if you fail to maintain the air pressure shown on tire sidewall.

2. Axles & Axle Sleeves:

When checking axles and axle sleeves every six months, make sure they are clean and tight. Loose sleeves will damage the axle plate and will affect performance.

3. Camber Tubes and Camber Plugs

Inspect the camber tubes and plugs every 6 months ensuring that all fasteners are tight and that no parts have moved from their preset positions.

C. CLEANING

1. Paint Finish

- a. Clean the painted surfaces with mild soap or detergent at least once a month.
- b. Protect the paint with a coat of non-abrasive auto wax every three months.

2. Axles and Moving Parts

- a. Clean around axles and moving parts WEEKLY with a slightly damp (not wet) cloth.
- b. Wipe off or blow away any fluff, dust or dirt on axles or moving parts.

3. Upholstery

- a. Hand-wash (machine washing may damage fabric).
- b. Drip-dry only. DO NOT machine dry as heat will damage fabric.

4. Basic Maintenance Materials available at local store

- a. Tire pump
- b. Tire pressure gauge
- c. Clean rags or cotton cloth.
- d. Teflon-based lubricant
- e. Mild detergent.

NOTE – You do not need to grease or oil the chair.

D. SAFETY CHECKLIST

Weekly	3 Months	6 Months	Annually	Safety & Function Check
<input checked="" type="checkbox"/>				Tire inflation level
<input checked="" type="checkbox"/>				Wheel locks
	<input checked="" type="checkbox"/>			Visually check for loose hardware
		<input checked="" type="checkbox"/>		Armrests
		<input checked="" type="checkbox"/>		Axle and axle sleeves
	<input checked="" type="checkbox"/>			Quick-release axles
	<input checked="" type="checkbox"/>			Wheels, tires and spokes
	<input checked="" type="checkbox"/>			Casters
	<input checked="" type="checkbox"/>			Anti-tip tubes
		<input checked="" type="checkbox"/>		Frame, Camber tubes, and Crossbrace
	<input checked="" type="checkbox"/>			Upholstery
			<input checked="" type="checkbox"/>	Service by Authorized Dealer

NOTE - The user or caregiver should perform these weekly and monthly checks to maintain the safety of their chair. If an item is not working properly, please contact your authorized dealer.

E. TROUBLESHOOTING CHART

Symptom							Solution
	Left turn in chair	Right turn in chair	Looseness in chair	Sluggish turning	Squeaks and rattles	Caster flutter	
<input checked="" type="checkbox"/>	<input checked="" type="checkbox"/>	<input checked="" type="checkbox"/>	<input checked="" type="checkbox"/>				Make sure tire pressure is correct and equal in both rear tires and front caster tires, if pneumatic.
		<input checked="" type="checkbox"/>	<input checked="" type="checkbox"/>	<input checked="" type="checkbox"/>	<input checked="" type="checkbox"/>		Make sure all nuts and bolts are tight.
		<input checked="" type="checkbox"/>		<input checked="" type="checkbox"/>			Make sure all spokes and nipples are tight on radial spoke wheels.
					<input checked="" type="checkbox"/>		Use Tri-Flow Lubricant (Teflon®-based) between frame connections and parts.
<input checked="" type="checkbox"/>	<input checked="" type="checkbox"/>		<input checked="" type="checkbox"/>			<input checked="" type="checkbox"/>	Check for proper caster fork adjustment. See instructions for caster fork adjustment.

F. TO MOUNT & REMOVE REAR WHEELS 11 12

The rear wheel axle (B) attaches the rear wheel through to the camber plug (C). When the detent balls (D) engage into the camber plug the rear wheel effectively becomes locked onto the chair. Pushing the quick-release button (A) disengages the detent balls and allows mounting, or removal of the axle and wheel assembly.

⚠ WARNING

Do not use this chair UNLESS you are sure both quick-release axles are locked. An unlocked axle may come off during use and cause a fall. The detent ball (D) must feed all the way through the axle sleeve for the axle and wheel to lock. Be sure to check for a positive lock by trying to pull the axle and wheel out of the camber plug/axle sleeve. If the axle does not positively engage make sure to have your dealer adjust it.

NOTE – Setup for this step should include putting the wheelchair on a workbench or table to make the process easier.

1. To Install the Wheel

- a. Depress quick-release button (A) fully.
- b. Insert axle (B) through hub or rear wheel.
- c. Keep button (A) depressed as you slide axle (B) into camber plug (C).
- d. Release button to lock axle in the camber plug. The axle should be locked.
- e. Repeat these steps for the other side of your wheelchair.

2. To Remove the Wheel

- a. Depress quick-release button (A) fully.
- b. Remove wheel by sliding axle (B) out of camber plug (C)
- c. Repeat steps on the other side of your wheelchair.

G. WHEEL LOCKS 13**⚠ WARNING**

Wheel locks are installed at Sunrise and should be adjusted by your qualified service person. Inspect wheel locks weekly per the maintenance chart. Do not use your chair UNLESS you are sure both wheel-locks can fully engage. A wheel lock that is not correctly adjusted may allow your chair to roll, or turn unexpectedly. Wheel locks must be adjusted after making sure the tires have the correct air pressure. When fully engaged, the arm should be imbedded into the tire at least 1/8" (3mm) (E) to be effective. If you find the wheel locks have slipped or are not working correctly contact your service provider for proper adjustment.

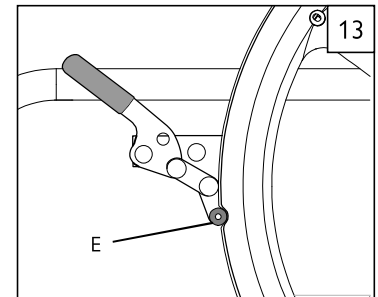
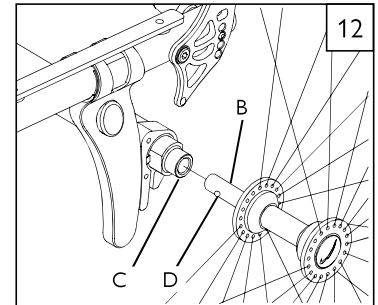
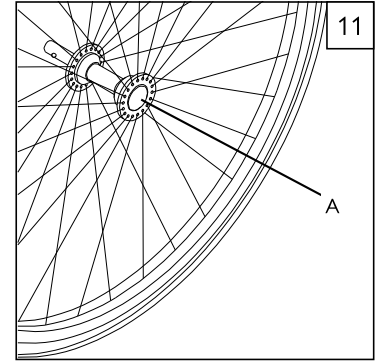

H. PADDED SWING-AWAY ARMRESTS (OPTION) 14**1. Installation**

- Slide the armrest into the receiver tube on rear of frame.
- Make sure the bolt (A) is located into the slot (B) on receiver tube.

2. Swinging Away

- Lift armrest out of the locked position and rotate to the side.

3. Removing Armrest

- Pull armrest straight out of the receiver.

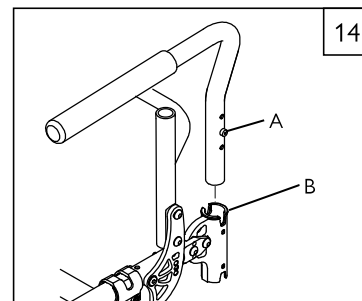
**I. HEIGHT-ADJUSTABLE ARMRESTS (Optional)** 15**1. Installation**

- Slide the outer armpost (1) into the receiver (7) mounted to the wheelchair frame.
- The armrest will lock into place if pressed down firmly.

2. Height Adjustment

- Rotate height release lever (2) to second stop.
- Slide armrest pad up or down to desired height.
- Return lever to locked position against armpost.
- Push arm pad (4) down until upper armpost locks firmly into place.

3. Removing Armrest

- To remove the armrest, grip the release lever (3) to unlock and remove the armrest.

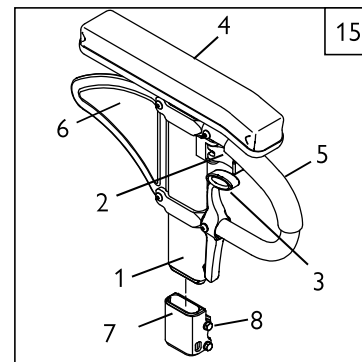

- Outer armpost
- Height release Lever
- Release lever
- Armrest pad
- Transfer bar
- Side panel
- Receiver
- Clamp

J. FLIP-UP FOOTPLATE 16

The footplate (C) can be rotated up towards the user for transfers and adjustment.

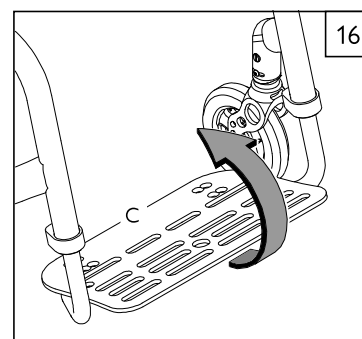

K. BACK ANGLE PERFORMANCE 17 18**Adjusting the Angle of the Backrest**

1. Release the backrest by pulling the adjustable tension pull cord (A) with a simple, short force.
2. While maintaining tension on the release cord, rotate the backrest to the desired angle, either forward or rearward.
3. Lock the backrest in place by releasing the cord and allowing the pins (B) to engage in the nearest hole (C) of the backrest bracket (D).

Folding and Unfolding the Backrest

1. Release the backrest by pulling the adjustable tension pull cord (A) with a simple, short force.
2. While maintaining tension on the release cord, rotate the backrest to unfold it. Remove the cushion and push down hard to lock it in the folded position.
3. Lock the backrest in the folded position by removing your cushion. Release the pull-cord, and push down hard allowing the pins (B) to engage in the folded position hole (E) of the backrest bracket (D).

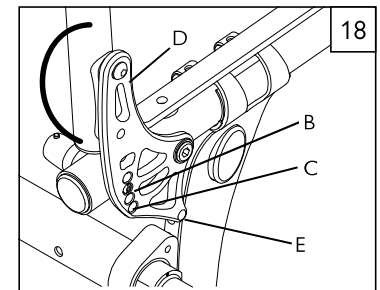
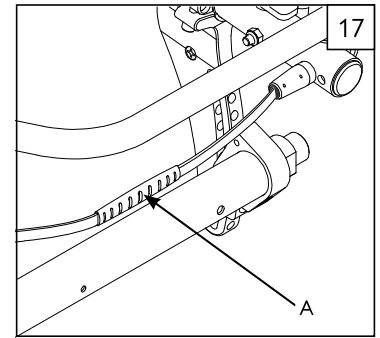
**⚠ WARNING**

Be sure the pins (B) are fully engaged through the backrest bracket (D) on both sides of the chair. Test the backrest to be sure it is locked before use.

L. BACKREST TENSION ADJUSTABLE 19 20 21 22**To install the Backrest Tension Adjustable**

1. Slide Velcro® straps (F) over the backrest frame (G) section. Make sure to include at least one strap below the towel bar (if using a rigid chair).
2. Tighten the straps appropriately to desired tension level. DO NOT over tighten straps as this will cause undue strain upon the chair backrest frame (G).
3. If using fold down push handles, insert the single Velcro® strap (F) through the slots in the front of the push handles (I).
If using integral push handles (J), slide straps from bottom of backrest upward.
4. Install backrest cover at desired level and fold over rear of Velcro® strapping system (K). The Quickie patch should be upright on the rear of the chair.
5. Finish installation by placing vanity flap (center panel) down onto Velcro® on the seat sling to secure attachment (L).

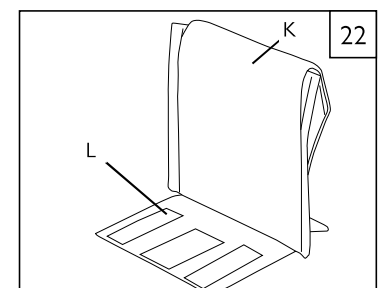
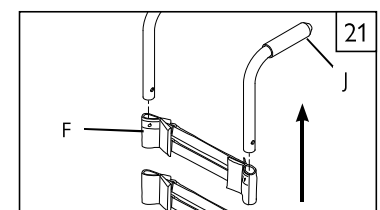
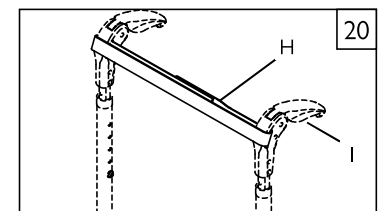
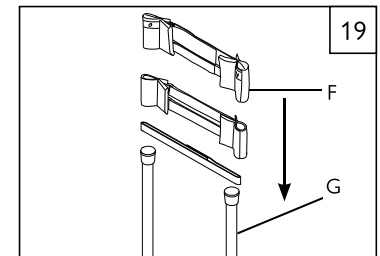
**Adjusting the Backrest Tension Adjustable**

Always use anti-tips while making any adjustments. Ensure anti-tips are safely secured and in a position to prevent the wheelchair from tipping backwards.

1. User can transfer into wheelchair. Place wheel locks in the locked position
2. From the rear of the wheelchair the attendant can lift the Vanity Flap (center panel) to access the strap system. Adjust straps for optimal balance and trunk alignment. Ensure the Velcro® straps have a minimum of 2 inches (5cm) of engagement. Hook the Velcro® after securing it through each loop. Press the Velcro® together to ensure its securely engaged.
3. Once adjustments are complete replace Vanity Flap to its original position.

⚠ WARNING

Any changes made to the straps will affect the center of gravity. It is best to have the attendant stationed behind the wheelchair to prevent the wheelchair from tipping backwards while the user becomes accustomed to the adjustment.

M. CUSHION INSTALLATION

Place cushion on seat sling with Velcro® side down. The beveled edge of the cushion should be in front. Press firmly into place.

N. STORAGE TIPS

1. Store your chair in a clean, dry area. If you fail to do so, parts may rust or corrode.
2. Before using your chair, make sure it is in proper working order.
3. Inspect and service all items on the "Maintenance Chart".
4. If stored for more than three months, have your chair inspected by an authorized dealer before use.

O. CHECK-OUT

After the wheelchair is assembled and adjusted, it should roll smoothly and easily. All accessories should also perform smoothly. If you have any problems, follow these procedures:

1. Review the set-up and check-out sections and operating guide to make sure chair was properly prepared.
2. Review the troubleshooting chart at the beginning of this section.
3. If your problem persists, contact your authorized dealer. If you still have a problem after contacting your authorized dealer, contact Sunrise customer service. See the Introduction Page for details on how to contact your authorized dealer or Sunrise customer service.

⚠ WARNING

The owner of this chair is responsible for making sure that it has been setup and adjusted by a trained service professional under the advice of a healthcare professional. Service and/or adjustments should only be done with the advice of a healthcare professional. Always use parts and/or accessories that have been recommended and approved by Sunrise Medical when servicing this chair.

A. DEALER SERVICE INTRODUCTION 23

1. At least once per year, this chair should have a complete inspection, safety check, and regular service made by an authorized dealer. The tool list at right is a good starting point for proper maintenance.
2. If you have discovered a worn, bent, or damaged part, repair or replace them with recommended parts before returning this chair to service.
3. All major maintenance and repair work should be done by the authorized dealer.

B. CRITICAL MAINTENANCE TIPS

1. Torque settings:

A torque setting is the optimum tightening which should be made on a particular fastener. It is important to use proper torque settings where specified. When not specified, torque settings should be 60 in-lbs

2. Dealer Service and Adjustment Reference materials:

Go to www.SunriseMedical.com for parts manuals, instruction sheets, and instructional videos that will aid in the repair of your Quickie wheelchair.

C. CLEANING

1. Paint Finish

- a. Clean the painted surfaces with mild soap or detergent.
- b. Protect the paint with a coat of non-abrasive auto wax.

2. Axles and Moving Parts

- a. Clean around axles and moving parts with a slightly damp (not wet) cloth.
- b. Wipe off or blow away any fluff, dust or dirt on axles or moving parts.
- c. DO NOT USE 3-in-ONE oil, or WD-40® for lubrication. Only use Teflon based Lubricant when working on this wheelchair.

D. REAR WHEEL AXLE NUT ADJUSTMENT 24 25

To adjust the rear axle you will need a 3/4" wrench (A) to turn the adjustment nut (B). You will also need a 1/2" wrench (C) to securely hold the end (D) of the axle to prevent it from turning.

If the wheel and axle will not lock into the camber plug then the axle requires adjustment. Turn the nut (B) counter-clockwise approximately 1/4 revolution and try to lock the axle into the camber plug. If it doesn't lock, continue making small nut adjustments until it securely locks.

If the wheel is locked on the chair but there is excessive wheel play (the wheel hub can be pushed back and forth on the axle) then adjust the nut (B) clockwise until there is no perceptible gap between the wheel and camber tube. Make sure the detent ball (D) on the axle is securely locked onto the chair.

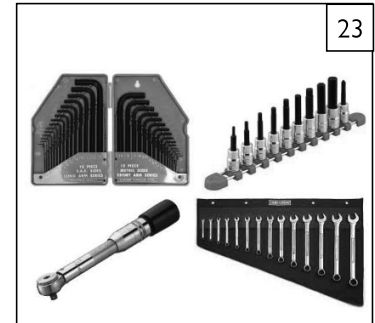

TOOLS YOU WILL NEED

1. Imperial hex key set
2. Metric hex key set
3. Imperial open-end wrench set
4. Metric open-end wrench set
5. Torque wrench
6. Imperial hex bit socket set
7. Metric hex bit socket set
8. Phillips and flat screwdrivers
9. Tire Pressure Gauge

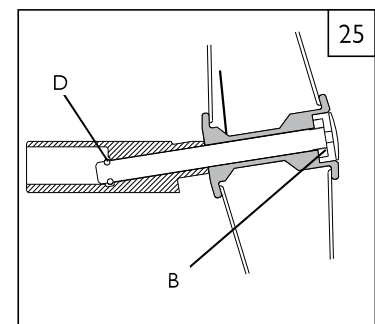
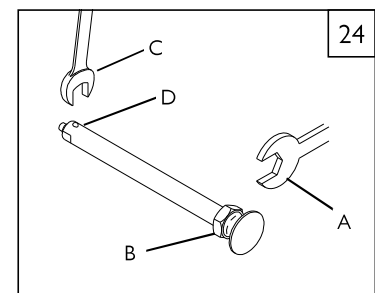

E. WHEEL LOCKS 26 27

Quickie 5R is shipped with one of two types of wheel locks. Wheel locks are installed at the factory unless you have requested otherwise.

Use a torque setting of 100 in-lbs. (11.3 Nm) when setting up wheel locks.

1. High-Mount Push-to-Lock or Pull-to-Lock Wheel Locks Adjustment 26

- Using a 4mm Allen wrench, turn one of the screws (A) in the clamp counterclockwise 1/4 turn.
- Repeat the same process with the remaining screw (A).
- Alternately loosen the screws (two turns each) until both screws are loose.
- Slide clamp toward the rear wheel until the wheel lock is embedded into the tire to prevent wheel movement when in the locked position.
- You can achieve extra lateral or angular adjustment by loosening the screw (B) on the wheel lock receiver clamp.
- Tighten screws to 100 in-lbs. (11.3 Nm).

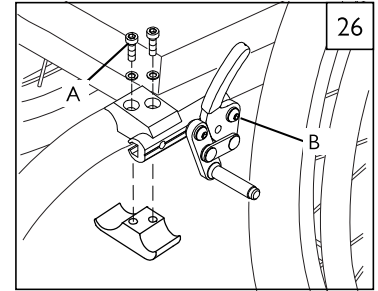
**2. Ergo Scissor Wheel Locks or Compact Wheel Locks** 27

- Using a 4mm Allen wrench, turn one of the screws (A) in the clamp counterclockwise one-quarter turn.
- Repeat the same process with the remaining three screws (A).
- Alternately loosen the screws (two turns each) until both screws are loose.
- Slide clamp toward the rear wheel until the wheel lock is embedded into the tire to prevent wheel movement when in the locked position.
- You can achieve extra lateral or angular adjustment by loosening the screw (B) on the wheel lock receiver clamp.
- Tighten screws to 100 in-lbs. (11.3 Nm).

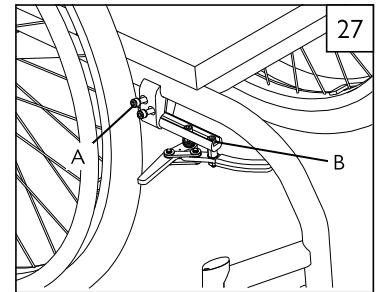

NOTE – Clamp and wheel lock may need to be rotated to clear frame tubing.

F. XTR SUSPENSION ANTI-TIP TUBES (Option) 28

Sunrise Medical recommends anti-tip tubes for all wheelchairs.

NOTE –Use torque setting of 100 in./lbs. when setting-up anti-tip tubes.

1. Adjusting Anti-tip Receiver

- Remove anti-tip tubes (G) from anti-tip receivers (H).
- Remove button head bolt (I) from anti-tip tube receiver.
- Reposition bracket to desired height.
- Reinsert button-head bolt and tighten.
- Repeat with second anti-tip tube receiver. Both brackets should be at exactly the same height.

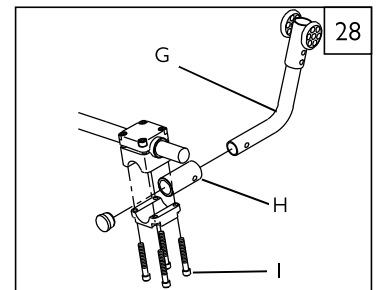

G. ARMREST RECEIVER ATTACHMENT**1. Adjusting Armrest Receiver Fit** 29 30

To tighten or loosen the fit of the outer armrest (A) in the receiver (B):

- a. Loosen the four receiver adjustment bolts (C) on the sides of the receiver.
- b. With the armrest in the receiver (B), squeeze the receiver to achieve the desired fit.
- c. Tighten the four bolts (C). (144 in-lbs, 16.3 Nm)

2. Position Adjustment 30

- a. Loosen the three clamp bolts (E) until clamp (D) is loose.
- b. Slide armrest receiver to desired position.
- c. Tighten all three bolts (E) to 212 in-lbs. (24 Nm).

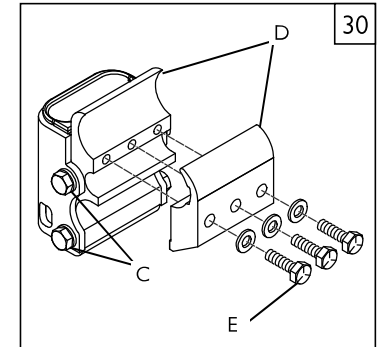
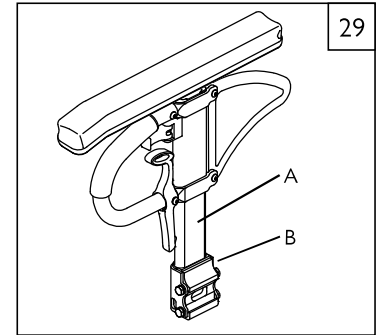
**H. PADDED SWING-AWAY ARMRESTS (OPTION)** 31

Swing-away armrests can be detached or can swing away (F) to allow lateral transfers. They are height adjustable 6" (15cm) of adjustment in 1" (2.5cm) increments by moving bolts (H) up or down in pre-drilled holes on armrest receiver (G).

Swing-away, angle adjustable

To change the angle of the armrest, remove the hardware (H). Reposition to the desired angle. Reinsert the hardware and tighten.

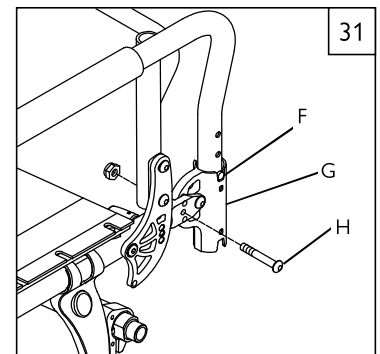
**I. FOOTREST ADJUSTMENT** 32 33**⚠ WARNING**

The footrest is an integral part of the frame. Do not remove the footrest. It is recommended that you maintain a minimum of 2 inches (5cm) between the lowest point on the footrest and the floor (I). This will provide adequate clearance for uneven surfaces and prevent damage to your footrest.

1. Height and angle adjustment

- a. Adjust the height of your footrest, by loosening the Set screws (I) in the front hanger frame.
- b. To adjust the angle of the footplate, loosen the screw (J) and rotate the footrest angle stop bracket. Once positioned, retighten screw(s) (J) to 92 in-lbs. For certain narrow widths, only one bolt will be present.
- c. Remember to tighten the set screws (I) before riding, use a maximum torque setting of 144 in-lbs or (16.3 Nm)

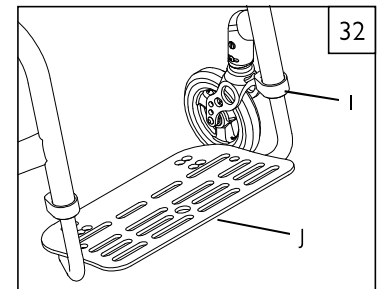
**2. Tubular Footrest height adjustment** 33

- a. Loosen the two clamp set screws in the back of the hanger frame tubes (K) on both sides of the chair.
- b. Slide footrest to desired height.
- c. Tighten the hardware to 144 in-lbs (6.3 Nm) on both sides.

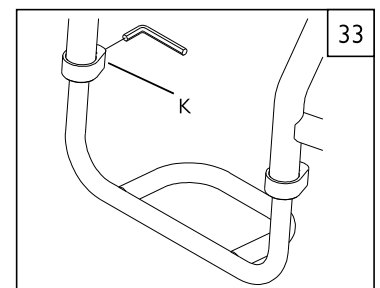

J. CASTERS

NOTE – Setting the wheelchair on a very flat table or a workbench makes this setting more accurate.

1. Adjusting Caster Angle 34 35**Checking for Caster Squareness:**

The Quickie wheelchair leaves the factory with the casters adjusted square. Any time a change is made to the wheelchair rear axle height, rear tire size, center of gravity position or camber tube, check that the casters are still square. A caster that is not square will result in the caster lifting off the floor as it rotates around the stem bolt and may also lift the front of the wheelchair up and down. Check for squareness by placing the wheelchair on a flat, horizontal surface. Rotate both forks so that the casters are towards the rear of the wheelchair. Place a square or pocket level against the flat surface on the rear of the fork and note whether this surface is vertical (square). If this surface is more than 1° degree away from vertical, the casters require re-squaring.

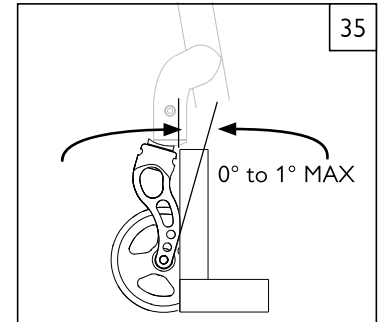
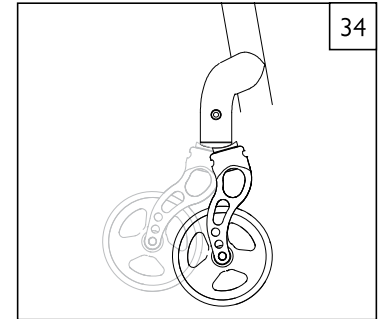
**2. Re-squaring the Casters** 36 37

- Locate the bolt (A) inside the right caster tube and loosen (do not remove) using a 10mm open end wrench. Loosen this bolt enough to allow the teeth on the upper and lower splines (B) to clear one another. The caster fork should pivot freely.
- Place the wheelchair on the floor so that the two rear wheels and left caster contact the floor. Place some weight in the seat towards the rear to help stabilize the chair. Place a square or pocket level against the flat surface of the fork and pivot the fork until it is vertical or 90° to the riding surface (square).
- With the fork vertical, engage the teeth of the two splines to the closest mating position. Make certain that the teeth are properly engaged and not crossed. Shine a bright light behind the mating spline teeth and check for proper teeth engagement.
- Tighten the screw (A) to secure the spline mating position. The screw should be tightened to a minimum of 100 in-lbs. (11.3 Nm) to ensure that it does not loosen during use.
- Record the teeth engagement position of the splines on the right fork, and adjust the left fork in a similar fashion to the same position. Reassemble both casters, and re-check that they are square.

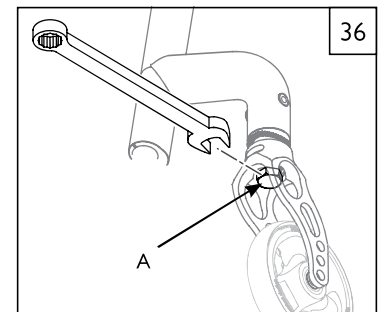
**3. 3-D Perpendicular Alignment** 38

- The hex bolt adjustment (C) provides another dimension of adjustability in addition to the spline system.
- The caster angle may then be fine-tuned and the bolt retightened.

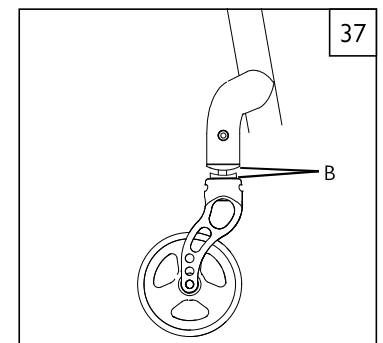
**4. Correcting a Pull to the Right or Left** 36 38

Determine which direction the chair is pulling (right or left). Make the following adjustments to the caster on that side of the chair:

- Loosen the bolt (A) inside the caster tube using a 10mm open-end wrench.
- Loosen the screw on the upper spline (C).
- Rotate the upper spline (D) to turn the caster fork toward the forward driving direction. Turn the ring clockwise, and the fork will swing outwards. Turn the ring counter-clockwise, and the fork will swing inwards.
- When the caster fork is correctly rotated forward, retighten the screws.
- After making the desired adjustment, recheck the squareness of the casters.
- Re-torque Bolt (A) to a minimum of 100 in-lbs (11.3Nm).

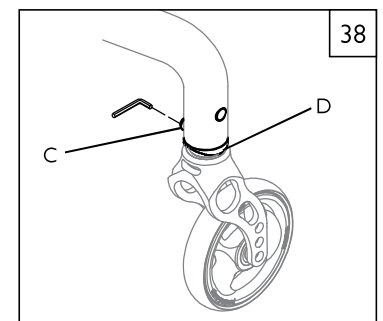

K. ANTI-FLUTTER KIT INSTALLATION 39 40 41

1. Remove fork assembly from chair. This may or may not require the removal of the caster wheel.
2. Insert anti-flutter bushing (A) into the slot (B) at the rear of the fork ensuring the tab goes between the ends of the snap ring and between the bearings.
3. Install clamp (C) over the top of the fork assembly inserting the inside tab (D) in the front slot (E).
4. Gently flex the clamp tabs (F) apart to allow it to slide over the recently installed bushing (A).
5. Squeeze the tabs (F) back together and install the socket head cap screw (G) into the clamp, ensure threads are properly aligned and lightly tighten using a 3mm hex key.

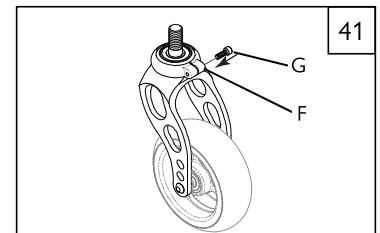
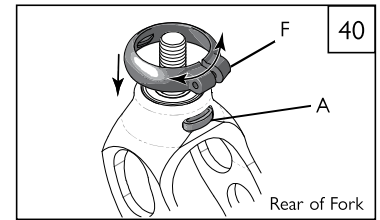
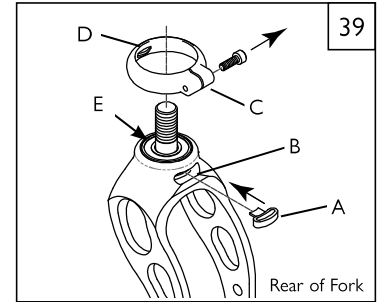
**L. BACK ADJUSTMENTS**

CAUTION – When changing the back angle of the wheelchair both the left and right angle adjustable back bracket must be in the same hole position before the wheelchair is to be used.

Adjusting Backrest Options 42

The backrest bracket has two positions, 1 or 2, that can be achieved by removing bolt (H) and pivoting the back cane forward or rearward. With the back cane in the desired position, reinsert and tighten the bolt. Then follow the instructions for “Folding and Unfolding the Backrest”.

1= Forward Mount. 2= Rearward Mount

Backrest Angle Preset Plugs 43

The preset plugs allow you to unemploy the backrest bracket holes you do not wish to use. This allows the backrest to automatically lock into your desired angle position after unfolding.

1. Determine which backrest bracket holes you do not want to use.
2. Insert plugs (J) into the predetermined holes from the chair side of the bracket (K).
3. To ensure the backrest locks in the folded position, do not insert a plug into the lowest hole (L).

Depth Adjustable Back (DAB) Plugs 43

The DAB Frame insert plugs (M) allow you to compensate for a thicker or thinner after-market backrest without having to change the Center of Gravity (CG) of the person in the wheelchair.

1. The backrest may be adjusted by first removing the JAY® style quick-release lanyard cord (not shown) from the backrest release pins.
2. Using a 5mm and 10mm hex key, remove the bolt holding the backrest bracket to the chair.
3. Remove the quick-release pins, frame bushing, and springs.
4. If the desired back depth is 1" (2.5cm) greater, move the plunger bushing back one hole. If the desired back depth adjustment is 2" (5cm), the plunger bushing must be moved to the most rearward hole.
5. To reassemble the back, reinsert the springs into the bushings. Then reinsert the quick-release pins into the bushings with the lanyard attachment holes first.
6. Reposition the backrest in place in the folded position. Insert the quick-release pin into its appropriate placement hole.
7. Insert the large Belleville washer in between the backrest bracket and the frame. Insert the backrest plate pivot bolt into the chair and secure using the washer and nylock nut.
8. Using the 5mm hex key and 10mm Allen Wrench, tighten the nylock nut so that the end of the bolt reaches the end of the nut. Repeat on the opposite side of the chair.

NOTE – Do not over-tighten the backrest plate pivot bolt as it may hinder the backrest from folding properly.

9. Re-attach the JAY®-style quick-release lanyard to the quick-release pins.

NOTE – This adjustment is intended to compensate for differences in after-market backrest thickness and/or contour. The back-canes can be adjusted fore and aft relative to the seat so that the backrest support surface does not change the location of the user, regardless of the backrest mounting location. This ensures that the center of gravity of the user relative to the axle location, is not altered due to after-market backrest thickness or contour. There is no recommendation for Depth Adjustable Backrest use for transit.

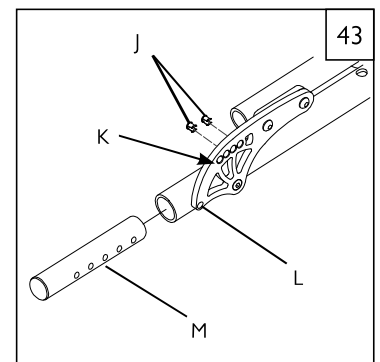
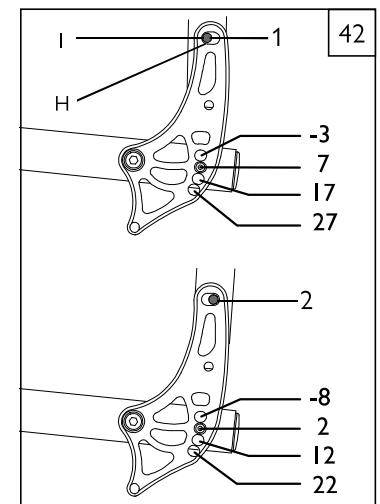

Non-folding back instructions 44

1. Remove backrest bracket bolt (A).
2. Rotate the backrest to the desired angle.
3. Align desired backrest bracket hole with seat frame opening.
4. Re-insert bolt and tighten.

CAUTION – When changing the back angle of the wheelchair both the left and right angle adjustable back bracket must be in the same hole position before the wheelchair is to be used.

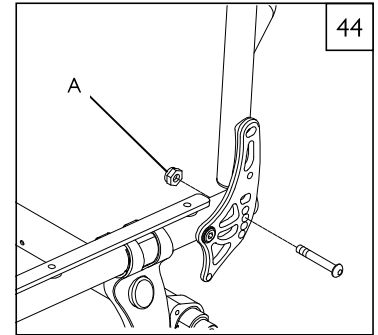
**M. REAR AXLE ADJUSTMENTS****1. Wheel Camber** 45

Wheel camber, shown as angular relationship (B), provides greater side-to-side stability due to the increased width and angle of the wheelbase. It also allows for quicker turning and greater access to the top of the handrims.

Wheel camber is determined by pairs of interchangeable camber plugs which are available from your authorized dealer in 0°, 3°, and 6° angles.

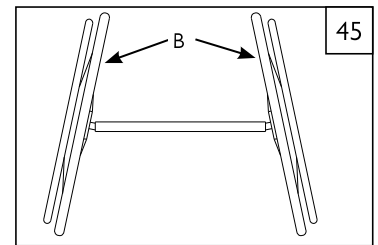
**2. Changing the Camber Plug** 46

Before changing the camber plug, note the camber tube bolt positions.

- a. To change the camber of your chair, loosen bolt (D) on both camber tube clamps (E). Then loosen the second bolt (F). Repeat on other side.
- b. Now the camber tube (C) and camber tube clamps (E) can be removed from the axle plate (G).
- c. Once removed from the axle plate, the camber tube clamps can be removed from the camber tube. You can now remove the camber plug (H).
- d. Insert the desired camber plug into each end of the camber tube. Then replace the camber tube clamps on the ends of the camber tube. Be sure to space camber plugs equal distance from the ends of the camber tube.
- e. Slide camber tube assembly onto axle plate. Realign axle plate holes to their original position. Tighten bolts (D) then replace and tighten all bolts to 100 in-lbs (11.3 Nm)

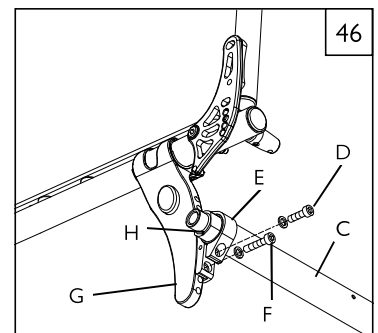
**3. Setting toe-in toe-out to the ground** 47 48 49 50

NOTE – A wheelchair equipped with 0° camber plugs cannot have a toe-in toe-out condition. This adjustment is only required when using 3°, 6° camber plugs.

“Toe” refers to how well the rear wheels of the chair are aligned relative to the ground. It affects how well the chair will roll. Drag or rolling resistance is optimally minimized when the wheel toe is set to zero.

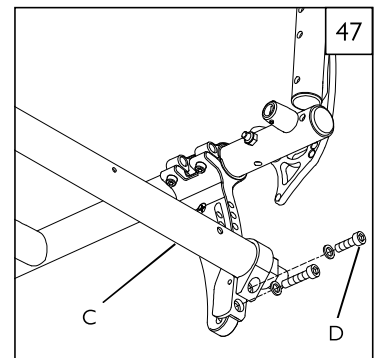
**4. Setting the Toe to Zero** 47 48

- a. Place the entire wheelchair on a flat horizontal table or ground surface. Loosen the 2 cap screws (D) (1 per side) that secure the camber tube clamp.
- b. Locate the flat surfaces on the front and rear of the camber plugs (E). Place an object that is known to have an accurate 90° corner (such as a carpenter's square, drafting triangle, etc.) down on the flat horizontal surface and up against the flat of the camber plug.
- c. Rotate the camber tube and plug assembly until the flat surface of the camber plug is parallel to the measuring tool.
- d. Before tightening the screws (D), make certain that the camber tube is centered left-to-right relative to the wheelchair frame. There should be an equal gap on both sides of the wheelchair or none at all. Torque the fasteners to 100 in-lbs. (11.3 Nm).

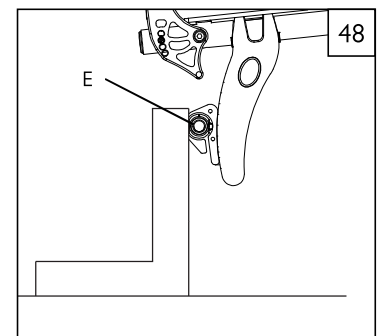

5. Setting the Toe to Zero – Alternative Method 47 49 50

- Loosen the 2 cap screws (D) (1 per side) that secure the camber tube clamp. Observe the ball in the level (B), and rotate the camber tube (C) until the ball is centered in the level. The toe is now set at zero.
- Before tightening the screws (D), make certain that the camber tube is centered left-to-right relative to the wheelchair frame. There should be an equal gap on both sides or none at all. Torque fasteners (D) to 100 in.-lbs. (11.3 Nm).

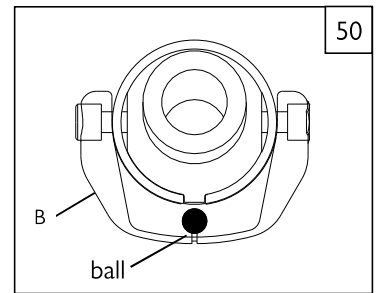
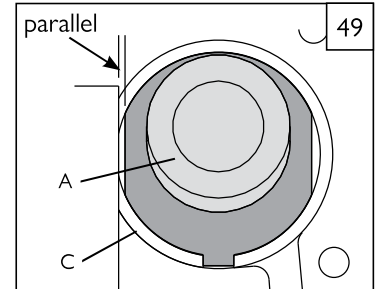
**N. CENTER OF GRAVITY (CG) ADJUSTMENT** 51

The most important adjustment on your Quickie wheelchair is the position of the rear axle. The center of gravity, wheel camber and wheelbase are all determined by the axle adjustment.

NOTE - Use a torque setting of 60 in.-lbs. when adjusting rear axle clamp bolts (E).

1. Center of Gravity

Moving the center of gravity to the front will lighten the force required to turn the chair. The further back the axle and clamp, the more stable the chair becomes.

The center of gravity is adjusted by moving the rear axle and clamp forward or backward on the frame. Moving the axle and clamp forward will increase your turning speed and lighten the front end.

IMPORTANT NOTE: Changing the center of gravity increases the risk of a fall or tip over. Be very careful to assure the chair will not tip over backwards when tilted.

2. To Move Center of Gravity 51

Loosen cap head screws (E). Slide camber tube assembly forward or rearward along frame tube. Retighten the screws. Be sure to measure the new position for evenness on both sides of the chair.

Once the axle plate clamps are secured, attach the rear wheels, occupy the chair and maneuver it with a spotter to get a feel for the new adjustment.

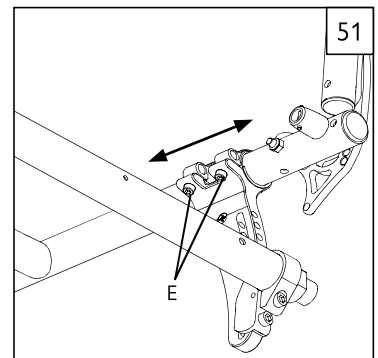

O. REAR WHEEL SPACING 52 53 54

Rear wheel spacing is measured as the gap between the top of the rear wheels and the back-canes, and is shown as dimension (A) factory settings will be as narrow as possible depending on the options chosen.

NOTE –When setting the rear wheel spacing only make adjustments to one side of the chair at a time. Loosening both sides will undo the toe setting.

- To adjust the rear wheel spacing, the camber inserts (B) telescope in and out of the camber tube (C) with hard stops at each end of travel.
- On the left side of the chair, loosen screw (D) (the one closest to the camber tube). Slide the camber insert in or out to establish the required wheel spacing.
- Tighten screw to 100 in-lbs (11.3Nm). Repeat on the right side of the chair, matching the wheel spacing set on the left side.

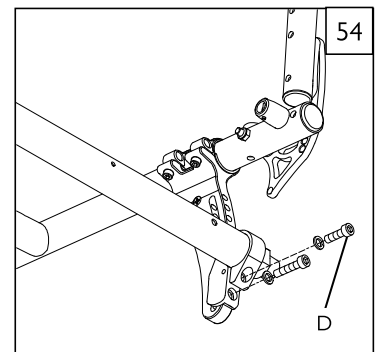
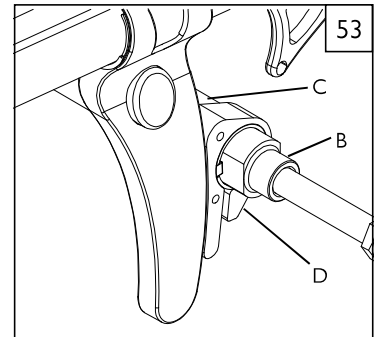
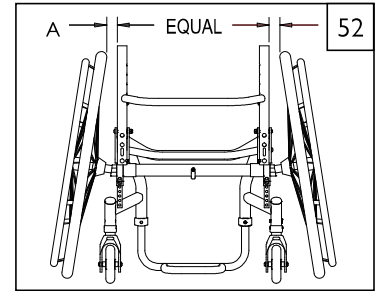
**P. SEAT SLING ADJUSTMENT** 55

- Remove the bolts (E) and rear bolt nut (F) to allow seat upholstery (G) to be removed from frame.
- To reattach seat sling, place seat sling (G) over chair frame. Line up seat sling and plastic saddles. Replace the screws (E) and rear nut (F) and tighten accordingly.
- Retain plastic saddles (not shown) for placement between seat sling and frame. Repeat steps for other side.

If there is any difficulty in reattaching the screws, try using a probe to help align the holes. Ensure that the plastic saddles are under the seat rail in all fastener positions.

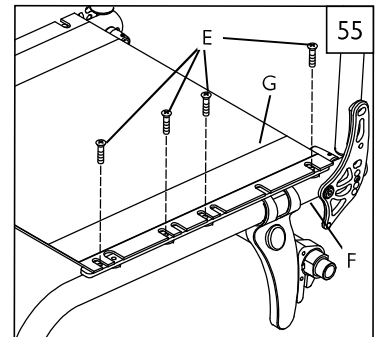
**Q. REAR SEAT HEIGHT ADJUSTMENT** 56

- To adjust rear seat height, loosen and remove the 4 cap screws (H) (2 per side) that secure the camber tube clamps (I) to the axle plates (J).
- Move both camber tube clamps (I) to the desired height and reinstall the 4 cap screws. Prior to tightening, follow the instructions for setting the toe-in/out to zero.
- Tighten screws to 100 in-lbs. (11.3 Nm).

NOTE – Adjustment to rear seat height may also require caster angle adjustment.

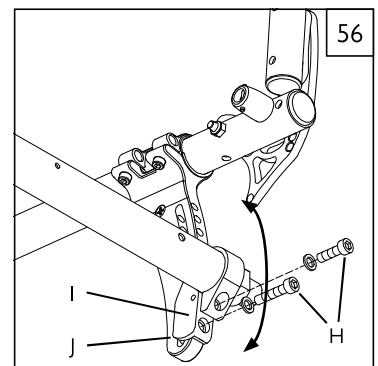

R. REAR AXLE PLATE SUSPENSION 57

The performance of the suspension system is determined by the compression elastomers (A). There are several different elastomers available from Quickie which are selected based on the user's weight.

To change out elastomers, remove the 2 screws (C) (1 per side). Rotate swingarms (B) downward and the compression elastomer (A) can be freely removed from its top and bottom engagement sockets.

Reverse the order to install new bushings, making sure the compression elastomers are securely engaged into the top and bottom sockets.

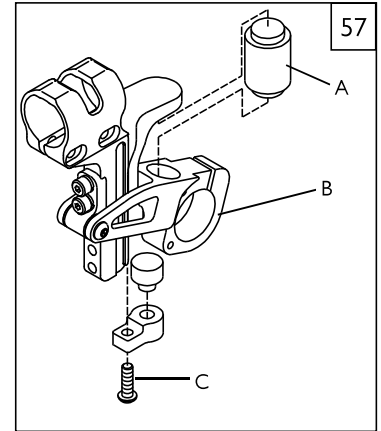
**S. XTR SUSPENSION (optional)** 58

- Tuned to perform in conjunction with Quickie 5 series.
 - Adjustable spring pre-load
1. If the shock ever loses oil or if it makes sounds of excessive topping out, stop use immediately and have the shock inspected by your authorized dealer. Continued use with the shock in either of these conditions could result in loss of control with possible serious and/or fatal injuries.
 2. Always use genuine Quickie parts. Use of after-market replacement parts voids the warranty and could cause structural failure to the shock. Structural failure could result in loss of control with possible serious and /or fatal injuries

Tuning Your Shock 58

By matching the proper spring rate and damping adjustment, your shocks can be tuned to your weight.

When tuning suspension, always make one change at a time and write it down. This takes patience, but allows you to understand how each change affects your ride. Keeping a record lets you know what changes you have tried that work and suggests what changes you might try.

Washing the Deluxe Shock

Clean the shock with mild soap and a toothbrush. Keep the shaft and body eye bushings clean and greased.

IMPORTANT: NEVER USE A HIGH-POWERED WASHER FOR CLEANING THE SHOCK!

Adjusting the Shock Tension

Locate the spring preloading adjuster ring (4). Rotate adjuster ring clockwise to decrease tension. Rotate adjuster ring counter-clockwise to increase tension.

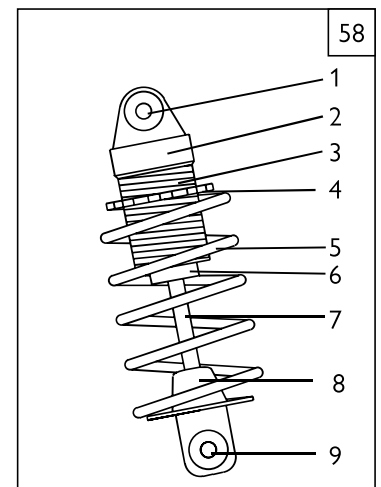

1. Body eye
2. Reservoir
3. Body threads
4. Spring adjuster ring
5. Coil spring
6. Seal head
7. Shock shaft
8. Bottom out bumper
9. Shaft eye

⚠ WARNING

Test your new chair settings with a spotter before proceeding with use.

T. CHECK-OUT

After the wheelchair is assembled and adjusted, it should roll smoothly and easily. All accessories should also perform smoothly. If you have any problems, follow these procedures:

1. Review the set-up and check-out sections and operating guide to make sure chair was properly prepared.
2. Review the troubleshooting chart at the beginning of this section.
3. If your problem persists, contact your authorized dealer. If you still have a problem after contacting your authorized dealer, contact Sunrise customer service. See the Introduction Page for details on how to contact your authorized dealer or Sunrise customer service.

A. FOR LIFETIME

Frame and cross-brace (if applicable) warranty:

1. Although the anticipated useful service time of this wheelchair is five years, Sunrise guarantees the frame and cross brace against defects in material and workmanship for life or for as long as the original purchaser owns the chair.
2. This warranty does not apply if:
 - a. The chair is subject to abuse
 - b. The chair is not maintained as recommended in the owner's manual
 - c. The chair is transferred to a different person from the original owner

B. FOR ONE (1) YEAR

We warrant all Sunrise-made parts and components of this wheelchair against defects in materials and workmanship for one year from the date of first consumer purchase.

Backrest Tension Adjustable (Ballistic & 3DX Vented)

Each Backrest Tension Adjustable is carefully inspected and tested to provide peak performance. Every Backrest Tension Adjustable is guaranteed to be free from defects in materials and workmanship for a period of twelve (12) months from the date of purchase provided normal use. Should a defect in materials or workmanship occur within twelve months from the original date of purchase, Sunrise Medical will, at its option, repair or replace it without charge. This warranty does not apply to puncture, tears or burns. Claims and repairs should be processed through the nearest authorized dealer. Except for express warranties made herein, all other warranties including implied warranties of merchantability and warranties of fitness for particular purpose are excluded. There are not warranties which extend beyond the description of the face hereof. Remedies for breach of express warranties herein are limited to repair or replacement of the goods. In no event shall damages for breach of any warranty include any consequential damages or exceed the cost of non-conforming goods sold.

C. LIMITATIONS

1. We do not warrant:
 - a. Tires and tubes, upholstery, pads and push-handle grips.
 - b. Damage from neglect, accident, misuse, or from improper installation or repair.
 - c. Products modified without Sunrise Medical's express written consent.
 - d. Damage from exceeding the weight limit.
5. This warranty is VOID if the original chair serial number tag is removed or altered.
6. This warranty applies in the USA and Canada only. Check with your supplier to find out if international warranties apply.
7. This warranty is not transferable and only applies to the first consumer purchase of this wheelchair through an authorized Sunrise Medical dealer.

D. WHAT WE WILL DO

Our sole liability is to repair or replace covered parts. This is the exclusive remedy for consequential damages.

E. WHAT YOU MUST DO

1. Obtain from us, while this warranty is in effect, prior approval for return or repair of covered parts.
2. Return the wheelchair or part(s), freight pre-paid to the designated Sunrise Medical location.
3. Pay the cost of labor to repair, remove or install parts.

F. NOTICE TO CONSUMER

1. If allowed by law, this warranty is in place of any other warranty (written or oral, express or implied, including a warranty of merchantability, or fitness for a particular purpose).
2. This warranty gives you certain legal rights. You may also have other rights that vary from state to state or province to province.

G. ADDITIONAL WARRANTY INFORMATION

For goods provided by Sunrise Medical Pty Ltd in Australia, our goods come with a guarantee by Sunrise that cannot be excluded under the Australian Consumer Law. You are entitled to a replacement or refund for a major failure and for compensation for any other reasonably foreseeable loss or damage. You are also entitled to have the goods repaired or replaced if the goods fail to be of acceptable quality and the failure does not amount to a major failure. The benefits to you given by this warranty are in addition to your other rights and remedies under a law in relation to the goods to which the warranty relates.

Record your serial number here for future reference:

Sunrise Medical S.r.l.
Via Riva, 20 – Montale
29122 Piacenza
Italia
Tel.: +39 0523 573111
www.SunriseMedical.it

Sunrise Medical AG
Erlenauweg 17
CH-3110 Münsingen
Schweiz/Suisse/Svizzera
Tel +41 (0)31 958 3838
www.SunriseMedical.ch

Sunrise Medical AS
Delitoppen 3
1540 Vestby
Norge
Telefon: +47 66 96 38 00
post@sunrisemedical.no
www.SunriseMedical.no

Sunrise Medical AB
Neogatan 5
431 53 Mölndal
Sweden
Tel.: +46 (0)31 748 37 00
post@sunrisemedical.se
www.SunriseMedical.se

MEDICCO s.r.o.
H – Park, Heršpická 1013/11d,
639 00 Brno
Czech Republic
Tel.: (+420) 547 250 955
Fax: (+420) 547 250 956
www.medicco.cz
info@medicco.cz
Bezplatná linka 800 900 809

Sunrise Medical Aps
Mårkærvej 5-9
2630 Taastrup
Denmark
+45 70 22 43 49
info@sunrisemedical.dk
www.SunriseMedical.dk

Sunrise Medical Australia
11 Daniel Street
Wetherill Park NSW 2164
Australia
Ph: +61 2 9678 6600
Email: enquiries@sunrisemedical.com.au
www.SunriseMedical.com.au

Sunrise Medical (US) LLC
North American Headquarters
12002 Volunteer Blvd.
Mount Juliet, TN 37122, USA
(800) 333-4000
(800) 300-7502
www.SunriseMedical.com



© 2025 Sunrise Medical (US) LLC
MK-100083 Rev. B

Sunrise Medical GmbH
Kahlbachring 2-4
D-69254 Malsch
Deutschland
Tel.: +49 (0) 7253/980-0
Fax: +49 (0) 7253/980-222
www.SunriseMedical.de

Sunrise Medical Ltd.
Thorns Road
Brierley Hill
West Midlands
DY5 2LD
England
Phone: 0845 605 66 88
Fax: 0845 605 66 89
www.SunriseMedical.co.uk

Sunrise Medical S.L.
Polígono Bakiola, 41
48498 Arrankudiaga – Vizcaya
España
Tel.: +34 (0) 902142434
Fax: +34 (0) 946481575
www.SunriseMedical.es

Sunrise Medical Poland
Sp. z o.o.
ul. Elektronowa 6,
94-103 Łódź
Polska
Telefon: + 48 42 275 83 38
Fax: + 48 42 209 35 23
E-mail: pl@sunrisemedical.de
www.Sunrise-Medical.pl

Sunrise Medical B.V.
Defensiedok 20
3433 NE Nieuwegein
The Netherlands
T: +31 (0)30 – 60 82 100
F: +31 (0)30 – 60 55 880
E: info@sunrisemedical.nl
www.SunriseMedical.nl

Sunrise Medical HCM B.V.
Vossenbeemd 104
5705 CL Helmond
The Netherlands
T: +31 (0)492 593 888
E: customerservice@sunrisemedical.nl
www.SunriseMedical.nl
www.SunriseMedical.eu (International)

Sunrise Medical S.A.S
ZAC de la Vrillonnerie
17 Rue Mickaël Faraday
37170 Chambray-Lès-Tours
Tel : + 33 (0) 2 47 55 44 00
Email: info@sunrisemedical.fr
www.SunriseMedical.fr

Sunrise Medical Canada Inc.
1000 Creditstone Rd., Unit #2
Concord, ON, L4K 4P8
Canada
Phone: 1-800-263-3390
Fax: 1-800-561-5834
www.SunriseMedical.ca