

## Zippie® Sphynx

**Supplier:** This manual must be given to the rider of this wheelchair.  
**Rider:** Before using this wheelchair read this entire manual and save for future reference.

Owner's Manual

## Zippie® Sphynx

**Distribuidor:** Este manual debe ser entregado al pasajero de esta silla de ruedas.  
**Pasajero:** Antes de usar esta silla de ruedas, lea este manual en su totalidad y guárdelo para futura referencia.

Manual de Instrucciones

Cada una de las sillas se envía con un manual de instrucciones en inglés. El manual en español y francés está disponible en formato PDF en nuestra página en Internet: [www.SunriseMedical.com](http://www.SunriseMedical.com). Ingrese a la página del producto específico para descargar el manual, o comuníquese con el proveedor autorizado de Sunrise Medical.

## Zippie® Sphynx

**Au Fournisseur:** Ce manuel doit être remis à l'utilisateur de ce fauteuil roulant.  
**À l'Usager:** Veuillez lire tout le manuel et le conserver pour référence ultérieure.

Manuel d'instructions

Chaque fauteuil est livré avec un manuel d'instructions en anglais. Les versions en espagnol et en français sont à votre disposition en format PDF sur le site : [www.SunriseMedical.com](http://www.SunriseMedical.com). Veuillez vous rendre à la page de votre produit pour télécharger le manuel dans la langue souhaitée, ou contactez un fournisseur agréé Sunrise Medical.

P/N 252843 Rev. E

# Zippie® Sphynx

Instructions for Use

**SUNRISE MEDICAL® LISTENS**

Thank you for choosing a Zippie® wheelchair. We want to hear your questions or comments about this manual, the safety and reliability of your chair, and the service you receive from your Sunrise Medical authorized dealer. Please feel free to write or call us at the address and telephone number below:

**SUNRISE MEDICAL (US) LLC**

Customer Service Department  
12002 Volunteer Blvd.  
Mount Juliet, TN 37122, USA  
(800) 333-4000



[www.SunriseMedical.com/register](http://www.SunriseMedical.com/register)

Please register your wheelchair and let us know if you change your address. This will allow us to keep you up to date with information about safety, new products, and options to increase your use and enjoyment of this wheelchair.

You can also register your wheelchair at:  
[www.SunriseMedical.com/register](http://www.SunriseMedical.com/register)

**FOR ANSWERS TO YOUR QUESTIONS**

Your authorized dealer knows your wheelchair best and can answer most of your questions about chair safety, use, and maintenance.

For future reference, please fill in the following:

Dealer: \_\_\_\_\_

Address: \_\_\_\_\_

Telephone: \_\_\_\_\_

Serial #: \_\_\_\_\_ Date/Purchased: \_\_\_\_\_

**ADDITIONAL INFORMATION YOU SHOULD KNOW**

No component of this chair was made with Natural Rubber Latex.

**DISPOSAL AND RECYCLING INFORMATION**

When this product reaches the end of its life, please take it to an approved collection or recycling point designated by your local or state government. This product is manufactured using a variety of materials. Your product should not be disposed of as ordinary household waste. You should dispose of your product properly, according to local laws and regulations. Most materials that are used in the construction of this product are fully recyclable. The separate collection and recycling of your product at the time of disposal will help conserve natural resources and ensure that it is disposed in a manner that protects the environment.

Ensure you are the legal owner of the product prior to arranging for the product disposal in accordance with the above recommendations.

## 2.0 TABLE OF CONTENTS

1.0 INTRODUCTION.....	2	7.0 WARNINGS: COMPONENTS AND OPTIONS.....	11
2.0 TABLE OF CONTENTS.....	3	A. ARMRESTS.....	11
3.0 YOUR CHAIR AND ITS PARTS .....	4	B. CUSHIONS & SLING SEATS.....	11
4.0 NOTICE - READ BEFORE USE .....	4	C. FASTENERS.....	11
A. CHOOSE THE RIGHT CHAIR & SAFETY OPTIONS.....	4	D. FOOTRESTS.....	11
B. REVIEW THIS MANUAL OFTEN.....	4	E. POSITIONING BELTS (Option) .....	11
C. WARNINGS.....	4	F. PUSH HANDLES .....	11
5.0 GENERAL WARNINGS.....	5	G. QUICK-RELEASE AXLES.....	11
A. WEIGHT LIMIT.....	5	H. REAR WHEEL HUB LOCK.....	12
B. INTENDED USE.....	5	I. MODIFIED SEAT SYSTEMS.....	12
C. ATTENDANTS AND CAREGIVERS .....	5	J. SEAT AND BACK UPHOLSTERY .....	12
D. ACCESSORIES.....	5	K. STROLLER HANDLE.....	12
E. KNOW YOUR CHAIR.....	5	L. TRAY FOR VENT AND BATTERY.....	12
F. REDUCE THE RISK OF AN ACCIDENT .....	5	M. ACCESSORY HOOK .....	12
G. SAFETY CHECKLIST.....	5	8.0 USE AND MAINTENANCE .....	13
H. CHANGES & ADJUSTMENTS.....	5	A. INTRODUCTION.....	13
I. ENVIRONMENTAL CONDITIONS .....	5	B. CRITICAL MAINTENANCE TIPS.....	13
J. TERRAIN.....	6	C. CLEANING TIPS.....	13
K. STREET USE.....	6	D. MAINTENANCE CHART .....	13
L. MOTOR VEHICLE SAFETY .....	6	E. TROUBLESHOOTING CHART.....	13
M. WHEN YOU NEED HELP .....	6	F. TO MOUNT AND REMOVE REAR WHEELS.....	14
N. CHOKING HAZARD.....	6	G. HUB LOCK.....	14
O. PINCH POINT .....	6	H. ADJUSTABLE LOCKING FLIP-UP ARMRESTS.....	14
6.0 SAFETY WARNINGS: FALLS & TIP-OVERS.....	7	I. FOOTRESTS, LEGRESTS, & FOOTPLATES.....	14
A. CENTER OF BALANCE.....	7	J. BACKREST UPHOLSTERY.....	15
B. DRESSING OR CHANGING CLOTHES.....	7	K. TENSION ADJUSTABLE UPHOLSTERY.....	15
C. OBSTACLES .....	7	L. SEATING AND SEAT SLING UPHOLSTERY.....	16
D. FRONT CASTER LIFT .....	7	M. ADJUSTING RECLINE ANGLE (Back to Seat angle) .....	16
E. REACHING OR LEANING.....	7	N. FOLDING AND UNFOLDING .....	17
F. MOVING BACKWARD.....	7	O. FOLDING ANGLE ADJUSTABLE PUSH HANDLES .....	18
G. ESCALATORS.....	8	P. CANOPY ATTACHMENT AND ADJUSTMENT.....	18
H. RAMPS, SLOPES & SIDEHILLS.....	8	Q. STORAGE TIPS.....	18
I. TRANSFERS .....	9	R. INSPECT .....	18
J. CURBS & SINGLE STEPS .....	9	9.0 DEALER SERVICE & ADJUSTMENT .....	19
K. CLIMBING A CURB OR SINGLE STEP .....	10	A. DEALER SERVICE INTRODUCTION .....	19
L. DESCENDING A CURB OR SINGLE STEP.....	10	B. CRITICAL MAINTENANCE TIPS.....	19
M. STAIRS.....	10	C. CLEANING.....	19
N. CLIMBING STAIRS .....	10	D. REAR WHEEL AXLE NUT ADJUSTMENT.....	19
O. DESCENDING STAIRS .....	10	E. ADJUSTABLE LOCKING FLIP-UP ARMRESTS.....	20
		F. ANGLE ADJUSTABLE HANGERS AND FOOTRESTS.....	20
		G. BACKRESTS .....	21
		H. SEAT SLING TENSION ADJUSTMENT .....	22
		I. ADJUSTING SEAT DEPTH.....	24
		J. ADJUSTING TILT ANGLE (Seat to Floor angle) .....	25
		10.0 SUNRISE LIMITED WARRANTY .....	27

**ZIPPIE SPHYNX**

1. Push Handle
2. Push Handle Angle Adjustment button
3. Latch Release (Recline and Folding)
4. Backrest
5. Quick Release Rear Wheel and Tire
6. Caster Fork
7. Caster Wheel and Tire
8. Footplate
9. Removable Legrest Assembly
10. Seat Frame



NOTE: All features may not be available with some chair setups or in conjunction with another chair feature. Please consult your Sunrise Medical authorized dealer for information. Your authorized dealer can also provide you with information on accessories.

**4.0 NOTICE - READ BEFORE USE****A. CHOOSE THE RIGHT CHAIR & SAFETY OPTIONS**

Sunrise Medical provides a choice of many wheelchair styles to meet the needs of your child. However, final selection of the type of device, options, and adjustments rests solely with you and your health care provider. Choosing the best device and set-up for safety depends on such things as:

1. The child's disability, strength, balance, coordination, and the limits of their abilities.
2. The types of hazards that must be overcome in daily use (where you live and work), and other places you are likely to use the device.
3. The dependents need of options for their safety and comfort (such as positioning belts, or special seating systems).

**B. REVIEW THIS MANUAL OFTEN**

Before using this chair you, and each person who may assist you, should read this entire manual and ensure you follow all instructions. Review the warnings often, until they are second nature to you.

**C. WARNINGS** 

The word "WARNING" refers to a hazard or unsafe practice that may cause severe injury or death to you or to other persons. The "Warnings" are in three main sections, as follows:

1. 5.0 - GENERAL WARNINGS  
Here you will find a safety checklist and a summary of risks you need to be aware of before you ride this chair.
2. 6.0 - SAFETY WARNINGS: FALLS & TIP-OVERS  
Here you will learn about practices for the safe use of your chair, and how to avoid a fall or tip-over while you perform daily activities in your chair.
3. 7.0 - WARNINGS — COMPONENTS & OPTIONS  
Here you will learn about the components of your chair and options you can select for safety. Consult your Sunrise Medical authorized dealer and your health care provider to help you choose the best set-up and options for safe use.

NOTE - Where they apply, you will also find "Warnings" in other sections of this manual. Heed all warnings in these sections. If you fail to do so a fall, tip-over or loss of control may occur and cause severe injury to the rider or others.

## 5.0 GENERAL WARNINGS

### A. WEIGHT LIMIT

#### WARNING

NEVER exceed the weight limit specified by Sunrise Medical. The weight capacity provided by your manufacturer is for the combined weight of a rider and items carried using on-board storage. If you do exceed the weight limit, damage to your chair, a fall, tip-over or loss of control may occur and cause severe injury to the rider or others.

#### Weight Capacity

Zippie Sphynx - 250 lbs/(113kg)

### B. INTENDED USE

The Zippie Sphynx wheelchair's intended use is to provide mobility to persons limited to a sitting position.

#### WARNING

DO NOT use this device for purposes other than what is intended by the manufacturer.

1. The wheelchair is not designed for weight training and is unsafe for use as a seat while weight training. Weight training from the wheelchair substantially changes the stability of the chair and may cause tipping.
2. DO NOT stand on the frame of the wheelchair.
3. NEVER allow someone to stand on your chair or use it as a step ladder.
4. This chair is designed for a single rider only.
5. Unauthorized modifications and use of parts or accessories not supplied or approved by Sunrise Medical may change the chair structure. This will void the warranty and may cause a safety hazard. If the warning is ignored, damage to your chair, and the potential for severe injury of the person using the chair for unintended purposes can occur.

### C. ATTENDANTS AND CAREGIVERS

#### WARNING

Before you assist a rider, ensure you read all warnings contained in this manual, and follow all instructions that apply. Be aware that after consulting a health care provider, you will need to learn safe and proven body mechanics to use and create assistive methods best suited to your abilities.

1. Work with the child's health care provider to learn safety methods best suited to your abilities and those of your child.
2. To prevent injury to your back, use good posture and proper body mechanics when lifting, or tilting your child.
3. When you descend a curb or single step, slowly lower the mobility device in one easy movement.
4. NEVER leave the dependent child alone.
5. When making adjustments to the mobility device, always engage the hub lock to help minimize unintended movement.

### D. ACCESSORIES

#### WARNING

Unauthorized modifications or use of parts, or accessories not supplied or approved by Sunrise Medical may change the chair structure. This will void the warranty and may cause a safety hazard.

Some problems that may occur, but are not limited to:

1. Incorrect wheels and/or tires that put the rider at risk of a fall or tip-over.
2. Adding a component to the frame, changing the structural integrity of the chair.
3. Any modification or disassembly can potentially create an unsafe situation where rider and/or attendant are put at risk.

### E. KNOW YOUR CHAIR

#### WARNING

Every wheelchair is different. Take the time to learn the feel of this chair before you begin riding. Start slowly, with easy, smooth strokes. If you are used to a different chair, you may use too much force and tip over. If you use too much force, damage to your chair, a fall, tip-over or loss of control may occur and cause severe injury to the rider or others.

### F. REDUCE THE RISK OF AN ACCIDENT

#### WARNING

1. BEFORE you begin riding, you should be trained in the safe use of this chair by your health care provider.
2. Practice bending, reaching and transfers until you know the limit of your ability. Have someone help you until you know what can cause a fall or tip-over and how to avoid doing so.
3. Be aware that you must develop your own methods for safe use best suited to your level of function and ability.
4. NEVER try a new maneuver on your own. Ask the advice of your health care provider to lower the risk of a fall or tip over.
5. Get to know the areas where you plan to use your chair. Look for hazards and learn how to avoid them.

If you fail to heed these warnings, damage to your chair, a fall, tip-over or loss of control may occur and cause severe injury to the rider or others.

### G. SAFETY CHECKLIST

#### WARNING

Before Each Use Of Your Chair:

1. Ensure the chair rolls easily and that all parts work smoothly. Check for noise, vibration, or a change in ease of use. This may indicate loose fasteners, or damage to your chair.
2. Immediately repair any problem. Your Sunrise Medical authorized dealer can help you find and correct the problem(s).
3. Check to see that both quick-release rear axles are locked. When locked, the axle button will "pop out" fully. If not locked, the wheel may come off and cause you to fall.
4. Never seat the child in the wheelchair until it is fully unfolded and locked.
5. Always use a pelvic positioning belt while the child is seated.
6. Never leave your child unattended.

### H. CHANGES & ADJUSTMENTS

#### WARNING

1. If you modify or adjust this chair, it may increase the risk of a tip-over UNLESS you make other adjustments as well.
2. Consult your Sunrise Medical authorized dealer BEFORE you modify or adjust your chair.
3. Unauthorized modifications by the end-user, dealer or any other individual, including the use of parts not supplied or approved by Sunrise Medical, may change the chair structure. This will void the warranty and may cause a safety hazard.

If you fail to heed these warnings, damage to your chair, a fall, tip-over or loss of control may occur and cause severe injury to the rider or others.

### I. ENVIRONMENTAL CONDITIONS

#### WARNING



1. Use extra care if you must ride your chair on a wet or slick surface. If you are in doubt, ask for help.
2. Contact with water or excess moisture may cause your chair to rust or corrode. Avoid all extreme weather situations if possible.
  - a. Do not use your chair in a shower, pool or other body of water. The chair tubing and parts are not water-tight and may rust or corrode from the inside.
  - b. Avoid excess moisture. For example, do not leave your chair in a damp bathroom while taking a shower.
  - c. Dry your chair as soon as you can if it gets wet, or if you use water to clean it.
  - d. Avoid contact with salt or salty conditions as this may cause damage to the chair.

If you fail to heed these warnings, damage to your chair, a fall, tip-over or loss of control may occur and cause severe injury to the rider or others.

**J. TERRAIN****⚠ WARNING**

1. Based on ANSI/RESNA testing, Sunrise Medical recommends the use of a caster wheel with a minimum diameter of 5-in (127mm), if the wheelchair will be overcoming obstacles up to 1/2-in (12.7mm) on a regular basis.
2. Your chair is designed for use on firm, even surfaces such as concrete, asphalt, indoor flooring, and carpets.
3. Do not operate your chair in sand, loose soil, or over rocky terrain.
4. If you use your chair on terrain that is rougher than described above there is a danger that screws and bolts will loosen prematurely, and that damage to wheels or axles could put the rider at risk of a fall, tip-over, or loss of control.

If you fail to heed these warnings, damage to your chair, a fall, tip-over, or loss of control may occur and cause severe injury to the rider or others.

**K. STREET USE****⚠ WARNING**

1. This product is not intended for street use. Avoid streets whenever possible.
2. This product should stay in, and obey all legal pedestrian pathways, and laws that apply to pedestrians.
3. Be alert to the danger of motor vehicles in parking lots.
4. At night, or when lighting is poor, use reflective tape or clothing for maximum visibility.
5. If you have to cross a road, make eye contact with drivers before you go forward. When in doubt, yield until you are sure it is safe.

If you fail to heed these warnings, damage to your chair, a fall, tip-over, or loss of control may occur and cause severe injury to the rider or others.

**L. MOTOR VEHICLE SAFETY** 5.1 5.2**⚠ WARNING**

If possible and feasible, the rider should transfer to the Original Equipment Manufacturer vehicle seat and use the OEM vehicle restraint.

Sunrise Medical does provide a WC-19 Wheelchair Tie-Down and Occupant Restraint System, otherwise called a Transit Option. To identify whether your wheelchair has been manufactured with the Transit Option installed, look for four points of securement. Two front points (A), and two rear points (B). These points are recognized by the securement point decal which can be found on or near the securement points.

**If your wheelchair is equipped with the Transit Option, please review the Transit Securement supplement that was provided with the wheelchair for additional information and instructions. You can request a copy from your Sunrise Medical authorized dealer, or call Sunrise Medical at 1-800-333-4000 if you do not have it.**

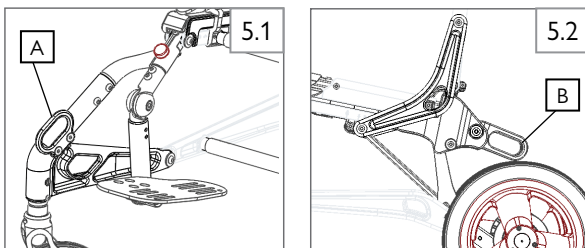

Look for this symbol on your wheelchair. It indicates wheelchair securement points which conform to ANSI/RESNA (1998) V.1 - Section 19 and/or ANSI/RESNA (2012) V.4 WC-19. For more Transit related information, see the "Transit Securement Supplement" included with your chair.

**⚠ WARNING**

If your chair is **NOT** equipped with the Transit Option:

1. NEVER let anyone sit in this chair while in a moving vehicle.
  - a. ALWAYS move the rider to an approved vehicle seat.
  - b. ALWAYS secure the rider with proper motor vehicle restraints.
3. In an accident or sudden stop the rider may be thrown from the chair. Wheelchair seat belts will not prevent this, and further injury may result from the belts or straps.
4. NEVER transport this chair in the front seat of a vehicle. It may shift and interfere with the driver.
5. ALWAYS secure this chair so that it cannot roll or shift.
6. DO NOT use any wheelchair that has been involved in a motor vehicle accident. A sudden stop and/or collision may structurally damage your wheelchair. There may have been a change to the structure of the chair, and/or damaged or broken some of the components. Inspect for: visual cracks, dents, metal distortion, bends, or damage to the seating mounting. If the wheelchair has been involved in an accident, discontinue use immediately and contact your Sunrise Medical authorized dealer for a thorough inspection. Work with the dealer to determine if the device is still safe to use if it has been involved in a collision. If damage is questionable or if there is concern regarding the condition of the chair, Sunrise Medical recommends replacement of the chair.

NOTE- The warranty is void on any wheelchair that is involved in a collision.

If you fail to heed these warnings, damage to your chair, a fall, tip-over, or loss of control may occur and cause severe injury to the rider or others.

**M. WHEN YOU NEED HELP****⚠ WARNING**

**For The Rider:** Ensure that each person who helps you reads and follows all warnings and instructions that apply.

**For Attendants:**

1. Work with the rider's doctor, nurse, or therapist to learn safe methods best suited to your abilities and those of the rider.
2. Tell the rider what you plan to do, and explain what you expect the rider to do. This will put the rider at ease and reduce the risk of an accident.
3. Ensure the chair has push handles. They provide secure points for you to hold the rear of the chair to prevent a fall or tip-over. Check to ensure push handle grips will not rotate or slip off.
4. To prevent injury to your back, use good posture and proper body mechanics. When you lift or support the rider or tilt the chair, bend your knees slightly and keep your back as upright and straight as you can.
5. Remind the rider to lean back when you tilt the chair backward.
6. When you descend a curb or single step, slowly lower the chair in one easy movement. Do not let the chair drop the last few inches to the ground. This may damage the chair or injure the rider.
7. Whenever you aren't attending the wheelchair, ALWAYS use the wheel-lock to secure the rear wheels if you must leave the rider alone, even for a moment. This will reduce the risk of a tip-over or loss of control of the chair.

If you fail to ask for help when in doubt, you run a high risk of a fall, tip-over, or loss of control that may occur and cause severe injury to the rider or others.

**N. CHOKING HAZARD****⚠ WARNING**

NOTE- Your chair consists of many small parts that could present a choking or swallowing hazard to young children. Take care to keep loose parts out of reach when doing any work on the chair. Seek immediate help if a loose part is swallowed by a child.

**O. PINCH POINT****⚠ WARNING**

NOTE- Your wheelchair has many moving parts that can create pinch points and possible finger traps. Be aware when making any adjustments, when folding and unfolding, when moving, and any other situation that could cause a pinch point situation.



## 6.0 SAFETY WARNINGS: FALLS & TIP-OVERS

### A. CENTER OF BALANCE

#### WARNING

Dependent mobility devices are designed for stability and performance. The point where this device will tip forward, back, or to the side depends on its center of balance and stability. The center of balance is also affected by:

1. The seat height and seat angle.
2. Backrest angle.
3. Changes in your child's body position, postures, or weight distribution.
4. Pushing the mobility device on a ramp or slope.
5. The use of a backpack or other options, and the amount of added weight.
6. The use of vents, batteries, oxygen, and other options, and the amount of added weight that these options add to the device.

#### To maintain the proper center of gravity and good balance:

1. Consult your health care provider and/or Sunrise Medical authorized dealer to help you in setting up the mobility device correctly.
2. Consult your Sunrise Medical authorized dealer or health care provider BEFORE you modify or adjust the mobility device. Be aware that you may need to make other changes to correct the center of balance.
3. Never hang items greater than 5 lbs (2.3kg) from stroller handle or seat back handle.

If you fail to heed these warnings, you are at a high risk of a fall, tipover, or loss of control that could cause severe injury to the rider or others.

### B. DRESSING OR CHANGING CLOTHES

#### WARNING

Your child's weight may shift if they dress or change clothes while seated in this chair.

To reduce the risk of a fall or tip-over:

1. Rotate the front casters until they are as far forward as possible. This makes the chair more stable.
2. Back the chair up against a wall and lock both rear wheels.

If you fail to heed these warnings, you are at a high risk of a fall, tipover, or loss of control that could cause severe injury to the rider or others.

### C. OBSTACLES

#### WARNING

Riding over curbs or obstacles can cause tipping and serious bodily harm. If you have any doubt that you can safely cross any curb or obstacle, ALWAYS ASK FOR HELP. Be aware of your riding skills and personal limitations. Develop new skills only with the help of a companion.

To avoid the risk of traversing obstacles:

1. Keep a lookout for danger – scan the area well ahead of your chair as you ride.
2. Ensure the floor areas where you live and work are level and free of obstructions.
3. Remove or cover threshold strips between rooms.
4. Install a ramp at entry or exit doors. Ensure there is not a drop off at the bottom of the ramp.
5. To Help Correct Your Center Of Balance:
  - a. Lean your upper body FORWARD slightly as you go UP over an obstacle.
  - b. Press your upper body BACKWARD as you go DOWN from a higher to a lower level.
3. Do not go over an obstacle without help.
4. Never push or pull on an object (such as furniture or a doorjamb) to propel your chair.

If you fail to heed these warnings, you are at a high risk of damage to your chair, a fall, tip-over, or loss of control may occur and cause severe injury to the rider or others.

### D. FRONT CASTER LIFT

#### WARNING

Front caster lift can occur when the front wheels, ordinarily in contact with the ground, are either intentionally, or unintentionally caused to lift from the ground while the rear wheels remain in contact. Pitch control (partial or full) should NEVER be attempted without consulting your health care provider.

If you fail to heed these warnings damage to your chair, a fall, tip-over, or loss of control may occur and cause severe injury to the rider or others.

### E. REACHING OR LEANING

#### WARNING

If your child reaches or leans it will affect the center of balance of the chair. This may cause a fall or tip over. When in doubt, they should ask for help or use a device to extend their reach.

1. NEVER allow your child to reach or lean if they must shift their weight sideways or rise up off the seat.
2. NEVER allow your child to reach or lean if they must move forward in their seat to do so. Your child should always keep their buttocks in contact with the backrest.
3. NEVER allow your child to reach with both hands. They may not be able to catch themselves to prevent a fall if the chair tips.
4. NEVER allow your child to reach or lean to the rear.
5. DO NOT allow your child to reach or lean over the top of the seat back. This may damage one or both backrest tubes and cause them to fall.
6. If your child must reach, move the mobility device as close as you can to the object, and rotate the front casters until they are as far forward as possible.
7. Note — To do this: Move your mobility device past the object that the child might want to reach, then back up alongside it.

If you fail to heed these warnings damage to your chair, a fall, tip-over, or loss of control may occur and cause severe injury to the rider or others.

### F. MOVING BACKWARD

#### WARNING

Use extra care when you move your chair backward. Your chair is most stable when you propel yourself forward. You may lose control or tip over if one of the rear wheels hits an object and stops rolling.

1. Propel your chair slowly and smoothly.
2. Stop often and check to ensure your path is clear.

If you fail to heed these warnings damage to your chair, a fall, tip-over, or loss of control may occur and cause severe injury to the rider or others.

## G. ESCALATORS

### ⚠ WARNING

**NEVER use this chair on an escalator, even with an attendant. If you do, a fall or tip-over is likely.**

If you fail to heed these warnings damage to your chair, a fall, tip-over, or loss of control may occur and cause severe injury to the rider or others.

## H. RAMPS, SLOPES & SIDEHILLS 6.1 6.2 6.3 6.4

### ⚠ WARNING

Whenever possible, avoid riding on a slope, which includes a ramp or sidehill. This will change the center of balance of your chair. Your chair is less stable and more difficult to maneuver when it is at an angle.

1. **DO NOT** use your chair on a slope steeper than 6°. A 6° slope means: one foot in elevation for every ten feet of slope length.
2. **ALWAYS** go as straight up and as straight down as you can. Do not “cut the corner” on a slope or ramp.
3. **DO NOT** turn or change direction on a slope.
4. When you have to use a ramp, always stay in the **CENTER** of the ramp. Ensure ramp is wide enough that you have no risk of going off the edge.
5. **DO NOT** stop on a steep slope. If you stop, you may lose control of your chair.
6. **NEVER** use rear wheel locks to try to slow or stop your chair. This is likely to cause your chair to veer out of control.
7. **ALWAYS** be aware of:
  - a. Wet or slippery surfaces.
  - b. A change in grade on a slope (or a lip, bump, or depression). These may cause a fall or tip-over.
  - c. A drop-off at the bottom of a slope or ramp. A drop-off as small as 3/4 inch (19mm) can stop a front caster and cause the chair to tip forward.
8. To Reduce The Risk Of A Fall Or Tip-Over:
  - a. Lean or press your body **UPHILL**. This will help adjust for the change in the center of balance caused by the slope or sidehill.
  - b. **ASK FOR HELP** any time you are in doubt.
9. Ramps At Home & Work– For your safety, ramps at home and work must meet all legal requirements for your area:
  - a. **AVOID A DROP-OFF:** Ensure there is a section at the top or bottom to smooth out the transition.
  - b. **ALWAYS** stay in the center of the ramp and control your speed.

If you fail to heed these warnings damage to your chair, a fall, tip-over, or loss of control may occur and can possibly cause severe injury to the rider or others.

#### For Attendants:

Follow these steps to help the rider go up or down a ramp:

1. Stay behind the chair.
2. Firmly grasp the push handles.
3. For going up or down a ramp, the chair should always be facing forward.

If you fail to heed these warnings damage to your chair, a fall, tip-over, or loss of control may occur and cause severe injury to the rider or others.



**IF you need to go down a hill:**

- a. The Downslope should be less than 6°
- b. **GO SLOW Control your speed**
- c. **ALWAYS** Go Straight down
- d. **NEVER** turn on a hill
- e. **ALWAYS** lean backward

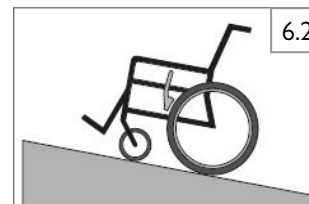

**IF you need to go up a hill:**

- a. The Upslope should be less than 6°
- b. **ALWAYS** Go Straight up
- c. **DON'T STOP**
- d. **NEVER** turn on a hill
- e. **ALWAYS** lean forward

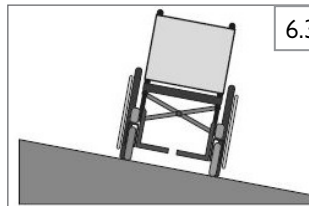

**IF you need to traverse a Sidehill:**

- a. Sidehill must be less than 6° or you are risking a tip over
- b. **DON'T STOP**
- c. **NEVER** turn on a hill

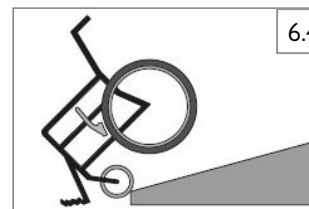

**IF you need to traverse a Ramp:**

- a. **Go Slowly**
- b. **Watch out for Drop-offs**
- c. **ALWAYS** Go Straight Up or Straight Down
- d. **Stay centered on the Ramp**



## 6.0 SAFETY WARNINGS: FALLS & TIP-OVERS

### I. TRANSFERS 6.5 6.6

#### WARNING

It is dangerous to transfer on your own. It requires good balance and agility. Be aware that there is a point during every transfer when the wheelchair seat is not below you.

To avoid a fall:

1. Work with your health care advisor to learn safe transfer methods.
  - a. Learn how to position your body and how to support yourself during a transfer.
  - b. Have someone help you until you know how to do a safe transfer on your own.
2. Lock the rear wheels before you transfer.
3. Be aware that the chair can still slide and/or tip. The wheel lock keeps the rear wheels from rolling while you are performing the transfer.
4. Move your chair as close as you can to the seat you are transferring to. If possible, use a transfer board.
5. Rotate the front casters until they are as far forward as possible.
6. If you can, remove the footrests, or swing them out of the way.
  - a. Ensure your feet do not catch in the space between the footrests.
  - b. Avoid putting weight on the footrests as this may cause the chair to tip.
7. Ensure armrests are removed, or out of the way and do not interfere with the transfer.
8. Transfer as far back onto the seat surface as you can. This will reduce the risk that the chair will tip or move away from you.

If you fail to heed these warnings damage to your chair, a fall, tip-over, or loss of control may occur and can possibly cause severe injury to the rider or others.

#### Optimum Transfer position



#### Before transferring:

1. Flip back, or remove the armrests out of the way.
2. Swing away, or remove the footrests out of the way.
3. Ensure the wheel lock is set.

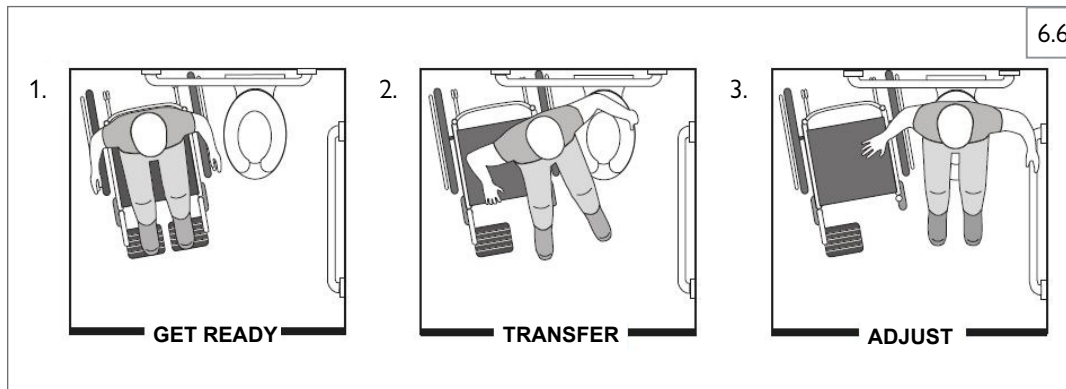

### J. CURBS & SINGLE STEPS 6.7

#### WARNING

Before riding over curbs, and negotiating even a single step, ALWAYS ask for assistance first. Curbs and steps can cause tipping and serious bodily harm. When in doubt as to your ability to avoid, or traverse any obstacle, always ask for help. Be aware of your riding skills and personal limitations. Develop new skills only with the help of a companion.

**For Attendant:** Each person who assists the rider with curbs and steps should read and follow all instructions and warnings pertaining to attendants, and caregivers.

1. Do not try to climb a high curb or step (more than 4 inches [101mm] high) UNLESS you have help. Doing so may cause your chair to exceed its balance point and tip over.
2. With the help of an attendant, go straight up and straight down a curb or step. If you climb or descend at an angle, a fall or tip-over is likely.
3. Be aware that the impact of dropping down from a curb or step can damage your chair or loosen fasteners.

If you fail to heed these warnings damage to your chair, a fall, tip-over, or loss of control may occur and can possibly cause severe injury to the rider or others.

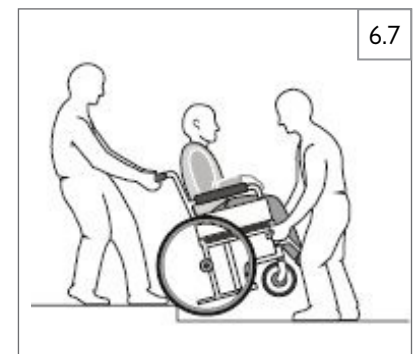

**K. CLIMBING A CURB OR SINGLE STEP** 6.7**⚠ WARNING**

**For Attendant:** follow these steps to help the rider climb a curb or single step going BACKWARD:

1. Stay behind the chair.
2. Continue backward until the rear wheels contact the face of the curb or step. Lift and roll the rear wheels to the top of the curb.
3. Pull the chair backwards until the caster wheels have cleared the edge of the curb and return the chair to its rolling position.

If you fail to heed these warnings damage to your chair, a fall, tip-over, or loss of control may occur and cause severe injury to the rider or others.

**L. DESCENDING A CURB OR SINGLE STEP** 6.7**⚠ WARNING**

**For Attendant:** Follow these steps to help a rider descend a curb or single step going FORWARD:

1. Stay at the rear of the chair.
2. Several feet before you reach the edge of the curb or step, tip the chair slightly and pull it backward.
3. When the chair is at its balance point, carefully step forward until the rear wheels reach the edge of the curb or step. Then allow the rear wheels to slowly roll down onto the lower level.
4. Push the chair forward until you are standing on the lower level.
5. When the rear wheels are safely on the lower level, tilt the chair back to its balance point.

If you fail to heed these warnings damage to your chair, a fall, tip-over, or loss of control may occur and cause severe injury to the rider or others.

**M. STAIRS** 6.8**⚠ WARNING**

1. NEVER use this chair on stairs UNLESS you have someone to help you. Doing so is likely to cause a fall or tip-over.
2. Negotiating stairs with a wheelchair always requires at least two attendants for safety.

If you fail to heed these warnings damage to your chair, a fall, tip-over, or loss of control may occur and cause severe injury to the rider or others.

**N. CLIMBING STAIRS** 6.8**⚠ WARNING**

1. Use at least two attendants to move a chair and rider up stairs.
2. Move the chair and rider BACKWARD up the stairs.
3. The person at the rear is in control. He or she tilts the chair back to its balance point.
4. A second attendant at the front firmly grasps a non-detachable part of the front frame and lifts the chair up and over one stair at a time.
5. The attendants move to the next stair up. Repeat for each stair, until you reach the landing.

If you fail to heed these warnings damage to your chair, a fall, tip-over, or loss of control may occur and cause severe injury to the rider or others.

**O. DESCENDING STAIRS** 6.8**⚠ WARNING**

1. Use at least two attendants to move a chair and rider down stairs.
2. Move the chair and rider FORWARD down the stairs.
3. The person at the rear is in control. He or she tilts the chair to the balance point of the rear wheels and rolls it to the edge of the top step.
4. A second attendant stands on the third step from the top and grasps the chair frame. He or she lowers the chair one step at a time by letting the rear wheels roll over the stair edge.
5. The attendants move to the next stair down. Repeat for each stair, until you reach the landing.

If you fail to heed these warnings damage to your chair, a fall, tip-over, or loss of control may occur and cause severe injury to the rider or others.



6.8

## 7.0 WARNINGS: COMPONENTS AND OPTIONS

### A. ARMRESTS

#### ⚠ WARNING

Armrests flip up and will not bear the weight of this chair.

1. NEVER lift this chair by its armrests. They may come loose or break.
2. Lift this chair only by non-detachable parts of the main frame.

If you fail to heed these warnings damage to your chair, a fall, tip-over, or loss of control may occur and cause severe injury to the rider or others.

### B. CUSHIONS & SLING SEATS

#### ⚠ WARNING

1. Zippie sling seats and standard foam cushions are not designed for the relief of pressure.
2. If you suffer from pressure sores or if you are at risk that they will occur, you may need a special seat system or a device to control your posture. Consult your doctor, nurse or therapist to find out if you need such a device for your well-being.
3. Seat slings are not intended to be used as a direct seating surface. A cushion or other seating surface should be placed on the sling before use.

If you fail to heed these warnings, damage to your chair, a fall, tip-over, or loss of control may occur and cause severe injury to the rider or others.

### C. FASTENERS

#### ⚠ WARNING

Many of the screws, bolts, and nuts on this chair are special high-strength fasteners. Use of improper fasteners may cause your chair to fail.

1. ONLY use fasteners provided by a Sunrise Medical authorized dealer (or ones of the same type and strength, as indicated by the markings on the heads).
2. Over- or under-tightened fasteners may fail or cause damage to chair parts.
3. If bolts or screws become loose, tighten them as soon as you can.

NOTE- For safety and optimum performance, do not reuse fasteners.

If you fail to heed these warnings damage to your chair, a fall, tip-over, or loss of control may occur and cause severe injury to the rider or others.

### D. FOOTRESTS

#### ⚠ WARNING

1. At the lowest point, footrests should be AT LEAST 2 inches (51mm) off the ground. If set too LOW, they may “hang up” on obstacles you can expect to find in normal use. This may cause the chair to stop suddenly and tip forward.
2. To Avoid A Trip Or Fall When You Transfer:
  - a. Ensure your feet do not “hang up” or get caught in the space between the footrests.
  - b. Do not put weight on the footrests, as the chair may tip forward.
  - c. Footrests should be swung out of the way or removed whenever entering or exiting the wheelchair.
3. NEVER lift this chair by the footrests. Footrests detach and will not bear the weight of this chair. Lift this chair only by non-detachable parts of the main frame.
4. Never use the footrests of your chair to open doors, this may cause them to fail prematurely and create an unsafe situation.

If you fail to heed these warnings damage to your chair, a fall, tip-over, or loss of control may occur and cause severe injury to the rider or others.

### E. POSITIONING BELTS (Option)

#### ⚠ WARNING

Use positioning belts ONLY to help support the rider's posture. They can be used to limit slipping and/or sliding that you might experience when the chair is in motion. The positioning belt is not a transit rated safety belt and should not be used in the place of a seat belt while being transported in a motor vehicle. Improper use of positioning belts may cause severe injury or death. If you use a positioning belt, be sure to follow the recommendations in this section:

1. Ensure the rider does not slide down in the wheelchair seat. If this occurs, the rider may suffer chest compression or suffocate due to pressure from the belts.
2. The belts must be snug, but must not be so tight that they interfere with breathing. You should be able to slide your open hand, flat, between the belt and the rider.
3. A pelvic wedge or a similar device can help keep the rider from sliding down in the seat. Consult with the rider's doctor, nurse, or therapist to find out if the rider needs such a device.
4. Use positioning belts only with a rider who can cooperate. Ensure the rider can easily remove the belts in an emergency.
5. NEVER use positioning belts
  - a. As a patient restraint. A restraint requires a doctor's order.
  - b. On a rider who is comatose or agitated.
  - c. As a motor vehicle restraint. In an accident or sudden stop the rider may be thrown from the chair. Wheelchair positioning belts will not prevent this, and further injury may result from the belts or straps.

If you fail to heed these warnings, damage to your chair, a fall, tip-over, or loss of control may occur and cause severe injury to the rider or others.

### F. PUSH HANDLES 7.1

#### ⚠ WARNING

Ensure that this chair has push handles.

1. Push handles provide secure points for an attendant to hold the rear of this chair, to prevent a fall or tip-over.
2. Check to ensure push handle grips (A) will not rotate or slip off.

If you fail to heed these warnings damage to your chair, a fall, tip-over, or loss of control may occur and cause severe injury to the rider or others.

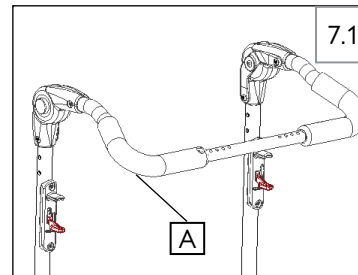

### G. QUICK-RELEASE AXLES

#### ⚠ WARNING

1. Do not use this chair UNLESS you are sure that both quick-release rear axles are locked.
2. An axle is not locked until the quick-release button pops out fully. If the axle is not inserted fully, the wheel may come off during use, endangering the rider.
3. Quick-Release Axles should be periodically cleaned and inspected for function and signs of wear or bending. Replace as necessary.

If you fail to heed these warnings damage to your chair, a fall, tip-over, or loss of control may occur and cause severe injury to the rider or others.

**H. REAR WHEEL HUB LOCK****⚠ WARNING**

Rear wheel locks are NOT designed to slow or stop a moving wheelchair. Use them only to keep the rear wheels from rolling when your chair is at a complete stop.

1. NEVER use rear wheel locks to try to slow or stop your chair when it is moving. Doing so may cause a fall or tip-over.
2. To keep the rear wheels from rolling, always engage the hub lock when you transfer to or from your chair.

If you fail to heed these warnings damage to your chair, a fall, tip-over, or loss of control may occur and cause severe injury to the rider or others.

**I. MODIFIED SEAT SYSTEMS****⚠ WARNING**

Use of a seat system not approved by Sunrise Medical may alter the center of balance of this chair. This may cause the chair to tip over.

1. Do not change the seat system of your chair UNLESS you consult your Sunrise Medical authorized dealer first.
2. Use of a seating system not approved by Sunrise Medical may affect the folding mechanism of this chair.

If you fail to heed these warnings damage to your chair, a fall, tip-over, or loss of control may occur and cause severe injury to the rider or others.

**J. SEAT AND BACK UPHOLSTERY****⚠ WARNING**

1. Replace worn or torn fabric of seat and seat back as soon as you can. If you fail to do so, the seat or seat back may fail.
2. Sling fabric will weaken with age and use. Look for fraying, thin spots, or stretching of fabrics especially at edges and seams.
3. "Dropping down" into your chair will weaken fabric and result in the need to inspect and replace the seat more often.
4. Be aware that laundering or excess moisture will reduce the flame retardation qualities of the fabric.
5. If Tension Adjustable upholstery is present, loosen straps or remove upholstery prior to folding or unfolding the chair.

If you fail to heed these warnings damage to your chair, a fall, tip-over, or loss of control may occur and cause severe injury to the rider or others.

**K. STROLLER HANDLE****⚠ WARNING**

1. Always keep hands away from the locking mechanism located at the bottom of the back canes when folding the back down or pulling it back up.
2. Always keep fingers away from the interior of the hinge when readjusting the adjustable stroller handle.

**L. TRAY FOR VENT AND BATTERY****⚠ WARNING**

Never use this wheelchair as a seat in a motor vehicle unless all components are removed from the battery tray, and properly secured separately in the vehicle.

**⚠ WARNING**

Always contact Technical Service before installing or removing the battery tray components to obtain the correct assembly locations of the strut tubes.

**⚠ WARNING**

The combined weight of the user plus the ventilator, battery and tray components should not exceed 250 lbs (114 kg).

**M. ACCESSORY HOOK****⚠ WARNING**

**The weight limit for the accessory hook is 10 lbs (4.5 kg) (total) for all items.**

If you fail to heed these warnings damage to your chair, a fall, tip-over, or loss of control may occur and cause severe injury to the rider or others.

## 8.0 USE AND MAINTENANCE

### WARNING

The owner and/or Caregiver of this chair is responsible for ensuring that it has been set up and adjusted by a trained service professional under the advice of a health care provider. The chair may require periodic safety and function checks or certain tool free adjustments that can be performed by the owner, caregiver, or Sunrise Medical authorized dealer, if desired. Always use parts and/or accessories that have been recommended or approved by Sunrise Medical when servicing this chair.

### A. INTRODUCTION

- Proper maintenance will improve performance and extend the useful life of your chair.
- Clean your chair regularly. This will help you find loose or worn parts and make your chair easier to use. You will need a mild detergent solution and plenty of cleaning rags.
- If discovered, repair or replace loose, worn, bent, or damaged parts **before using the chair**. ALWAYS be sure to use Parts and/or accessories that have been recommended or approved by Sunrise Medical.
- To protect your investment, have all major maintenance and repair work done by your Sunrise Medical authorized dealer.
- Inspect and maintain this chair strictly per the Maintenance Chart.**
- If you detect a problem, make sure to order parts, or have service and repair work done at your Sunrise Medical authorized dealer before use.**
- At least once per year, have a complete inspection, safety check, and service of your chair made by a Sunrise Medical authorized dealer.**

### B. CRITICAL MAINTENANCE TIPS

- Axles & Axle Sleeves:**  
When checking axles and axle sleeves every six months, ensure they are clean and tight. Loose sleeves will damage the axle plate and will affect performance.

### C. CLEANING TIPS

- Paint Finish**
  - Clean the painted surfaces with mild soap or detergent at least once a month.
  - Protect the paint with a coat of non-abrasive auto wax every three months.
- Axles and Moving Parts**
  - Clean around axles and moving parts WEEKLY with a slightly damp (not wet) cloth.
  - Wipe off or blow away any fluff, dust, or dirt on axles or moving parts.
- Upholstery**
  - Hand-wash (machine washing may damage fabric).
  - Drip-dry only. DO NOT machine dry as heat will damage fabric.
- Basic Maintenance Materials available at local store**
  - Clean rags or cotton cloth
  - Teflon®-based lubricant
  - Mild detergent
  - Silicone spray lubricant

**NOTE** - You do not need to grease or oil the chair.

### D. MAINTENANCE CHART

Weekly	Monthly	3 Months	6 Months	Annually	Safety & Function Check
<input checked="" type="checkbox"/>					Hub Lock
	<input checked="" type="checkbox"/>				Visually check for loose hardware
			<input checked="" type="checkbox"/>		Armrests
			<input checked="" type="checkbox"/>		Axle and Axle Sleeves
		<input checked="" type="checkbox"/>			Quick-release Axles
		<input checked="" type="checkbox"/>			Wheels and Tires
		<input checked="" type="checkbox"/>			Casters
			<input checked="" type="checkbox"/>		Frame, Folding & Recline Mechanism
	<input checked="" type="checkbox"/>				Upholstery
				<input checked="" type="checkbox"/>	<b>Service by Sunrise Medical authorized dealer</b>

NOTE - The user or caregiver should perform these weekly and monthly checks to maintain the safety of their chair. If an item is not working properly, please contact your Sunrise Medical authorized dealer.

### E. TROUBLESHOOTING CHART

Symptoms					Solution
	Squeaks and rattles	Difficulty folding/unfolding	Difficulty adjusting recline	Difficulty engaging latch handle	
<input checked="" type="checkbox"/>					Ensure all nuts and bolts are tight.
<input checked="" type="checkbox"/>					Use Tri-Flow Lubricant (Teflon® based) between frame connections and parts
		<input checked="" type="checkbox"/>			Ensure seating and positioning components are not obstructing or interfering with the folding mechanism <b>OR</b> Remove seating systems before folding
		<input checked="" type="checkbox"/>			Add silicone spray lubricant to underside of seat rail
			<input checked="" type="checkbox"/>		Add silicone spray lubricant to underside of seat rail <b>AND</b> Ensure end user is not leaning on backrest while trying to recline
			<input checked="" type="checkbox"/>		Remove latch handle cover and use Tri-Flow Lubricant (Teflon® based) on the inner wall of the backrest tube

**F. TO MOUNT AND REMOVE REAR WHEELS** 8.1**⚠ WARNING**

Do not use this chair UNLESS you ensure both quick-release axles are locked. An unlocked axle may come off during use and cause a fall.

**1. To Install Wheel**

- Depress quick-release button (A) fully. This will release tension on ball bearings at other end.
- Insert axle (B) through hub of rear wheel.
- Keep button (A) depressed as you slide axle (B) into axle sleeve (C).
- Release button to lock axle in axle sleeve. Adjust axle if it does not lock. See 9.0, Section D.
- Repeat steps on other side.

NOTE– Axle is not locked until the quick-release button (A) pops out fully.

**2. To Remove Wheel**

- Depress quick-release button (A) fully.
- Remove wheel by sliding axle (B) completely out of axle sleeve (C).
- Repeat steps on other side.

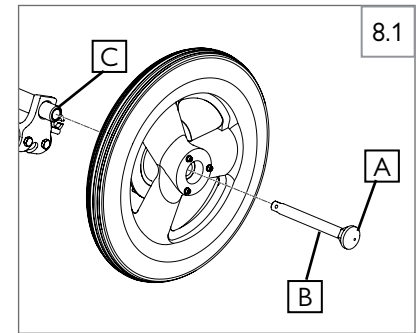
**G. HUB LOCK** 8.2**⚠ WARNING**

**Do not attempt to use the hub lock rod or lever (A) as a tipping lever. Using the hub lock rod or lever as a tipping device may result in damage to the chair.**

Hub lock is set up at Sunrise Medical and should be adjusted by your Sunrise Medical authorized dealer.

Inspect hub lock weekly per the maintenance chart. Do not use your chair UNLESS you ensure both sides of the hub lock rod can fully engage the hub lock discs. Ensure that both hub lock extension springs are attached. A wheel lock that is not properly engaging may allow your chair to roll or turn unexpectedly.

- To engage the hub lock, lift up on the red hub lock rod pedal (A) with your foot. If needed, roll the chair forward or rearward slightly while lightly lifting on the pedal with your foot to help the rod engage the discs.
- To disengage the hub lock, gently press down on the red hub lock rod pedal (A) with your foot.

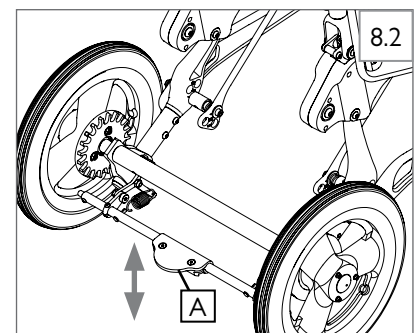
**H. ADJUSTABLE LOCKING FLIP-UP ARMRESTS** 8.3**1. Flip up and down**

- Release the upper securing lever (2).
- Flip the armrest (1) back, it remains attached to the back post.
- Move armrest down into place.
- The lever (2) locks itself in position automatically.

**⚠ WARNING**

**Armrest should not be used for lifting or carrying the wheelchair. Always check that the armrests are correctly engaged. There is a risk of trapping fingers when adjusting the armrests.**

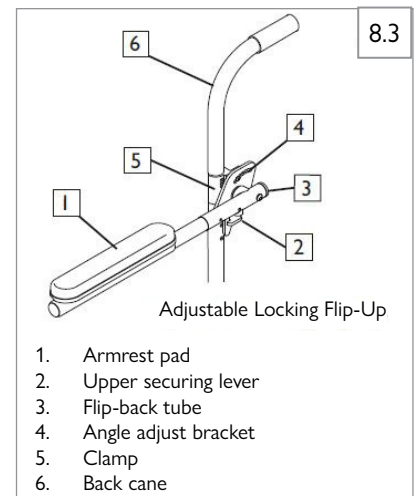
**I. FOOTRESTS, LEGRESTS, & FOOTPLATES** 8.4

Ensure that your Sunrise Medical authorized dealer has correctly adjusted your footrests and/or legrests with the advice of a health care provider. The original setup should not be changed without first checking with that advisor. The footrest position is key to keeping your body in the proper alignment, and providing a stable support for your legs and torso. Legrests and footrests should be swung out of the way, or removed for transfers.

**Removing Legrest/Footplate Assemblies:**

- Remove thumbscrew (A) to detach legrest/footrest assembly from chair. The thumbscrew will remain attached to the frame on the lanyard.
- Repeat on opposite side of chair.

**⚠ WARNING**

- The footrests are not designed to be used to lift or carry the wheelchair with an occupant.
- When getting into or out of the chair, never stand on the foot boards.
- There is a risk of trapping fingers when flipping the footrest up or down.

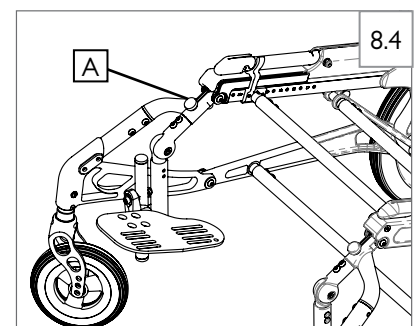



## 8.0 USE AND MAINTENANCE

### J. BACKREST UPHOLSTERY

1. Backrest Upholstery:  
Check monthly for excessive stretching of the upholstery, or loose attaching hardware. If you determine the upholstery is no longer tight, contact your Sunrise Medical authorized dealer for a replacement.

### K. TENSION ADJUSTABLE UPHOLSTERY 8.5 8.6 8.7 8.8 8.9 8.10 8.11 8.12

#### Adjusting Standard Tension Adjustable Backrest Upholstery

1. Ensure the dependent is not seated in the mobility device before adjusting the backrest upholstery.
2. Remove vanity flap. (Fig 8.7)
3. Straps should be adjusted when chair is unfolded.
4. DO NOT over tighten straps, as this will cause undue strain upon the chair frame.
5. Adjust straps to desired tightness. (Fig 8.5)
6. If straps need to be replaced:
  - a. Attach top strap first, cut to length.
  - b. Mount short side of backrest straps to back post (A). (Fig 8.8)
  - c. Mount long side of backrest straps on the opposite side (B). (Fig 8.9)
  - d. Mount crocodile fixator (C) (Fig 8.10). Fixator should be placed in the middle of the strap (D & E), trim as needed. (Fig 8.11 & Fig 8.12)
5. Attach backrest cover and fold over rear of hook and loop strapping system. The Zippie patch should be upright on the rear of the chair. (Fig 8.7)
6. Finish set up by placing vanity flap (center panel) down onto hook and loop tension adjustable straps to secure attachment.

#### **WARNING**

Any changes made to the straps will affect the center of gravity. It is best to have the attendant stationed behind the wheelchair to prevent the wheelchair from tipping backwards while the user becomes accustomed to the adjustment.

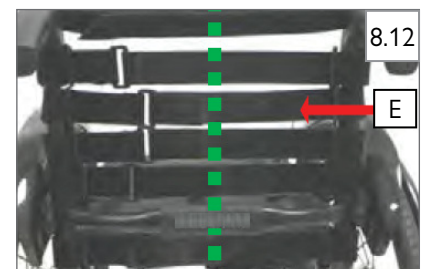
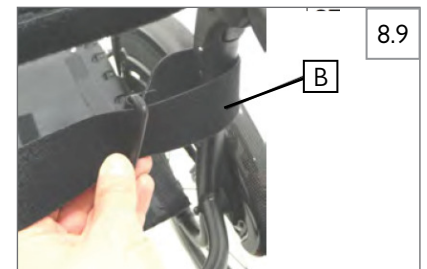

**L. SEATING AND SEAT SLING UPHOLSTERY** 8.13**1. Seat Sling Upholstery**

- Check monthly for excessive stretching of the upholstery, or loose attaching hardware. If you determine the upholstery can no longer be adjusted tight, contact your Sunrise Medical authorized dealer for a replacement.

**2. Cushion Attachment**

- Place cushion on the seat sling with loop material side down. The beveled edge of the cushion should be facing toward the front of your chair. Cushion will fold over the front of the seat sling and attach to the hook patches underneath the seat sling. (Fig. 8.13)
- Press firmly into place.

**⚠ WARNING**

Loose or worn seat slings may sag to a point that they contact chair components positioned under the seating surface. Using the chair in this condition may lead to pressure related injuries.

**M. ADJUSTING RECLINE ANGLE (Back to Seat angle)** 8.14 8.15 8.16

- Pull both latch handles halfway up until they contact the recline stop tab as shown in Fig 8.14. While holding the latch handles in this position, pull or push the backrest to your desired back-to-seat angle.
- Check the recline angle marking on the side of the seat frame to ensure you are at the desired angle. Possible back-to-seat angles are 85°, 90°, 95°, and 100°. (Fig 8.15)
- Confirm that recline angle is positioned at the same setting on both sides of the chair.

**⚠ WARNING**

Ensure both recline latch pins are fully engaged. If not fully engaged, lightly rock backrest back and forth until fully engaged. (Fig 8.16)

**⚠ WARNING**

Do not attempt to recline the backrest with the latch handle in the folding position, as you may inadvertently unlock the frame. If this happens and the frame is not returned to the lock position, completely fold and unfold the frame to return it to the lock position. Always check that the tilt link front pivot is in the lock position as indicated on the seat frame prior to use. (Fig 8.15)

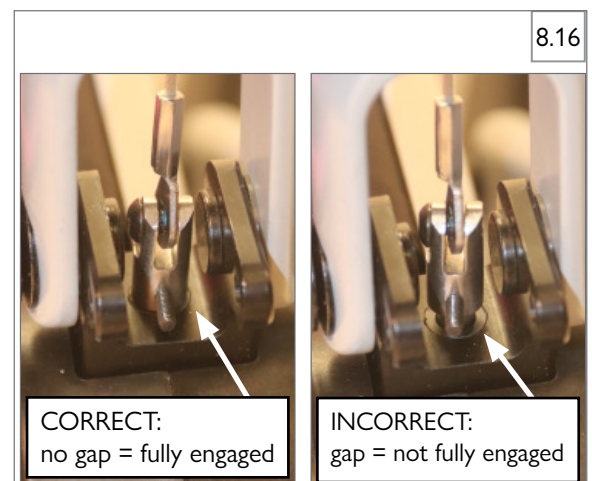
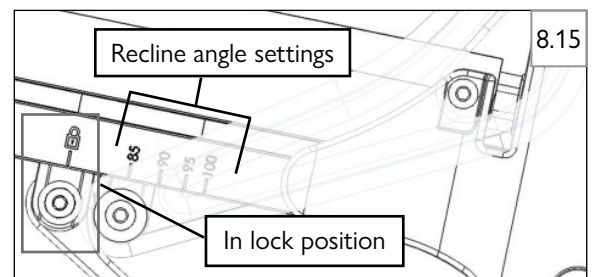
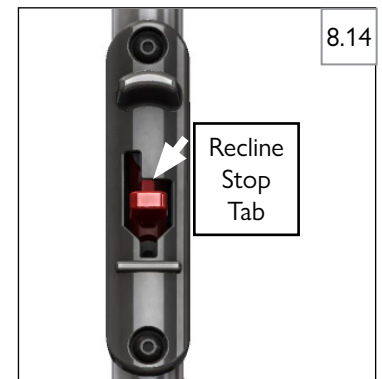

## 8.0 USE AND MAINTENANCE

### N. FOLDING AND UNFOLDING

8.17 8.18 8.19 8.20

#### 1. Unfolding the chair:

- With the chair on the ground, pull the backrest up by the stroller handles until you hear the audible click and the backrest clicks into the first recline position of 85°.
- Ensure that the front pivot of the tilt link is in the locked position indicated on each side of the chair. Check that chair is in 85° recline. (Fig 8.17)

#### **⚠ WARNING**

Ensure that the front slide is in its fully locked position by checking that the locked position mark on either side of the seat frame is aligned with the pivot point of the front slide. Always perform this check after using the latch handle and before returning the chair to use. (Fig 8.17)

#### **⚠ WARNING**

Check that backrest pin is fully engaged on both sides of chair. (Fig 8.20)

#### 2. Folding the chair:

- Pull both latch handles all the way up by shifting the handles past the recline stop tab (Fig 8.18). While holding the handles in this position, push the backrest until the chair begins to fold.
- Release the latch handles while continuing to fold until the backrest bottoms out on the seat.**
- Secure strap to keep chair in folded position. (Fig 8.19)

#### **⚠ WARNING**

Be careful not to get your fingers caught in the cross-tube assembly during folding and unfolding.

**The latch handles will naturally return to position during the folding process. As a result, you should let go of the latch handles after the chair has begun folding; do not attempt to resist the latch handles' tendency to return to position as you fold the chair.**

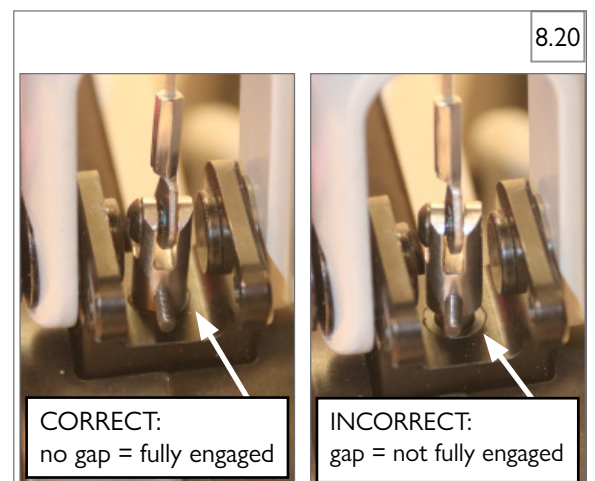
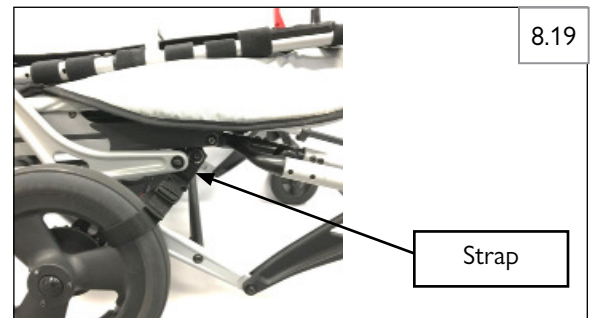
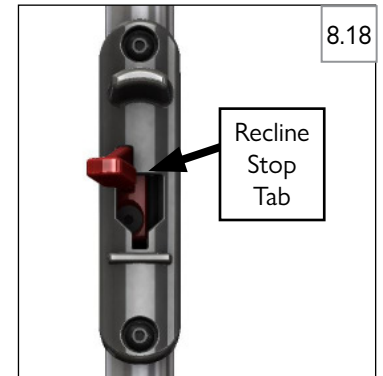
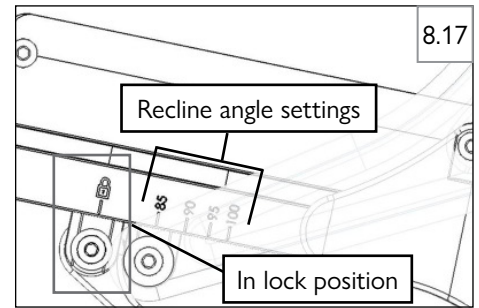

**O. FOLDING ANGLE ADJUSTABLE PUSH HANDLES** 8.21

- Loosen push handle (A) by pushing the black buttons on both sides of the chair (B). You can then raise or lower the push handle to the desired position.

NOTE - For easy storage and portability, lower the push handles all the way to fold flat.

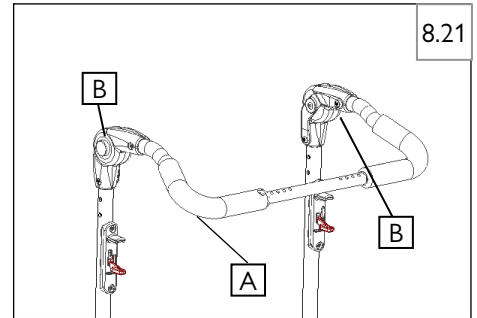
**P. CANOPY ATTACHMENT AND ADJUSTMENT** 8.22 8.23**⚠ WARNING**

It is always best to ensure the dependent is not seated in the mobility device during the attachment of accessories.

**1. Attaching the Receivers to the Frame**

- Snap each receiver to the backrest tube in any available space above the towel bar. Ensure that both snaps on each receiver are securely attached to the backrest tubes.

**2. Attaching the Canopy to the Receivers**

- From behind your mobility device, attach the canopy to the receivers (A).
- Check that the canopy has been attached correctly by visual inspection and checking for looseness, or an incorrect attachment. The plastic tabs (B) must be locked into place for safe operation.

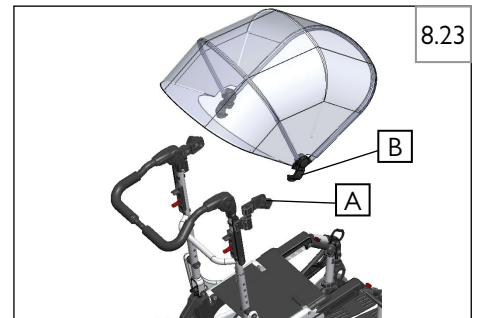
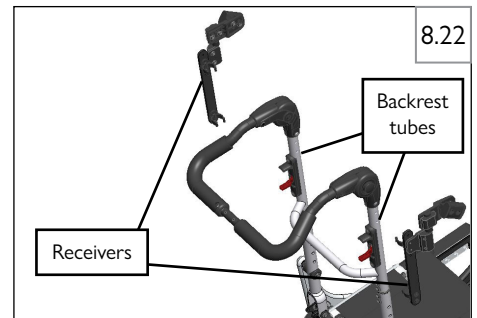
**Q. STORAGE TIPS**

- Store your chair in a clean, dry area. If you fail to do so, parts may rust or corrode.
- Before using your chair, ensure it is in proper working order. Inspect and service all items on the "Maintenance Chart".
- If stored for more than three months, have your chair inspected by a Sunrise Medical authorized dealer before use.

**R. INSPECT**

After the wheelchair is assembled and adjusted, it should roll smoothly and easily. All accessories should also perform smoothly. If you have any problems, follow these procedures:

- Review the set-up and check-out sections and operating guide to ensure the chair was properly prepared.
- Review troubleshooting guide.
- If your problem persists, contact your Sunrise Medical authorized dealer. If you still have a problem after contacting your authorized dealer, contact Sunrise Medical customer service. See the introduction page for details on how to contact your authorized dealer or Sunrise Medical customer service.

## 9.0 DEALER SERVICE & ADJUSTMENT

### WARNING

The owner of this chair is responsible for ensuring that it has been setup and adjusted by a trained service professional under the advice of a health care provider. Service and/or adjustments should only be done with the advice of a health care provider. Always use parts and/or accessories that have been recommended and approved by Sunrise Medical when servicing this chair. Service and/or adjustments that require the use of tools should only be done by a Sunrise Medical authorized dealer under the advice of a health care provider.

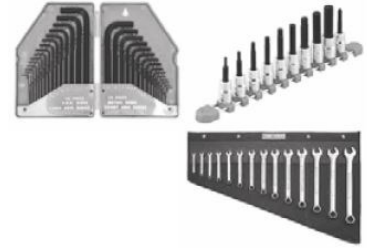

### A. DEALER SERVICE INTRODUCTION

1. At least once per year, this chair should have a complete inspection, safety check, and regular service made by a Sunrise Medical authorized dealer. The tool list at right is a good starting point for proper maintenance.
2. Torque settings – A torque setting is the optimum tightening which should be made on a particular fastener. It is important to use proper torque settings where specified.
3. If you have discovered a worn, bent, or damaged part(s), repair or replace them with recommended parts before returning this chair to service.
4. All major maintenance and repair work should be done by the Sunrise Medical authorized dealer.

#### TOOLS YOU WILL NEED

1. Imperial Hex key set
2. Metric Hex key set
3. Imperial Open-end Wrench set
4. Metric Open-end Wrench set
5. Torque wrench
6. Imperial Hex bit Socket set
7. Metric Hex bit Socket set
8. Phillips and Flat screwdrivers
9. Rubber mallet

### B. CRITICAL MAINTENANCE TIPS

#### 1. Torque settings:

A torque setting is the optimum tightening which should be made on a particular fastener. It is important to use proper torque settings where specified. When not specified, torque settings should be: M5 fasteners = 5 Nm [44 in-lbs], M6 fasteners = 7 Nm [62 in-lbs], M8 fasteners = 10 Nm [88 in-lbs]. For all others torque setting should be 6.8 Nm [60 in-lbs]. All joints secured with threaded fasteners will relax over time resulting in an actual torque that is lower than the initial torque setting. This is especially applicable for joints with elastic components.

#### 2. Dealer Service and Adjustment Reference materials:

Go to [www.SunriseMedical.com](http://www.SunriseMedical.com) for parts manuals, instruction sheets, and instructional videos that will aid in the repair of your Zippie wheelchair.

### C. CLEANING

1. Paint Finish
  - a. Clean the painted surfaces with mild soap or detergent.
  - b. Protect the paint with a coat of non-abrasive auto wax.
2. Axles and Moving Parts
  - a. Clean around axles and moving parts with a slightly damp (not wet) cloth.
  - b. Wipe off or blow away any fluff, dust, or dirt on axles or moving parts.
  - c. DO NOT USE 3-in-ONE oil, or WD-40® for lubrication. Only use Teflon® based lubricant when working on this wheelchair.

### D. REAR WHEEL AXLE NUT ADJUSTMENT 9.1

#### 1. Rear Wheel Axle Adjustment

Tight axle sleeves should be maintained for proper performance of the wheelchair.

- a. To adjust the axle (C) you will need a 3/4-in wrench to turn the outside axle nuts (E).
- b. You will also need a 1/2-in wrench to lodge the ball bearings (D), on the opposite end of the axle, and prevent the axle from turning.
- c. Turn the outside axle nut (E) clockwise to tighten.
- d. There should only be zero to ten thousandths of an inch (.010-in) of play.

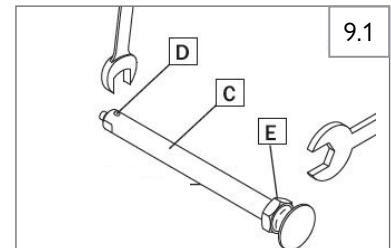



**E. ADJUSTABLE LOCKING FLIP-UP ARMRESTS** 9.2**1. Height Adjustment**

- Loosen bolts (B) and remove bolts (C).
- Move the clamp (D) up or down to the desired position. Holes for bolt C need to align with backrest tube holes.
- Attach again bolts (C) and tighten bolts (B).
- Repeat the process for the other armrest.

Note: Clamp can be oriented up or down to obtain 1/2-in increments of height adjustment.

**2. Angle-Adjustment**

- Remove bolt (E).
- Set armrest at desired angle using preset holes in armrest angle plate (A).
- Replace bolt (E).
- Repeat the process for the other armrest.

**3. Length-Adjustment (optional)**

- Loosen the nut and screw (F) in the adjustable flip-up tube (G).
- Reposition the sleeve (G) at the desired length.
- Tighten again the screw (F) and nut.
- Repeat the process for the other armrest.

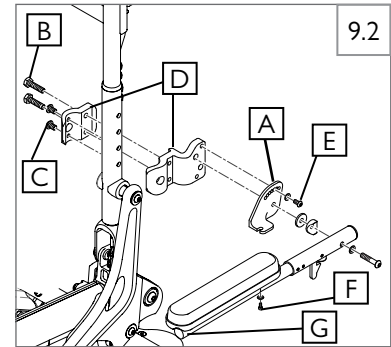
**F. ANGLE ADJUSTABLE HANGERS AND FOOTRESTS****1. Hanger Angle Adjustment** 9.3 9.4

Recommended hanger angle adjustment range is 120° to 180°.

- Adjust knuckle above footrest (A) using 6mm allen wrench.
- Remove lower half of legrest knuckle and reattach at desired angle.
- Replace screw and torque to 16.3 Nm [144 in-lbs].
- Repeat on opposite side of chair.

NOTE: adjusting the hanger angle may affect the legrest length.

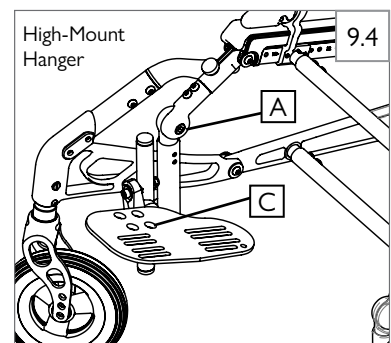
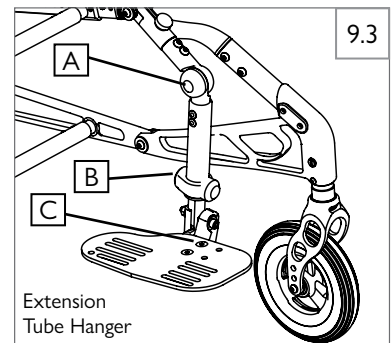
**2. Extension Tube Hanger Length Adjustment** 9.3

- Loosen screw (B) on back of clamp using 3/16-in allen wrench.
- Slide hanger to desired length.
- Tighten screw (B) on back of clamp using 3/16-in allen wrench.
- Torque to 16.3 Nm [144 in-lbs].
- Repeat on opposite side of chair.

**3. High Mount Hanger Length Adjustment** 9.4 9.5 9.6

- Height of footrests can be changed by adjusting high mount clamps:
  - Loosen bolts (H).
  - Adjust position of clamps (F) and/or tube (G) to achieve desired hanger length.
  - Tighten bolts (H) to 16.3 Nm [144 in-lbs].
- Further adjustment range can be achieved by switching between Up or Down orientation. (Fig 9.6)
  - Remove footplate hardware (D) and footplate assembly (E). Remove clamp (F) and hardware.
  - Flip tube (G) over. Attach again using clamp (F) and hardware.
  - Attach again footplate assembly (E) and footplate hardware (D).

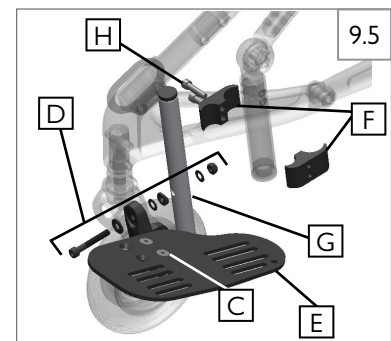
**4. Aluminum Angle Adjustable Footplate** 9.3 9.4 9.5

- Using a 3/16-in allen wrench, loosen footplate fasteners (C).
- Reposition footplate in new angular position. Using a 3/16-in allen wrench, tighten fasteners.
- Repeat on opposite side of chair.

NOTE– Maintain a minimum of 2.0 inches (50.8 mm) between the lowest point on the footrest and the floor.

**⚠ WARNING**

Do not stand on the footplate during transfer. The chair is likely to tip to the front when standing on the footplate. Always place your feet securely on the ground for transferring into or out of the chair.

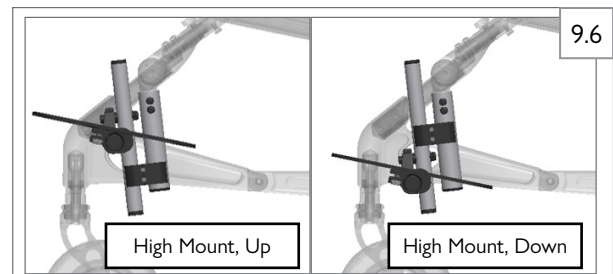



## 9.0 DEALER SERVICE & ADJUSTMENT

### G. BACKRESTS 9.7 9.8 9.9

#### Backrest Cable Adjustment

If there is too much play in the latch handle or if the latch pin clevis is not fully engaged, the cable needs to be adjusted.

1. Using a 3mm allen wrench, remove two bolts (A) from the cover (B). (Fig 9.7)
2. On top side of the recline rod, use a 3mm allen wrench on bolt C and at the same time insert a 2mm allen wrench into slot (D) of the recline rod (E). (Fig 9.8)  
Note: you may need to rotate the recline rod (E) to make the slot accessible.
3. To decrease tension, increase cable length by loosening bolt C slightly.
4. To increase tension, decrease cable length by tightening bolt C slightly.
5. Place cover (B) on the latch handle and ensure that the latch pin clevis is fully engaged. (Fig 9.9)
6. If latch pin adjustment is incorrect, repeat steps 1-5.
7. Repeat for opposite side of the chair.

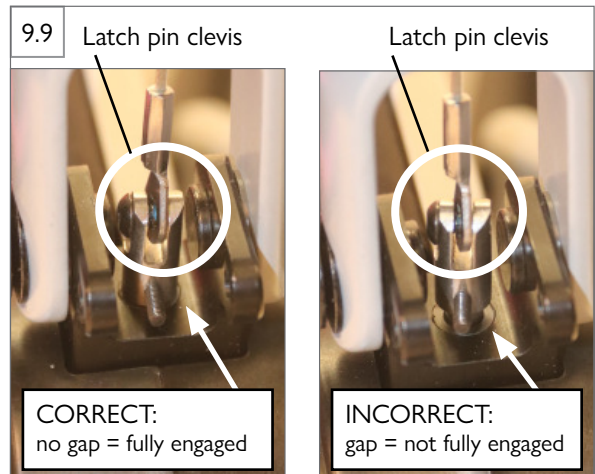
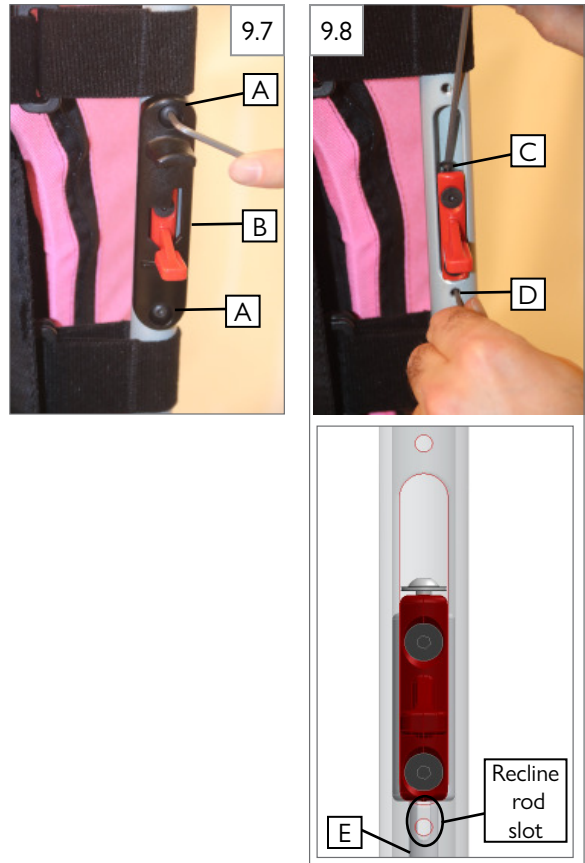

## H. SEAT SLING TENSION ADJUSTMENT

### Front Seat Sling Tension Adjustment

9.10 9.11 9.12 9.13 9.14 9.15 9.16

1. Remove seat cushion.
2. Remove seat rail end caps (A). (Fig 9.10)
3. Starting on one side of the chair, remove nut (D) with a 10mm wrench while securing bolt (B) with a 4mm Allen. Next, remove bolt (B) (Fig 9.11). Repeat for the other side of the chair. Note: If bolt (B) is difficult to remove, relieve the seat sling tension on the bolt by turning the telescoping seat tube slightly outward with a 6mm Allen wrench inserted as shown. (Fig 9.14)
4. Remove front seat sling (C) and seat sling rods. (Fig 9.12)
5. Adjust tension by adjusting hook and loop foldover on sling.
6. Replace front seat sling and seat sling rods. Ensure front edge of seat sling and seat sling rods are flush with the telescoping seat tubes. (Fig 9.13)
7. Use a 6mm allen wrench to turn telescoping seat rail tube outward to align holes and insert bolts (B) on both sides of the chair and fasten with nuts (D). (Fig 9.14) Torque nuts (D) to 16.3 Nm [144 in-lbs] with a 10mm torque wrench while securing bolts (B) with a standard 4mm Allen wrench. **Do not attempt to use a 4mm Allen head torque wrench as this will likely damage the hex socket portion of the bolt head.**
8. Repeat steps 4-7 if desired tension is not achieved.
9. Attach seat rail end caps by starting with slot in end cap inserted into seat sling. Then, rotate outward so that channel in cap is facing up. Push end cap until it bottoms out on telescoping seat tube. (Fig 9.15 & Fig 9.16)

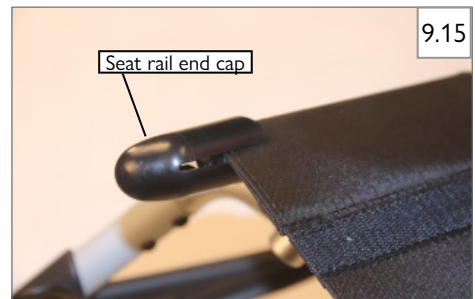
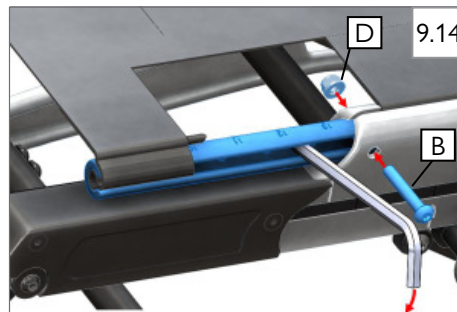
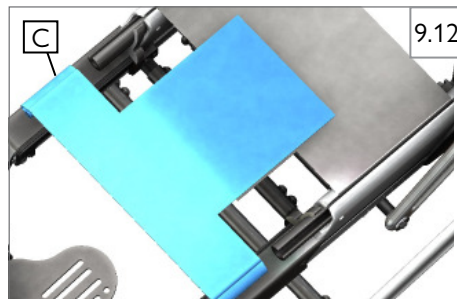
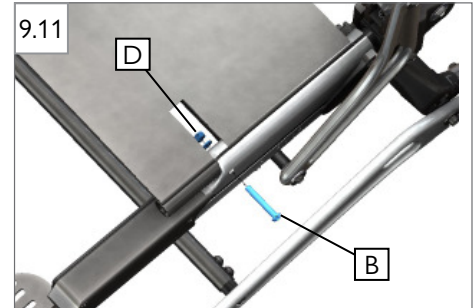
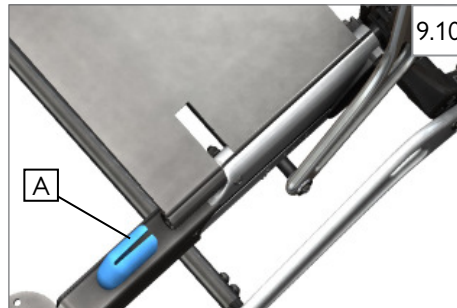

## 9.0 DEALER SERVICE AND ADJUSTMENT

## Rear Seat Sling Tension Adjustment

9.17 9.18 9.19 9.20 9.21 9.22 9.23 9.24 9.25 9.26 9.27 9.28

1. Remove seat cushion.
2. Remove front seat sling by completing steps 2-4 from Front Seat Sling Adjustment (previous page).
3. Remove telescoping seat tubes. (Fig 9.17)
4. Remove rear bolts and nuts from outer seat rail. (Fig 9.18)
5. Insert one end of a 6mm allen wrench into the tool access hole of the rear seat rail plug and rotate plug inward so that the channel faces up. Complete on both sides of chair. (Fig 9.19)
6. Remove rear seat sling and rear seat sling rods.
7. Adjust tension by adjusting hook and loop folderover on sling.
8. Replace rear seat sling and seat sling rods positioning as far back as possible, until rear seat sling bottoms out on flathead screw and rear seat rail plug bottoms out at backstop. (Fig 9.20, Fig 9.21, Fig 9.22, Fig 9.23)
9. Tighten back edge of rear seat sling:
  - a. Ensure the backrest is in the most forward recline setting (85°) to make rear bolt hole accessible.
  - b. Insert one end of a 6mm or 1/4-in allen wrench L-Key (or similar sized tool) into the tool access hole of rear seat rail plug and rotate rear plug 90° outward until its bolt hole is aligned with the hole in the outer seat rail and rear plastic covers (Figures 9.24 & 9.25).
  - c. With the holes aligned, insert bolt as shown in Fig 9.18. Do the same to the other side which should pull the rear end of the rear seat sling taut and insert the bolt while holding the sling taut, ensuring the holes are aligned.

Note: If the rear end of the seat sling is not taut, remove the seat sling and adjust the width of the sling with the hook and loop adjustment. When the rear seat sling assembly is properly attached with the desired tension, fasten nuts on to the bolts. (Fig 9.18)

10. Insert telescoping seat tubes to appropriate seat depth setting. Mark on side frame should align with mark on telescoping seat tube. (Fig 9.26)
11. Insert front seat sling and seat sling rods.
12. Turn telescoping seat tube outward to align holes and insert bolts on both sides of chair and fasten with nuts. Torque each of the two nuts to 16.3 Nm [144 in-lbs] with a 10mm torque wrench while securing bolts with a standard 4mm Allen. **Do not attempt to use a 4mm Allen head torque wrench as this will likely damage the hex socket portion of the bolt head.**
13. Attach seat rail end caps by starting with slot in end cap inserted into seat sling. Then, rotate outward so that channel in cap is facing up. Push end cap until it bottoms out on telescoping seat tube. (Fig 9.27 & Fig 9.28)

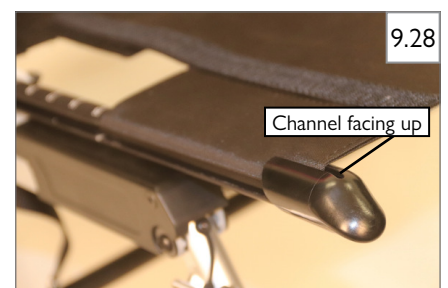
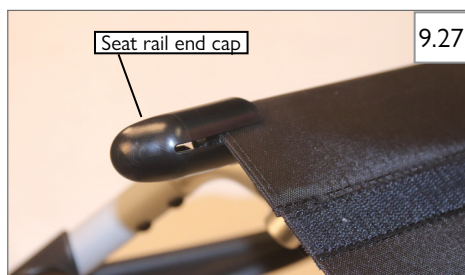
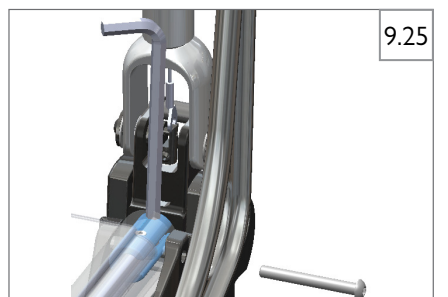
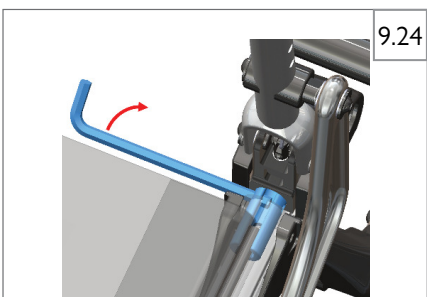
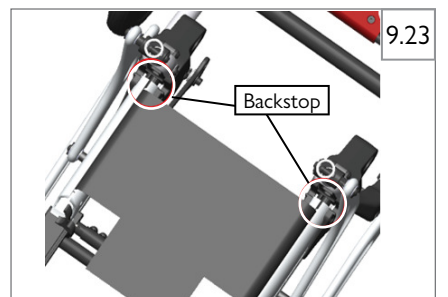
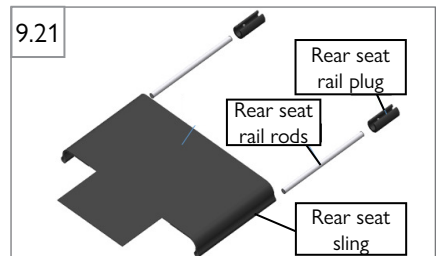
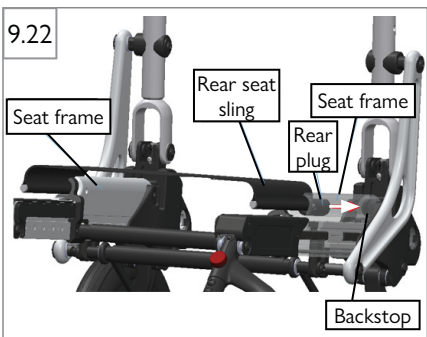
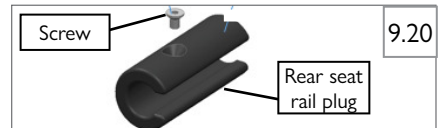
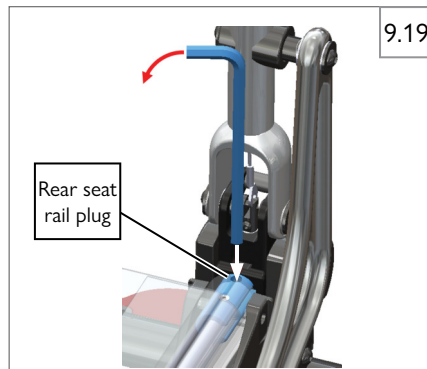
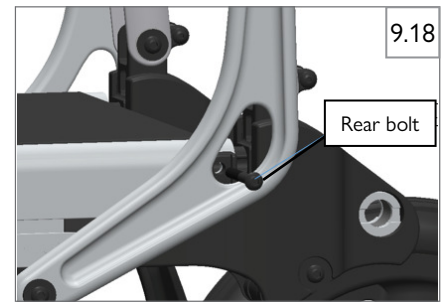
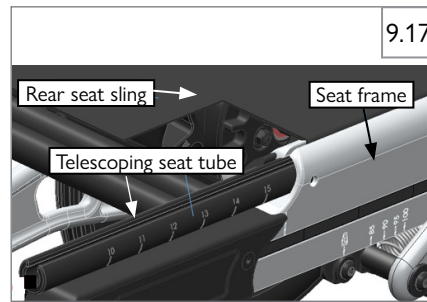
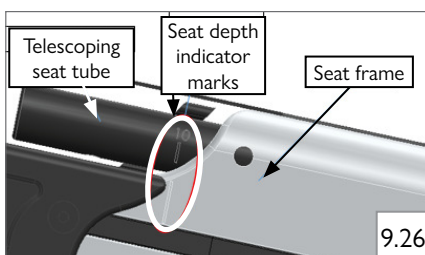



**I. ADJUSTING SEAT DEPTH**

9.29

9.30

9.31

9.32

9.33

9.34

9.35

9.36

Adjusting seat depth requires adjustment of the seat sling, seat tube, and cross tube position.

1. Remove seat cushion.
2. Remove seat rail end caps (A). (Fig 9.29)
3. Starting on one side of the chair, remove nut (H) with a 10mm wrench while securing bolt (B) with a 4mm Allen. Next, remove bolt (B) (Fig 9.30). Repeat for the other side of the chair.

Note: If bolt (B) is difficult to remove, relieve the seat sling tension on the bolt by turning the telescoping seat tube slightly outward with a 6mm Allen wrench inserted as shown in Fig 9.34.

4. Detach front seat sling loop from rear seat sling hook and pull telescoping seat tube (C) to desired depth setting using the seat depth indicator marks (D). (Fig 9.31)
5. Ensure front seat sling and front seat rail rods are flush with front edge of telescoping seat tubes.
6. Use a 2mm allen wrench to loosen set screws (E) on seat rail saddle (both sides) and move saddle up to desired setting on outer seat frame. (Fig 9.32 and Fig 9.33). Tap front upper cross tube with a mallet if needed to move saddles/cross tube forward. The front edge of each seat rail saddle (F) should align with the desired seat depth indicator mark on the seat frame (G). If your desired seat depth is 15-in or greater, move the saddles to the 15+ mark.
7. Tighten again set screws (E) on saddle with a 2mm allen wrench.
8. Rotate telescoping seat rail tubes outward to align holes. Then, insert bolts (B) on both sides of chair and fasten with nuts (H) (Fig 9.34). Torque nuts (H) to 16.3 Nm [144 in-lbs] with a 10mm torque wrench while securing bolts (B) with a standard 4mm Allen. **Do not attempt to use a 4mm Allen head torque wrench as this will likely damage the hex socket portion of the bolt head.**



9. Attach seat rail end caps by starting with slot in end cap inserted into seat sling. Then, rotate outward so that channel in cap is facing up. Push end cap until it bottoms out on telescoping seat tube. (Fig 9.35 & Fig 9.36)
10. Seat depth adjustment is complete.

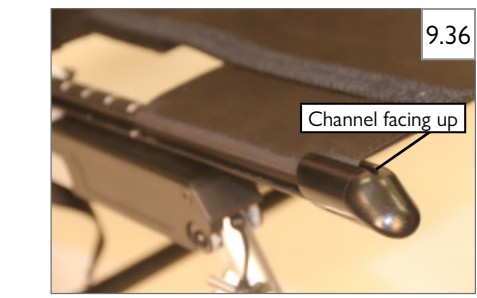
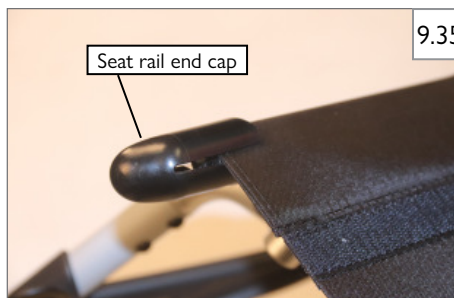
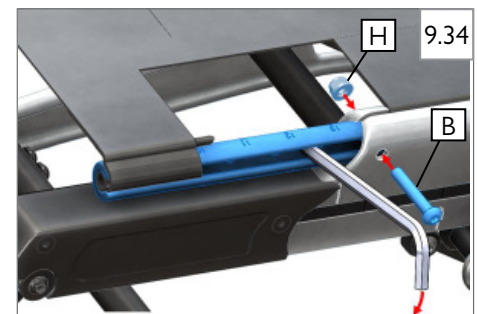
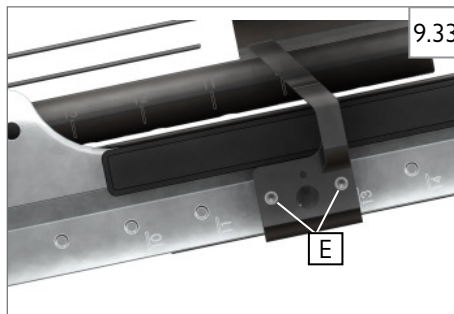
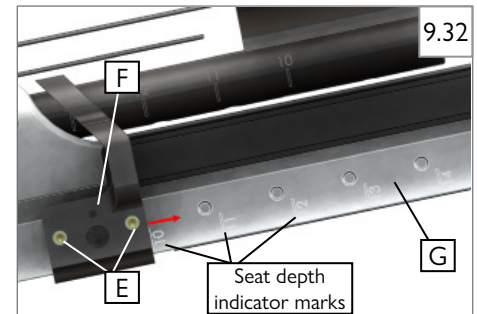
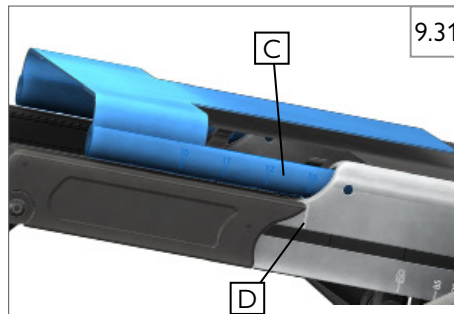
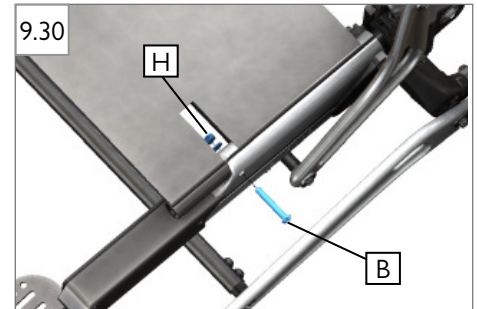
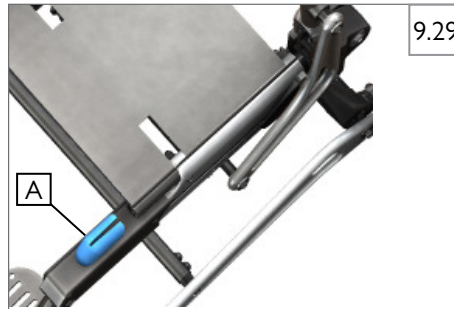

## 9.0 DEALER SERVICE AND ADJUSTMENT

## J. ADJUSTING TILT ANGLE 9.37 9.38 9.39 9.40

### (Seat to Floor angle)

Tilt angle (seat-to-floor angle) can be adjusted to 10°, 20°, or 30°. (Fig 9.42, on next page)

#### Removing Tilt Pin

1. If adjusting tilt angle from 10/20° to 30°, or if adjusting from 30° to 10/20°, remove the rubber stopper and shaft (Fig 9.37) using two 4mm allen wrenches on the M6 button head cap screws. You may need to fold the chair slightly to take weight off the stopper prior to removal. If adjusting from 10° to 20° or from 20° to 10°, there is no need to remove the stopper.
2. Remove leg rests. Flip chair upside-down (Fig 9.38) and remove rear wheels.
3. Familiarize yourself with the tilt adjustment components shown in Fig 9.39.
4. Starting on one side of the chair, use two 5mm allen wrenches to remove either the inner or outer tilt pin bolt. Then slide the tilt pin out from the frame holes. If the tilt pin doesn't easily remove, use a mallet and 8mm allen wrench to lightly tap the tilt pin free (Fig 9.40). Be sure to keep track of the spacers, spring, and washers.
5. Repeat step 4 for the opposite side of the chair.

(continued on next page)

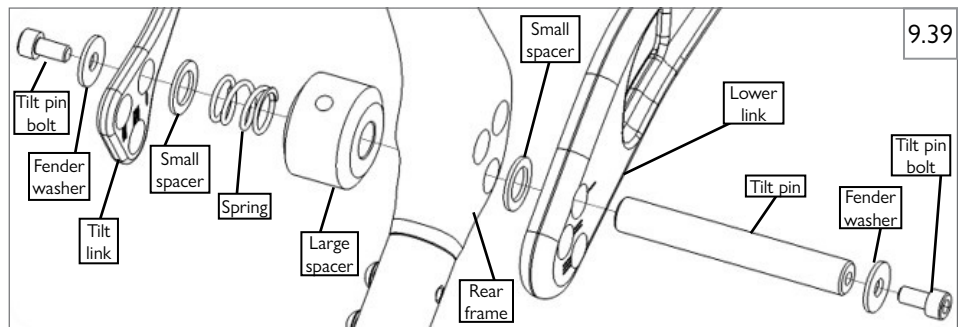
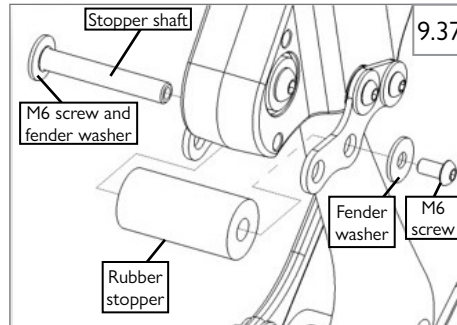



**J. ADJUSTING TILT ANGLE (Seat to Floor angle)**

(continued)

- 9.41
- 9.42
- 9.43
- 9.44
- 9.45
- 9.46

**Reattaching Tilt Pin**

1. Starting on one side of the chair, insert the tilt pin through the appropriate set of adjustment holes as shown in Figures 9.41 and 9.42. Insert the spacers and spring according to the exploded view in Figure 9.42.
2. Add the remaining fender washer and tilt pin bolt and tighten both bolts to 9 Nm [80 in-lbs] using two 5mm allen wrenches or allen wrench sockets. Ensure that the tilt pin is properly seated through the tilt link hole while tightening the bolts. 
3. Repeat steps 1-2 for the opposite side of the chair. Only perform the following steps 4-6 if adjusting the tilt angle from 10/20° to 30° or from 30° to 10/20°. If adjusting from 10° to 20° or from 20° to 10°, skip steps 4-6, reattach the rear wheels and set the chair upright.
4. Reattach the rear wheels, set the chair upright and fold partway (Figure 9.43).
5. On one side of the chair, insert the rubber stopper and shaft in the appropriate set of rear bracket holes according to Figure 9.44. Use two 4mm allen wrenches to tighten the M6 button head cap screws and fender washers to 7 Nm [62 in-lbs] (see Figure 9.37 on previous page for exploded view of components). 
6. Repeat step 5 for the opposite side of the chair. After the rubber stoppers are installed, you can fully unfold the chair (Figure 9.45).
7. It may be necessary to adjust the hub lock foot pedal angle when changing the tilt angle. Use a 3mm allen wrench to loosen screws (A) on the hub lock foot pedal. Adjust to desired angle. Tighten until hub lock foot pedal stays in place (Fig 9.46).

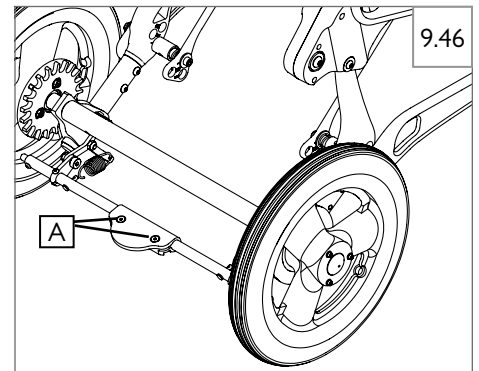
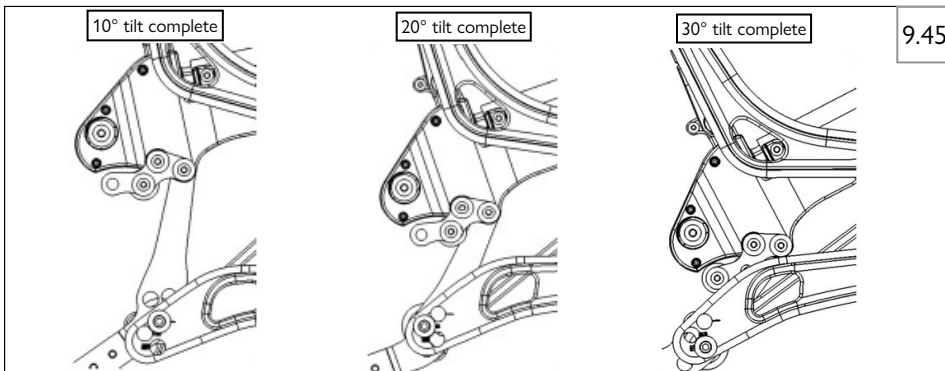
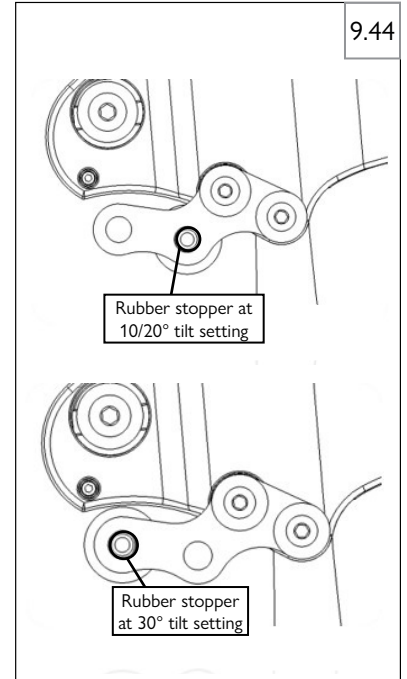
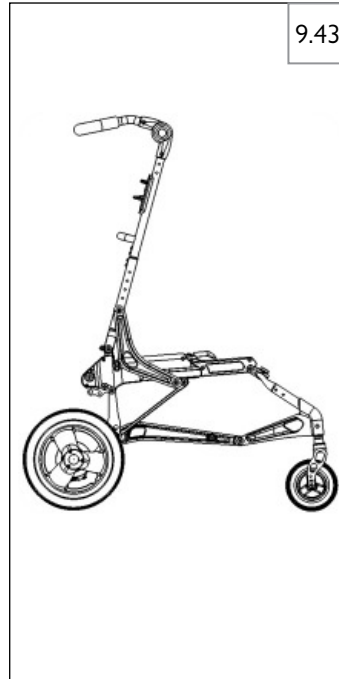
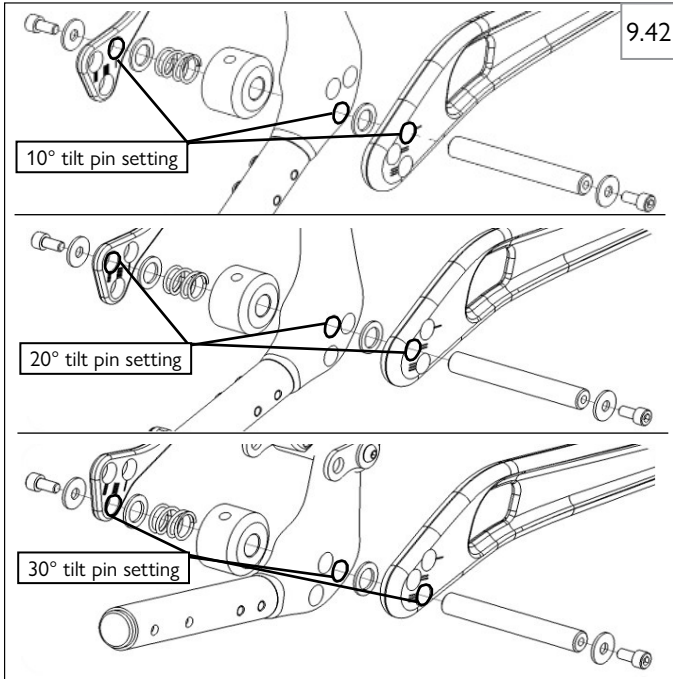
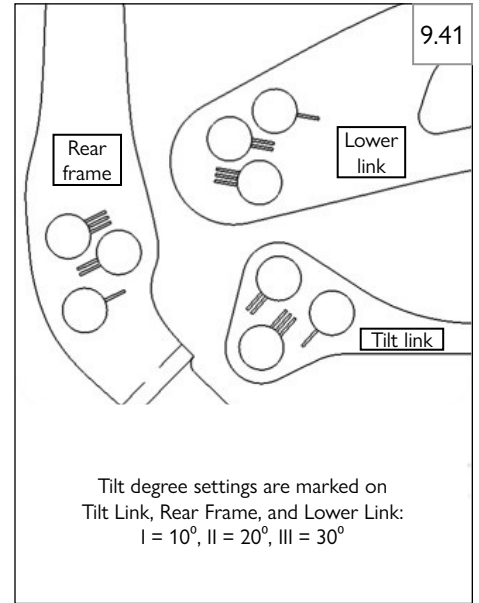



## 10.0 SUNRISE LIMITED WARRANTY

### A. FOR LIFETIME

Frame and cross-brace (if applicable) warranty:

1. Although the anticipated useful service time of this wheelchair is five years, Sunrise Medical guarantees the frame and cross brace against defects in material and workmanship for life or for as long as the original purchaser owns the chair.
2. This warranty does not apply if:
  - a. The chair is subject to abuse.
  - b. The chair is not maintained as recommended in the owner's manual.
  - c. The chair is transferred to a different person from the original owner.

### B. FOR ONE (1) YEAR

We warrant all Sunrise-made parts and components of this wheelchair against defects in materials and workmanship for one year from the date of first consumer purchase. An invoice, as proof of purchase, may be required.

Claims and repairs should be processed through the nearest Sunrise Medical authorized dealer. Except for express warranties made herein, all other warranties including implied warranties of merchantability and warranties of fitness for particular purpose are excluded. There are not warranties which extend beyond the description of the face hereof. Remedies for breach of express warranties herein are limited to repair or replacement of the goods. In no event shall damages for breach of any warranty include any consequential damages or exceed the cost of non-conforming goods sold.

### C. LIMITATIONS

1. We do not warrant:
  - a. Tires and tubes, upholstery, pads, and push-handle grips.
  - b. Damage from neglect, accident, misuse, or from improper installation or repair.
  - c. Products modified without Sunrise Medical's express written consent.
  - d. Damage from exceeding the weight limit.
2. This warranty is VOID if the original chair serial number tag is removed or altered.
3. This warranty applies in the USA and Canada only. Check with your supplier to find out if international warranties apply.
4. This warranty is not transferable and only applies to the first consumer purchase of this wheelchair through a Sunrise Medical authorized dealer.

### D. WHAT WE WILL DO

Our sole liability is to repair or replace covered parts. This is the exclusive remedy for consequential damages.

### E. WHAT AUTHORIZED DEALER MUST DO

Obtain from Sunrise Medical, while this warranty is in effect, prior approval for return or repair of covered parts. Contact Customer Service for a Returned Material Authorization (RMA) number and information as to where to return the product.

### F. NOTICE TO CONSUMER

1. You must pay the cost of labor to repair, remove, or install parts even if they are covered under warranty.
2. If allowed by law, this warranty is in place of any other warranty (written or oral, express or implied, including a warranty of merchantability, or fitness for a particular purpose).
3. This warranty gives you certain legal rights. You may also have other rights that vary from state to state or province to province.

### G. ADDITIONAL WARRANTY INFORMATION FOR AUSTRALIA ONLY

For goods provided by Sunrise Medical Pty Ltd in Australia, our goods come with a guarantee by Sunrise that cannot be excluded under the Australian Consumer Law. You are entitled to a replacement or refund for a major failure and for compensation for any other reasonably foreseeable loss or damage. You are also entitled to have the goods repaired or replaced if the goods fail to be of acceptable quality and the failure does not amount to a major failure. The benefits to you given by this warranty are in addition to your other rights and remedies under a law in relation to the goods to which the warranty relates.

Record your serial number here for future reference:

---

(Serial number label is located on the right hand side of the base frame on the inner roller plate)

Sunrise Medical S.r.l.  
Via Riva, 20 – Montale  
29122 Piacenza  
Italia  
Tel.: +39 0523 573111  
www.SunriseMedical.it

Sunrise Medical AG  
Erlenauweg 17  
CH-3110 Münsingen  
Schweiz/Suisse/Svizzera  
Tel +41 (0)31 958 3838  
www.SunriseMedical.ch

Sunrise Medical AS  
Delitoppen 3  
1540 Vestby  
Norge  
Telefon: +47 66 96 38 00  
post@sunrisemedical.no  
www.SunriseMedical.no

Sunrise Medical AB  
Neogatan 5  
431 53 Mölndal  
Sweden  
Tel.: +46 (0)31 748 37 00  
post@sunrisemedical.se  
www.SunriseMedical.se

MEDICCO s.r.o.  
H – Park, Heršpická 1013/11d,  
639 00 Brno  
Czech Republic  
Tel.: (+420) 547 250 955  
Fax: (+420) 547 250 956  
www.medicco.cz  
info@medicco.cz  
Bezplatná linka 800 900 809

Sunrise Medical Aps  
Mårkærvej 5-9  
2630 Taastrup  
Denmark  
+45 70 22 43 49  
info@sunrisemedical.dk  
www.SunriseMedical.dk

Sunrise Medical Australia  
11 Daniel Street  
Wetherill Park NSW 2164  
Australia  
Ph: +61 2 9678 6600  
Email: enquiries@sunrisemedical.com.au  
www.SunriseMedical.com.au

Sunrise Medical (US) LLC  
North American Headquarters  
12002 Volunteer Blvd.  
Mount Juliet, TN 37122, USA  
(800) 333-4000  
(800) 300-7502  
www.SunriseMedical.com



© 2025 Sunrise Medical (US) LLC  
252843 Rev. E

Sunrise Medical GmbH  
Kahlbachring 2-4  
D-69254 Malsch  
Deutschland  
Tel.: +49 (0) 7253/980-0  
Fax: +49 (0) 7253/980-222  
www.SunriseMedical.de

Sunrise Medical Ltd.  
Thorns Road  
Brierley Hill  
West Midlands  
DY5 2LD  
England  
Phone: 0845 605 66 88  
Fax: 0845 605 66 89  
www.SunriseMedical.co.uk

Sunrise Medical S.L.  
Polígono Bakiola, 41  
48498 Arrankudiaga – Vizcaya  
España  
Tel.: +34 (0) 902142434  
Fax: +34 (0) 946481575  
www.SunriseMedical.es

Sunrise Medical Poland  
Sp. z o.o.  
ul. Elektronowa 6,  
94-103 Łódź  
Polska  
Telefon: + 48 42 275 83 38  
Fax: + 48 42 209 35 23  
E-mail: pl@sunrisemedical.de  
www.Sunrise-Medical.pl

Sunrise Medical B.V.  
Defensiedok 20  
3433 NE Nieuwegein  
The Netherlands  
T: +31 (0)30 – 60 82 100  
F: +31 (0)30 – 60 55 880  
E: info@sunrisemedical.nl  
www.SunriseMedical.nl

Sunrise Medical HCM B.V.  
Vossenbeemd 104  
5705 CL Helmond  
The Netherlands  
T: +31 (0)492 593 888  
E: customerservice@sunrisemedical.nl  
www.SunriseMedical.nl  
www.SunriseMedical.eu (International)

Sunrise Medical S.A.S  
ZAC de la Vrillonnerie  
17 Rue Mickaël Faraday  
37170 Chambray-Lès-Tours  
Tel : + 33 (0) 2 47 55 44 00  
Email: info@sunrisemedical.fr  
www.SunriseMedical.fr

Sunrise Medical Canada Inc.  
1000 Creditstone Rd., Unit #2  
Concord, ON, L4K 4P8  
Canada  
Phone: 1-800-263-3390  
Fax: 1-800-561-5834  
www.SunriseMedical.ca