

Quickie[®] CAPTAIN SEAT

Supplier: This manual must be given to the user of this wheelchair.

User: Before using this wheelchair read this entire manual and save for future reference.

Owner's Manual

Quickie[®] CAPTAIN SEAT

Distribuidor: Este manual debe ser entregado el usuario de esta silla de ruedas.

Usuario: Antes de usar esta silla de ruedas, lea este manual en su totalidad y guárdelo para futura referencia.

Manual de
Instrucciones

Cada una de las sillas se envía con un manual de instrucciones en inglés. El manual en español y francés está disponible en formato PDF en nuestra página en Internet: www.SunriseMedical.com. Ingrese a la página del producto específico para descargar el manual, o comuníquese con el proveedor autorizado de Sunrise Medical.

Quickie[®] CAPTAIN SEAT

Au Fournisseur: Ce manuel doit être remis à l'utilisateur de ce fauteuil roulant.

Utilisateur: Avant d'utiliser ce fauteuil roulant, lisez l'intégralité de manuel et conserver pour référence future.

Manuel
d'instructions

Chaque fauteuil est livré avec un manuel d'instructions en anglais. Les versions en espagnol et en français sont à votre disposition en format PDF sur le site : www.SunriseMedical.com. Veuillez vous rendre à la page de votre produit pour télécharger le manuel dans la langue souhaitée, ou contactez un fournisseur agréé Sunrise Medical.

P/N 247975 Rev. C

SUNRISE MEDICAL LISTENS

Thank you for choosing a Quickie® wheelchair. We want to hear your questions or comments about this manual, the safety and reliability of your chair, and the service you receive from your Sunrise dealer. Please feel free to write or call us at the address and telephone number below:

SUNRISE MEDICAL (US) LLC
Customer Service Department
12002 Volunteer Blvd.
Mount Juliet, TN 37122, USA
(800) 333-4000



www.SunriseMedical.com/register

Be sure to register your wheelchair, and let us know if you change your address. This will allow us to keep you up to date with information about safety, new products, and options to increase your use and enjoyment of the wheelchair.

You can also register your product at:
www.SunriseMedical.com/register

FOR ANSWERS TO YOUR QUESTIONS

Your authorized dealer knows your wheelchair best, and can answer most of your questions about chair safety, use, and maintenance.

For future reference, please fill in the following:

Dealer: _____

Address: _____

Telephone: _____

Serial #: _____ Date/Purchased: _____

ADDITIONAL INFORMATION YOU SHOULD KNOW

No component of this chair was made with Natural Rubber Latex.



DISPOSAL AND RECYCLING INFORMATION

When this product reaches the end of its life, please take it to an approved collection or recycling point designated by your local or state government. This product is manufactured using a variety of materials.

Your product should not be disposed of as ordinary household waste. You should dispose of your product properly, according to local laws and regulations. Most materials that are used in the construction of this product are fully recyclable. The separate collection and recycling of your product at the time of disposal will help conserve natural resources and ensure that it is disposed in a manner that protects the environment.

Ensure you are the legal owner of the product prior to arranging for the product disposal in accordance with the above recommendations.

II. TABLE OF CONTENTS

I.	INTRODUCTION.....	2	5.0	SETTING UP THE SEATING SYSTEM	11
II.	TABLE OF CONTENTS.....	3	5.1	Pre-set leg rests and footplates (standard Captain Seat)	11
1.0	USER INFORMATION.....	4	5.2	Hanger receiver for swing away legrests (Option)	12
1.1	This user manual.....	4	5.3	Pre-set swing away legrests (Option).....	13
1.2	For further information.....	4	5.4	Swing away controller bracket	14
1.3	Symbols used in this manual.....	4	5.5	Check after setup and/or adjustment	14
2.0	SAFETY	5	5.6	Lap belt/seating positioning belt.....	15
2.1	Symbols and labels used on the product.....	5	6.0	USING THE SEATING SYSTEM.....	16
2.2	Safety: Temperature.....	5	6.1	Getting in and out of the wheelchair (Transferring)	16
2.3	Safety: Moving parts.....	5	6.2	Preparing for forward transfer.....	16
2.4	Safety: Choking hazard	5	6.3	Preparing for side transfer.....	16
2.5	Safety: General warnings.....	6	6.4	Locking pin activation.....	17
2.6	Safety: Accessory trays.....	6	6.5	Seat angle adjustment.....	18
2.7	Safety: Stability.....	6	6.6	Seat adjustment	18
3.0	GENERAL DESCRIPTION		6.7	Swing away legrests (Option).....	20
3.1	Maximum user weight.....	7	7.0	POWERED SEATING OPTIONS.....	21
4.0	WARNINGS FOR COMPONENTS AND OPTIONS.....	8	7.1	Powered seating options.....	21
4.1	Armrests	8	8.0	MAINTENANCE AND CLEANING.....	22
4.2	Cushions.....	8	8.1	General maintenance.....	22
4.3	Fasteners.....	8	8.2	Cleaning your seating system.....	22
4.4	Footplate and footrests.....	8	8.3	Hygiene measures when being re-used.....	23
4.5	Positioning belts	8	8.4	General cleaning instructions.....	23
4.6	Seating systems	8	8.5	Cleaning accessories	23
4.7	Upholstery fabric.....	8	8.6	Cleaning controls	23
4.8	Wiring and connectors.....	8	8.7	Storage.....	23
4.9	Assignable controls.....	8	8.8	Maintenance and inspection schedule.....	24
4.10	Power seating safety	9	9.0	TECHNICAL SPECIFICATIONS: APPLICABLE NORMS / STANDARDS	25
4.11	Power legrest.....	9	10.0	SUNRISE LIMITED WARRANTY	26
4.12	Lift / Tilt.....	9			
4.13	Swing away joystick arm.....	9			
4.14	Transit.....	10			

1.0 User information

Congratulations on choosing a Sunrise Medical wheelchair. Our high quality mobility products are designed to enhance your independence and make your everyday life easier.

As a part of our ongoing product improvement initiative, Sunrise Medical reserves the right to change specifications and design without notice. Further, not all features and options offered are compatible with all configurations of the wheelchair.



All dimensions are approximate and may be subject to change. The intended lifetime of the wheelchair is five (5) years. Please DO NOT use or fit any third party components to the wheelchair unless they are officially approved by Sunrise Medical.

1.1 This user manual

This user manual will help you to use and maintain your seating system safely. This seating manual is a supplement to Sunrise Medical's general wheelchair user manual:

- The general wheelchair user manual
- The user manual for the seating system (this manual)
- The user manual for the controller
- The user manual for the battery charger

When necessary, this seating user manual refers to other manuals as shown below:

-  General manual: Refers to the general user manual for the wheelchair.
-  Controller: Refers to the user manual for the controller.
-  Battery charger: Refers to the user manual for the battery charger.

Do not use your wheelchair until this entire manual (all booklets) has been read and understood!

If one of the user manuals was not included with your wheelchair, please contact your Sunrise Medical authorized dealer immediately.

1.2 For further information

Please contact your Sunrise Medical authorized dealer if you have any questions regarding the use, maintenance, or safety of your wheelchair. In case there is no authorized dealer in your area or you have any questions, contact Sunrise Medical either in writing or by telephone. For information about product safety notices and product recalls, go to www.SunriseMedical.com

1.3 Symbols used in this manual

-  **DANGER!**
Potential risk of serious injury or death
-  **WARNING!**
Potential risk of injury
-  **CAUTION!**
Potential damage to equipment
- NOTE:**
General user advice

Not following these instructions may result in physical injury, damage to the product, or damage to the environment!

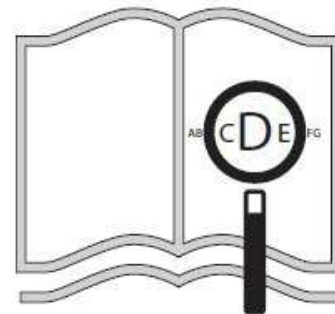

If you are visually impaired, this document can be viewed in PDF format at www.SunriseMedical.com



2.0 SAFETY

Follow the instructions carefully next to these warning symbols! Not paying careful attention to these instructions could result in physical injury or damage to the wheelchair or the environment. Wherever possible, safety information is provided in the relevant chapter.

2.1 Symbols and labels used on the product

The signs, symbols, and instructions affixed to the wheelchair comprise part of the safety facilities. They must never be covered or removed. They must remain present and clearly legible throughout the entire lifespan of the wheelchair.

Replace or repair all illegible or damaged signs, symbols, and instructions immediately. Please contact your Sunrise Medical authorized dealer for assistance.

- Fig. 2.1: Transit fixation point
- Fig. 2.2: Warning – Danger of finger entrapment (pinch point)
- Fig. 2.3: Warning – Maximum user weight for the wheelchair.
- Fig. 2.4: Ensure that the seat interface thumb screws are screwed in tight before using your wheelchair, especially on a slope.

2.2 Safety: Temperature

WARNING!

- Avoid physical contact with the wheelchair's motors at all times. Motors are continuously in motion during use and can reach high temperatures. After use, the motors will cool down slowly. Physical contact could cause burns. Allow the motors after using at least 30 minutes to cool down.
- If you do not use the wheelchair, ensure that it is not exposed to direct sunlight for lengthy periods of time. Certain parts of the wheelchair, such as the seat, the back, and the armrests can become hot if they have been exposed to full sunlight for too long. This may cause burns or allergic reactions to the skin.

2.3 Safety: Moving parts

DANGER!

A wheelchair has moving and rotating parts. Contact with moving parts may result in serious physical injury or damage to the wheelchair. Contact with the moving parts of the wheelchair should be avoided (Fig. 2.5).

- Wheels (turning and caster)
- Power tilt in space adjustment
- Power seat lift option
- Manual recline adjustment
- Swing-away bracket of the controller
- Power elevating leg rest

2.4 Safety: Choking hazard

DANGER!

This mobility aid uses small parts which under certain circumstances may present a choking hazard to young children.

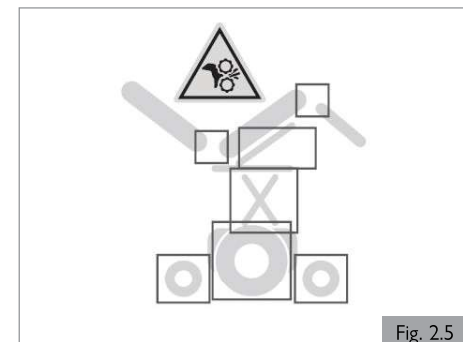
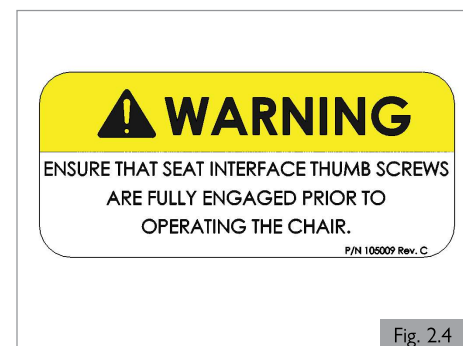
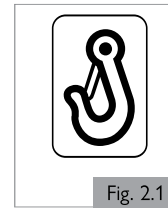

2.5 Safety: General warnings

DANGER!

1. Always ensure that you are able to operate all controls from a comfortable position. Paying attention to your posture is essential to ensure your continued comfort and well being.
2. Always ensure that you can be seen clearly. Use the lights, especially if you intend using your seating system in poor light.
3. This seating system has been set up to match the needs of a particular user. If used by another user, then it may need to be adjusted.
4. Do not let children or others use your seating system.
5. Avoid spilling liquids on to the controller or its connections, especially hot, sticky, sugary, or corrosive liquids. Such contamination may compromise the safe operation of the control system and damage the seating system upholstery.

WARNING!

DO NOT use any wheelchair that has been involved in a motor vehicle accident. A sudden stop and/or collision may structurally damage your wheelchair. There may have been a change to the structure of the chair and/or damaged or broken some of the components. Wheelchairs involved in sudden stops should be inspected for possible failures in frame and/or components. Frame damage may be represented by but not limited to: visual cracks, dents, metal distortion, bends, or damage to the seating mounting. If the chair no longer drives straight, it could be damaged. **If the wheelchair has been involved in an accident, discontinue use immediately and contact your Sunrise Medical authorized dealer for a thorough inspection.** If the damage is questionable or if there is concern regarding the condition of the chair, Sunrise Medical recommends replacement of the chair.

Wheelchairs involved in collisions should be replaced.

NOTE: the warranty is void on any wheelchair that is involved in a collision.

2.5.1 User and Attendants

DANGER!

1. When transferring the user in or out of the seating system, never use the footplate as a platform.
2. When transferring the user in or out of the seating system, never use the armrest as a means of support.
3. Do not lift this seating system by any parts that are removable. Doing so may result in damage to the seating system or injury to the user.
4. Never try to stop or slow this seating system with the wheel locks (if applicable). Wheel locks are designed to prevent the system from moving when stopped. They are not brakes.
5. Always keep your hands and body parts clear of moving parts to help prevent injuries.

2.5.2 User

DANGER!

1. Every seating system is different.
2. Take the time to learn the feel of this system before you begin riding.
3. Be aware that you must develop your own methods for the safe use of this system that are best suited to your level of function and ability.
4. Have someone help you practice bending, reaching, and transferring until you learn how to do them safely.
5. Never try a new maneuver on your own unless you are sure it is safe.
6. Get to know the areas where you plan to use your system. Look for hazards and learn how to avoid them.
7. Always wear a positioning belt.
8. Do not use a seating system if the joystick does not spring back to the neutral position.
9. Do not use your seating system if the joystick boot is ripped or damaged.
10. Do not try to tip this seating system without an attendant present.
11. Do not allow additional riders; the system may become unstable.

2.5.3 Attendants

DANGER!

Ensure you heed all warnings and follow all instructions in each section of this manual. Warnings that apply to the user also apply to you.

1. Do not stand or sit on any portion of this seating system.
2. You need to work with the user, and the user's doctor or health care provider, to develop safe methods best suited to your abilities and those of the user.
3. To manually push the system you must release the motor brakes.
 - Do not engage or disengage motor brakes **unless** power to the system is **off**.
 - Ensure you have full control over the system when you release the motor brakes. When you do so the system will not have brakes.
 - Ensure the system is on level ground before you release the motor brakes.
4. Check to ensure push handle grips will not rotate or slip off.

2.5.4 Attendant control

DANGER!

Ensure you always have comfortable access to the controls while the chair is moving and ensure that the controller is fixed securely to the chair.

1. Set the speed of the attendant control to a speed that you can comfortably follow.
2. Always turn off the power to the controller when leaving the user in the chair.

2.6 Safety: Accessory Trays

Safety: Vent tray

DANGER!

Using a vent tray will affect the stability and overall weight of your wheelchair.

1. Ensure that the batteries and the ventilator are securely fastened to the tray before use.
2. Familiarize yourself with the increased size of the wheelchair before driving to prevent potential collisions.
3. When activating the recline backrest ensure that the area around the vent tray is clear.
4. Be aware that the vent tray assembly can cause a finger trap hazard when the backrest is reclined.
5. The vent tray is not designed to hold anything other than the vent unit and its batteries. It is not designed to hold an oxygen bottle etc. Use of these items may cause your wheelchair to become unstable.
6. The vent tray must be installed and maintained by a Sunrise Medical authorized dealer.

Safety: Swing away tray

DANGER!

1. The maximum load allowed for the tray is 5.5 lbs (2.5 kg).
2. Do not overload the tray, this could cause the tray to break or could cause the chair to become unstable.
3. Do not leave lit cigarettes or other heat sources on the tray as this could cause the tray to deform and mark.
4. Ensure that all extremities and clothing are clear when positioning the tray for use.

2.7 Safety: Stability

DANGER!

1. Removing the batteries may cause the chair to become unstable causing it to tip backwards.
2. Only remove the batteries while the chair is on the ground.
3. Do not remove the batteries while the chair is on a lift table or on any other elevated surface.

3.0 GENERAL DESCRIPTION

General description

This wheelchair is equipped with the Captain Seat seating system. The Captain Seat seating system provides good support for the head, torso, arms, and legs. Optimal body support ensures maximum independence for the wheelchair user.

The wheelchair must be adjusted by an authorized dealer. Incorrect settings may have negative consequences for the seating posture.

Main Components (Fig.3.1).

1. Flip-back, height adjustable armrest
2. Joystick
3. Captain seat
4. Headrest
5. Single plate foot platform

3.1 Maximum user weight

The overall maximum user weight shall not exceed:
 Captain Seat - 300 lbs (136 kg)

WARNING!

Exceeding the weight capacities could lead to injury and/or permanent damage to the equipment.

NOTE — Exceeding the weight limit will void the warranty.



Fig. 3.1

4.0 WARNINGS FOR COMPONENTS AND OPTIONS

⚠ WARNING!

If you use parts or make changes not authorized by Sunrise Medical it may create a safety hazard and will void the warranty.

4.1 Armrests**⚠ DANGER!**

1. Armrests will not bear the weight of the user.
2. Never lift this system by its armrests. They may come loose or break.
3. When transferring the user in or out of the seating system, never use the armrest as a means of support.

4.2 Cushions**⚠ WARNING!**

1. Standard foam cushions and other body supports are not designed for the relief of pressure.
2. If you suffer from pressure sores, or if you are at risk that they will occur, you may need a special seating system or a device that will help control your posture.
 - Consult your health care provider to find out if you need such a device for your comfort and health.

4.3 Fasteners**⚠ WARNING!**

Many of the screws, bolts, and nuts on this system are special high-strength fasteners. Use of improper fasteners may cause your system to fail.

1. Only use fasteners provided by Sunrise Medical.
2. If fasteners become loose, tighten them immediately.
3. Do not over- or under-tighten fasteners as this can cause damage to your system or its components.
4. Always tighten to specified torque. Specified torque values are listed in Section 8.
5. Do not reuse fasteners.

4.4 Footplate and footrests**⚠ DANGER!**

1. At the lowest point, footrests should be at least 2-in (51mm) off the ground. If set too LOW, they may "hang up" on obstacles you can expect to find in normal use. This may cause the system to stop suddenly and tip forward.
2. To avoid a trip or fall when you transfer:
 - Ensure your feet do not "hang up" or get caught in the space between the footrests.
 - Avoid putting weight on the footrests, as the system may tip forward.
 - Remove or swing the footrests out of the way, if possible.
3. The footrest should always be in the down position when operating the system.
4. Never lift this system by the footrests. Footrests detach and will not bear the weight of this system. Lift this system only by non-detachable parts of the main frame.

4.5 Positioning belts**⚠ DANGER!**

The positioning belt is predominately used to support your posture. It can also be used to limit slipping and/or sliding that you might experience when the system is in motion. The positioning belt is not a transit rated safety belt and should not be used in the place of a seat belt while being transported in a motor vehicle. Improper use of positioning belts may cause severe injury or death. If you use a positioning belt, ensure you follow the recommendations in this section:

1. Ensure the rider does not slide down in the seating system seat. If this occurs, the rider may suffer chest compression or suffocate due to pressure from the belts.
2. The belts must be snug, but must not be so tight that they interfere with breathing. You should be able to slide your open hand, flat, between the belt and the rider.
3. A pelvic wedge or a similar device can help keep the rider from sliding down in the seat. Consult with the rider's doctor or health care provider to find out if the rider needs such a device.
4. Use positioning belts only with a rider who can cooperate. Ensure the rider or attendant can easily remove the belts in case of emergency.
5. NEVER use positioning belts:
 - a. As a patient restraint. A restraint requires a doctor's order.
 - b. On a rider who is comatose or agitated.
 - c. As a motor vehicle restraint. In an accident or sudden stop the rider may be thrown from the system. Seating system positioning belts will not prevent this, and further injury may result from the belts or straps.

If you fail to heed these warnings, damage to your system, a fall, tip-over, or loss of control may occur and cause severe injury to the rider or others.

4.6 Seating systems**⚠ DANGER!**

1. Use of a seating system not approved by Sunrise Medical may affect or interfere with other parts of the system.
2. Never change the seating system unless you consult your Sunrise Medical authorized dealer first.
3. Never raise your seating system to a height of more than 19-in (482mm) (measuring from the front of the seat pan to the floor) with all actuators in their home position.

4.7 Upholstery fabric**⚠ DANGER!**

1. Replace worn or torn fabric of the seat sling and/or seat back as soon as possible. If you fail to do so, the seat may fail and cause you to fall. Worn or torn fabrics may increase the potential for a fire hazard.
2. Fabric will deteriorate with age and use. Look for fraying, thin spots, or stretching of fabric at rivet holes. Replace fabric as required.
3. Be aware that washing may reduce flame retardation qualities of the fabric.

4.8 Wiring and connectors**⚠ WARNING!**

Never pull on cables directly. This can result in wires breaking inside the connector or harness. To remove a plug or connector, always grasp the plug or connector itself.

4.9 Assignable controls**⚠ DANGER!**

It is possible to assign a function to an input control (buttons, jacks) to your seating system. If controls have been assigned to perform a dual or alternate function, ensure you know what each control operates. Please contact your Sunrise Medical authorized dealer if you do not receive this information. Failure to do so may result in damage and/or injury.

4.0 WARNINGS FOR COMPONENTS AND OPTIONS

4.10 Power seating safety

DANGER!

1. Operation

- While driving this seating system in the reclined, elevated, or tilted position use caution.
- Do not attempt to operate any power seating option while positioned on an incline.
- Do not attempt to operate any power seating option while this seating system is in motion.
- Do not attempt to operate the lift or tilt power seating options around children.
- Through programming it is possible to reverse the direction of all powered seating functions. Ensure you know which direction your seat is going to move before operating. Please discuss with your Sunrise Medical authorized dealer which direction the power seating functions have been programmed.

2. Reduced Speed Driving (Creep)

This power system is designed to automatically reduce the maximum driving speed to a creep mode when certain power seating limits are reached. Depending on the configuration of the chair there might be multiple creep speeds. Please discuss the multiple creep speeds with your Sunrise Medical authorized dealer.

Before operating your chair in creep mode, read all warnings and guidelines related to this feature. They will help in understanding how to reduce the risk of a fall or tip-over and how to identify environmental conditions that could affect your safety when driving while the chair is in creep speed.

- When driving indoors or outdoors, in creep mode, it should only be used on flat, level, and hardscape surfaces.
- Driving in creep mode should never be attempted on uneven terrain like: gravel, grass, bumpy surfaces, uneven sidewalks, or hills.
- NEVER raise the seat when the chair is being operated in the proximity of any of the terrain types listed above, or on any uneven surface.

3. Pinch points

Pinch points may occur when operating the powered seating options on this system. Ensure all hands and body parts are clear of all power seating components that may result in pinch points before operating them.

4. Remain clear during power accessory operation

Please stay clear of any powered actuator while the component is in motion. Sunrise Medical power mechanisms move over large ranges of travel. Users should be aware of their surroundings while components are in motion.

5. Maximum user weight

Do not exceed the weight capacity for your specific system/seating system configuration. Doing so could result in premature failure or injury.

6. Latch mode

Use caution while operating any power seating function in latched mode. In latch mode, powered seating will not stop until a reverse command is performed or the end of travel is met. Please consult with your Sunrise Medical authorized dealer to receive training before using latch mode. Failure to do so may result in potential serious injury.

4.11 Power legrest

DANGER!

The power legrest accessory has a maximum user weight capacity of up to 300 lbs (136 kg) depending on your system configuration. Never exceed this capacity while operating the powered actuator.

4.12 Lift / Tilt

DANGER!

Pinch Point

Avoid putting hands, fingers, clothing items, or letting children near the seating system when the Lift / Tilt mechanism is in operation.

Weight Capacity

The powered lift or tilt modular accessory for this system has a maximum user weight of up to 300 lbs (136 kg). Never exceed this capacity while operating the powered actuator.

4.13 Swing away joystick arm

DANGER!

Before adjusting the swing away arm, switch off the controller to avoid accidental displacement of the joystick which would cause unwanted movement of your wheelchair. Be aware that the width of your chair may have increased and you may not be able to go through certain obstacles.

DANGER!

- Only operate the wheelchair at a low and maneuverable speed when the parallel swing-away is in use. (Fig 4.1)
- When transferring to and from the wheelchair, do not use the remote as a means of support.
- Do not hang any items on or over the parallel swing-away remote assembly as this could damage the swing-away mechanism.

Note: hanging items on/near the joystick may cause unwanted movement and potential of serious injury or death!

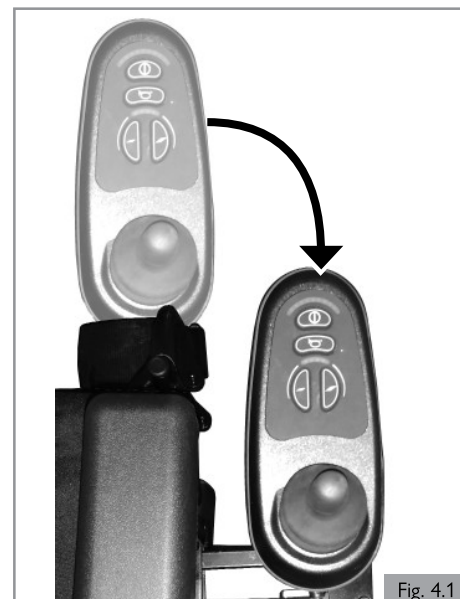

Fig. 4.1

4.14 Transit



Important Transit notes for the chair:

1. If possible and feasible, the rider should transfer to the Original Equipment Manufacturer (OEM) vehicle seat and use the vehicle restraint.
2. If the seating system is used for transport, it must be used in a forward-facing seating position during travel in a motor vehicle.
3. The recommended clear zones for wheelchair seated occupants restrained by both pelvic and upper-torso belt(s) and only by a pelvic belt are shown in the diagrams (Fig 4.2 and 4.3) and described below. Frontal Clear Zones (FCZ) need to be larger when upper torso belt(s) are not used. The Rear Clear Zone of 16-in (40.5 cm) is measured from the rearmost point on an occupant's head. The Front Clear Zone is measured from the front most point of an occupant's head and is 26-in (66 cm) with pelvic and upper-torso belt(s) and 37-in (94 cm) with only a pelvic belt. The frontal clear zone may not be achievable for wheelchair-seated drivers.
4. The estimated seated height (HHT) from the ground or floor to the top of the wheelchair-seated occupant's head ranges from approximately 47-in (119 cm) for a small adult female to about 61-in (155 cm) for a tall adult male (Fig 4.3).
5. The rider must not weight more than 300 lbs (136 kg).
6. Attach WTORS to securement points in accordance with the manufacturer's instructions and SAE J2249.
7. Ensure hip guides are mounted and are locked in place.
8. Only use Wheelchair Tie-down and Occupant Restraint Systems (WTORS) which meet the requirements of SAE J2249 Recommended Practice-Wheelchair Tie-down and Occupant Restraint Systems For Use in Motor Vehicles. Do not use WTORS designed to rely on the wheelchair structure to transfer occupant restraint loads to the vehicle.
9. In order to reduce the potential of injury to vehicle occupants, wheelchair mounted accessories, such as trays and respiratory equipment, should be removed from the seating and wheelchair and secured separately.
10. Postural supports and positioning devices should not be relied on for occupant restraint.
11. Do not alter or substitute wheelchair frame parts, components, or seating.
12. Sudden stops or impacts can structurally damage your system. Chairs involved in such incidents should be replaced.

Important Transit notes for Occupant restraints:

13. Attach occupant restraints in accordance with the manufacturer's instructions and SAE J2249.
14. Both pelvic and upper torso restraint belts must be used to restrain the occupant to reduce the possibility of head and chest impacts with the vehicle components and serious risk of injury to the user and other vehicle occupants (Fig 4.4)
15. The upper torso restraint belt (A) should be mounted to the vehicle (B) pillar. Failure to do so will increase the risk of serious abdominal injuries to the user (Fig 4.4).
16. A head restraint suitable for transportation must be fitted and suitably positioned at all times during transportation.
17. The pelvic restraint belt (C) must be worn low across the front of the pelvis so that the angle of the pelvic belt is within the preferred zone of 30 to 75 degrees to the horizontal (Fig 4.4).
18. A steeper (greater) angle within the preferred zone is desirable closer to, but not exceeding, 75 degrees (Fig 4.6).
19. The upper torso restraint belt (A) must fit over the shoulder and across the chest (Fig 4.4).
20. Restraint belts must be adjusted as tightly as possible consistent with user comfort, and should not constrict breathing (Fig 4.5).

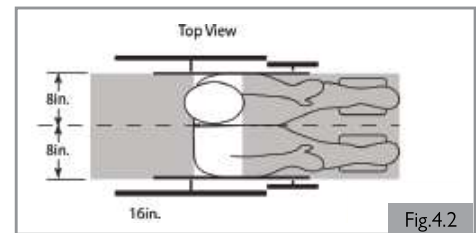

Fig 4.2

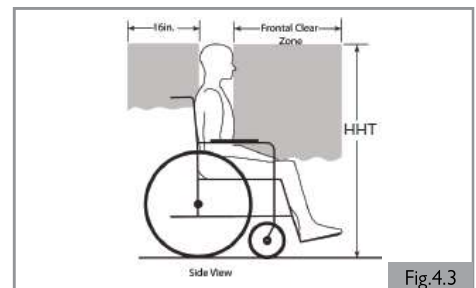

Fig 4.3

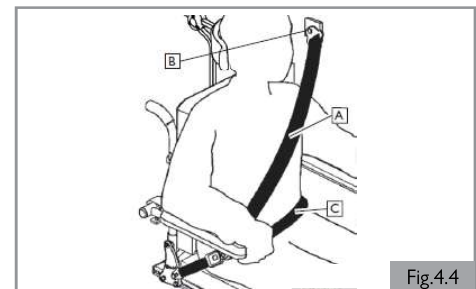

Fig 4.4



Fig 4.5

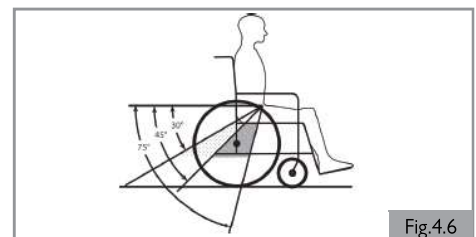

Fig 4.6

5.0 SETTING UP THE SEATING SYSTEM

5.0 Setting up the seating system

The average wheelchair does not exist. This is why Sunrise Medical wheelchairs can be pre-set according to specific needs of the user.

Pre-settings are carried out once, the first time the wheelchair is going to be used. They must be executed by a qualified specialist, unless explicitly stated otherwise.

Tool and calibration marks

A M5 Allen key should be used by a professional for adjusting all the seating system settings.

⚠ NOTE / CAUTION!

There are calibration marks on various parts of the seating system. The ex-factory settings are indicated.

5.1 Pre-set leg rests and footplates (standard Captain Seat)

⚠ WARNING!

- Be aware of your environment to ensure you do not injure your legs when leg rests are extended.
- Always ensure that the leg rests or footplates do not come into contact with the casters before driving the wheelchair.
- Leg rests are not to be used for lifting or carrying the wheelchair under any circumstances.
- As with all moving parts, ensure you do not trap your fingers (Fig. 5.1)

Pre-set footplate height and angle

The power centermount footrest allows angle adjustment from 90° to 180° level to ground and a 7.5-in (190mm) powered length extension.

The left and right footplate can be adjusted by an angle of +/-5.0° and has a mechanical height range adjustment of 3-in to 18-in (76mm to 460mm) measured from the footplate to the seat pan.

Pre-set footplate height

1. Loosen the 2 bolts (A) with a 5.0 mm Allen key. (Fig. 5.2).
2. Slide the footplate receiver up or down in the track to the height desired.
3. Tighten the 2 bolts securely. See section 8 for specified torque values.
4. Repeat for the other side.

Pre-set footplate angle

1. Flip up the footplate so that you can reach the angle setting screw (B). (Fig. 5.3)
2. Use an Allen key to adjust the bolt in or out depending on the angle required.

⚠ WARNING!

1. After adjustment and with the seat in its normal drive position: Ensure there is a gap of at least 2-in (51mm) between the floor and the footplate at all times when maneuvering the footplate up or down.
2. Perform this test with the user sitting in the chair loading the leg rest.
3. Using the chair with the leg rest set too low might result in personal injury or damage to the wheelchair or its surroundings.

Pre-set footplate width

1. Remove bolt (D) with an Allen key. (Fig. 5.4)
2. Move spacer (E) from inside of footrest to the outer side.
3. Reinsert bolt and tighten securely. See section 8 for specified torque values.
4. Repeat for the other side.

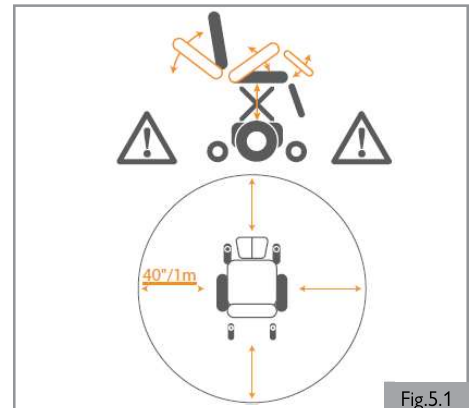

Fig.5.1

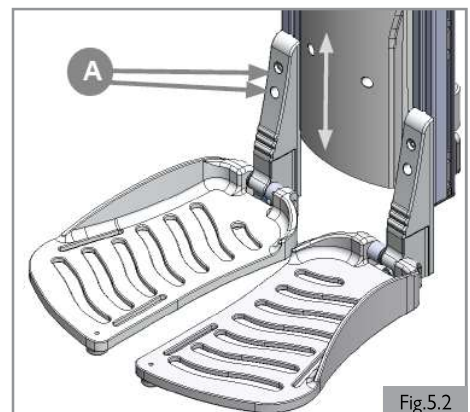

Fig.5.2

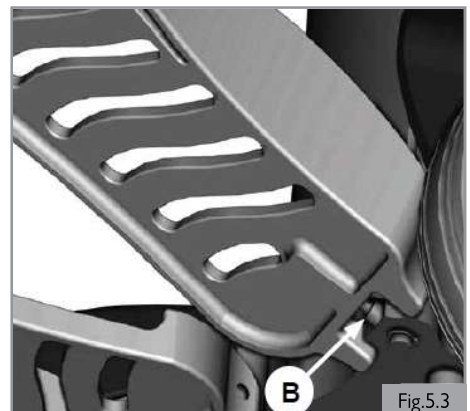

Fig.5.3

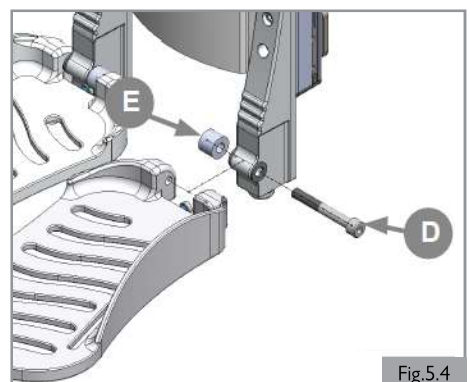

Fig.5.4

5.2 Hanger receiver for swing away legrests (Option)**Hanger receiver width adjustment** (Fig. 5.5 and Fig. 5.6)

1. Remove swing-away legrest. See section 6.7 "Removing a swing-away legrest".
2. Remove screws (A) and washers (B).
3. Slide hanger receiver (C) inward or outward from seat frame to desired location.
4. Reattach screws (A) and washers (B).
5. For power ELR hangers, insert the small end of the wire harness (D) into the top of the hanger receiver. Securely tighten the set screw (E) with a 3mm hex key to secure the harness to the receiver. Torque to 1.5-2.0 Nm [6-8 in-lbs].
6. Reattach swing-away legrest.
7. Repeat steps 1-6 on opposite side of chair.

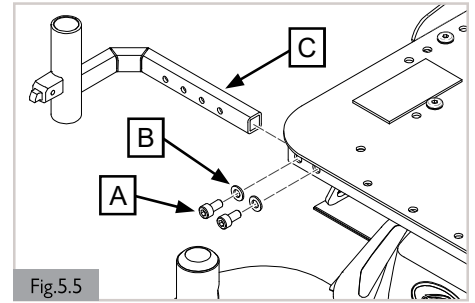

Fig.5.5

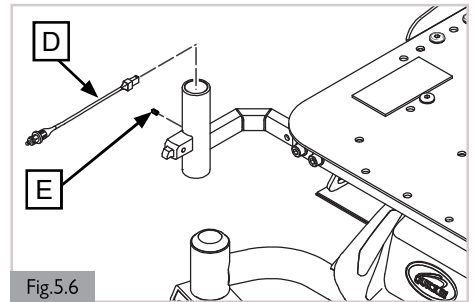

Fig.5.6

5.0 SETTING UP THE SEATING SYSTEM

5.3 Pre-set swing away legrests (Option)

Lower leg length (Fig. 5.7)

1. Loosen (A) by one turn.
2. Adjust (B) to the desired position.
3. Tighten (A).

⚠ NOTE/CAUTION!

Ensure that there is sufficient free space under (B) for the wheelchair to drive over obstacles.

Ankle angle (Fig. 5.8)

1. Loosen (A) a few turns.
2. Adjust (B) to the desired position.
3. Tighten (A).

⚠ DANGER/WARNING!

Risk of trapping fingers! When moving the legrest up or down, do not put your fingers in the adjusting mechanism between the moving parts of the legrest.

⚠ NOTE/CAUTION!

Change the height or knee angle if the footplate touches the caster wheels.

⚠ CAUTION!

Check after setup and/or adjustment of wheelchair: after initial setup by the Sunrise Medical authorized dealer or after making any adjustments to the wheelchair, a check to confirm that no interferences exist must be completed. Interferences can happen (but not limited to) adjustments to the joystick, armrest, specialty control mounts, leg rest, headrest, etc. After an adjustment has been made, the movement of that device may collide or hinder the operation of another component of the wheelchair. A check must be performed prior to operation of the chair to ensure all moving pieces move freely and through the entire range of motion without coming into contact with another part of the wheelchair.

Calf pad height (Fig. 5.9)

1. Loosen (A) a few turns.
2. Adjust (D) to the desired position.
3. Tighten (A).

Calf pad depth (Fig. 5.9)

4. Loosen (B) a few turns.
5. Adjust (D) to the desired position.
6. Tighten (B).

Calf pad width (Fig. 5.9)

7. Loosen (C) on the back of (D) a few turns.
8. Adjust (D) to the desired position.
9. Tighten (C).

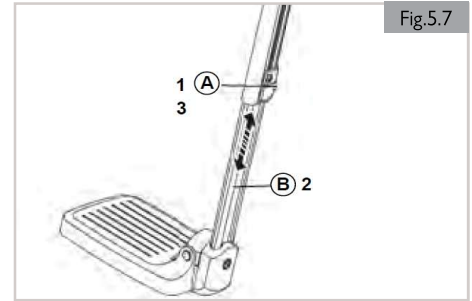

Fig.5.7

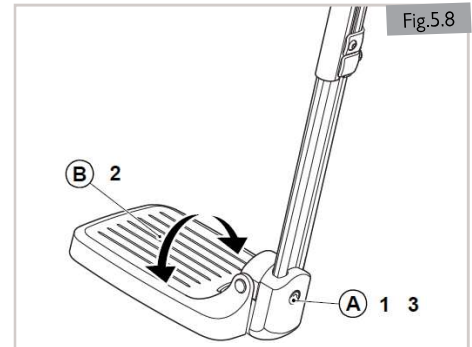

Fig.5.8

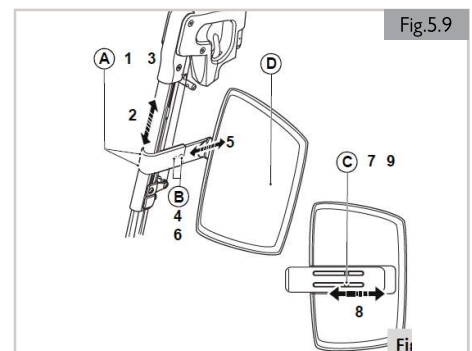

Fig.5.9

5.4 Swing away controller bracket

The joystick can be mounted with a mechanism that allows the joystick to be locked in a forward or retracted position, and can accommodate a mid-line mount so the joystick can be located in the center of the wheelchair.

Swing away (Fig. 5.10)

1. To swing away the joystick, push outward on the inside of the joystick.
2. Push the joystick away from the front of the armrest until it locks into the outside swing away position.
3. To return to forward position, push the back of the joystick forward until it locks into place.
4. To swing away the joystick to the inside, push inward on the outside of the joystick.
5. Push the joystick away from the front of the armrest until it locks into the inside swing away position.
6. To return to forward position, push the back of the joystick forward until it locks into place.

Pre-setting depth of the controller (Fig. 5.11)

1. Loosen knob (A).
2. Slide controller (B) to desired position.
3. Hand tighten knob (A).

There are two ways to pre-set the height of the controller.

Pre-setting height of the controller (1) (Fig. 5.12)

1. Loosen screw (C).
2. Slide controller (B) to desired height.
3. Tighten screw (C). See section 8 for M6 torque.

Pre-setting height of the controller (2) (Fig. 5.13)

1. Loosen screw (D).
2. Slide controller (B) to desired height.
3. Tighten screw (D). See section 8 for M6 torque.

5.5 Check after setup and/or adjustment of wheelchair

After the initial setup by the Sunrise Medical authorized dealer or after making any adjustments to the wheelchair a check to confirm that no interferences exist must be completed.

Interferences can happen (but not limited to) adjustments to the joystick, armrest, specialty control mounts, leg rest, headrest, etc. After an adjustment has been made, the movement of that device may collide or hinder the operation of another component of the wheelchair. A check must be performed prior to operation of the chair to ensure all moving pieces move freely and through the entire range of motion without coming into contact with another part of the wheelchair.

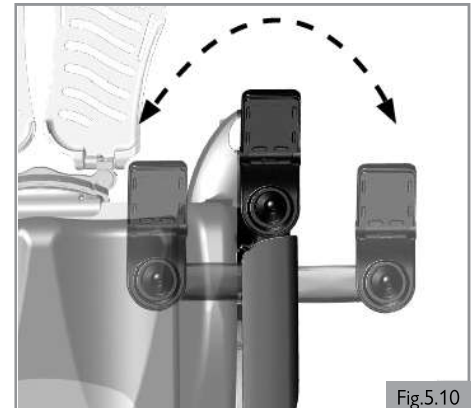

Fig.5.10

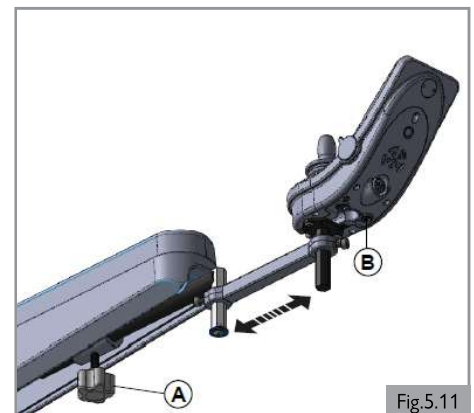

Fig.5.11

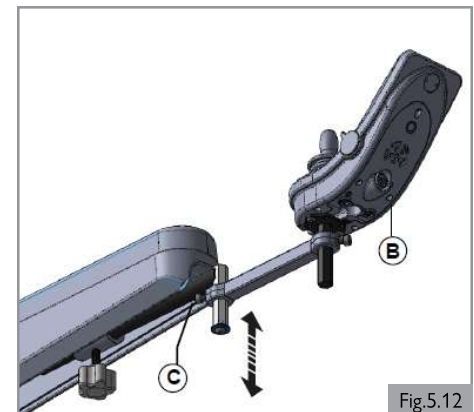

Fig.5.12

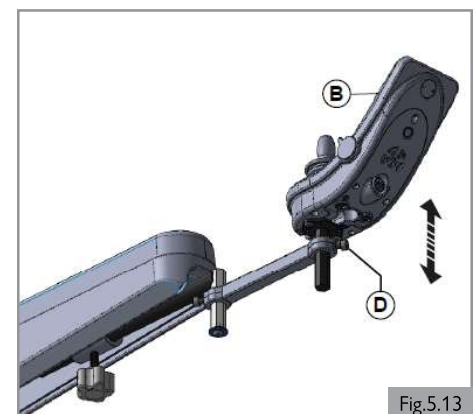

Fig.5.13

5.0 SETTING UP THE SEATING SYSTEM

5.6 Lap belt / seating positioning belt (Fig. 5.14)

WARNING!

1. This product is only to be used to position a single person in a wheelchair.
2. Lap belts are not suitable for transit purposes. Approved occupant restraint systems must be used.
3. Failure to heed these warnings may result in severe injury or death.
4. Ensure that the caregiver or attendant is trained in the correct operation of the belts
5. Untrained caregivers or attendants may lead to delays, if an emergency situation occurs.

Mounting a lap belt / seating positioning belt

1. Attach (A) to the seating frame using provided screws on the left and on the right. (Fig. 5.15)
2. Tighten (B). See section 8 for specified torque values.

Positioning a person with a lap belt

1. Adjust the lap belt to suit, leaving no more than a hand's width gap for comfort and safety. (Fig. 5.16)
2. The hand clearance should be with the lap belt under normal tension and not allow large gaps or loops.
3. Generally, the lap belt should be fixed so that the straps sit at an angle of approximately 45° (Fig. 5.17), and when correctly adjusted should not allow user to slip down in the seat.
4. Place the strap loosely across the seat with the opening end of the buckle facing to the right for a left-handed person and to the left for a right-handed person. Pass the other ends of the strap through the gap between the backrest posts and the backrest.

DANGER/WARNING!

1. Always ensure that the lap belt is correctly secured and adjusted prior to use.
2. Too loose a belt could cause the user to slip down and cause serious injury.
3. Check lap belt and securing components at regular intervals for any signs of fray or damage. Replace if necessary.
4. When servicing, check for correct operation of the release buckle and for any signs of wear on the material or plastic brackets.
5. Regular checks/activities:
 - As with all positioning components, there is a need for corrective adjustments as the person changes their seating position over time.
 - Check the belts regularly for correct fitting, to ensure the safety and comfort of the user.

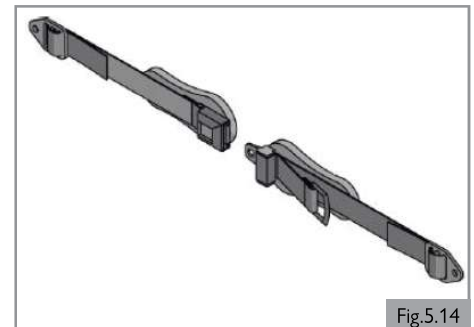

Fig.5.14

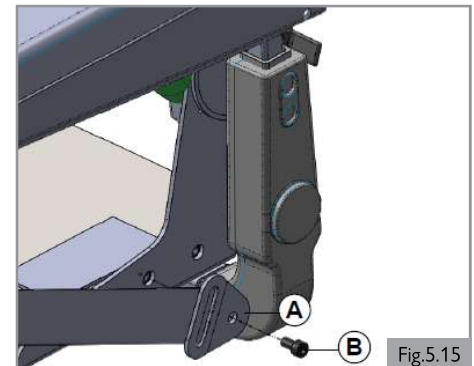

Fig.5.15

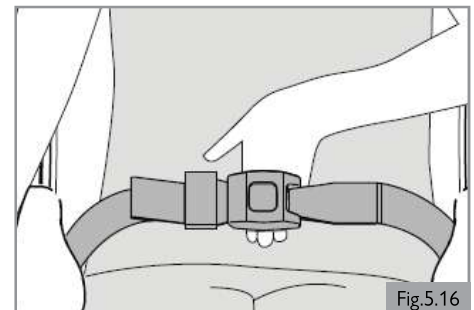

Fig.5.16

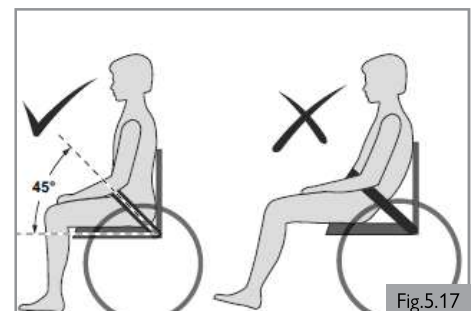

Fig.5.17

6.1 Getting in and out of the wheelchair (Transferring)

Sunrise Medical recommends that you consult your health care provider for assistance in developing your personal front or side transfer technique to best suit your needs and avoid any personal injury.

⚠ DANGER/WARNING!

To prevent a fall:

- Ensure controller is switched off during transfers to avoid unintentional movement. If you fail to do so you may touch the joystick and cause your system to move when you do not expect it.
- Ensure that the free wheel switch has been set to "drive". (ⓘ General manual)
- Rotate the front casters so that they point forward.
- Work with your health care provider to learn all safe methods for transfers.
- Ensure motor brakes are engaged. This keeps the system from moving when you transfer.
- It is dangerous to transfer on your own. It requires good balance and agility. Be aware that there is a point during every transfer when the seating system seat is not below you.
- Learn how to position your body and how to support yourself during a transfer.
- Have someone help you until you are sure you can do a safe transfer on your own.
- Do not stand on the footrest. Putting your full weight on the footrest may lead to wheelchair damage and to hazardous situations, including the wheelchair tipping up.
- Ensure your feet do not "hang up" or get caught in the space between the footrests.

6.2 Preparing for forward transfer

⚠ DANGER/WARNING!

Move your wheelchair as close as possible to the seat you intend to transfer to.

Lower the centermount footplate (if fitted) (ⓘ Controller) (Fig. 6.1)

1. Ensure the area is level and free of obstacles and hazards.
2. Turn the control system ON.
3. Select the powered centermount leg rest.
4. Push the joystick forward until the footplates rest fully on the ground. (Fig. 6.2)
5. Switch the control system OFF before transferring.

⚠ WARNING!

Be aware that when powered, the area around and underneath the footplate needs to be clear of all personal items and bodily extremities to prevent injury or damage to property.

⚠ CAUTION!

Once the leg rest is fully lifted or in its lowest position, do not hold the joystick in its operating position as this could damage the actuator.

Swing-away legrests (Fig 6.3)

1. Fold up the foot supports (A).
2. Swing the calf plates (B) to the side (if applicable).
3. If possible, push (C) to the rear and swing leg rests (D) to the side.

6.3 Preparing for side transfer

⚠ DANGER/WARNING!

1. Move your system as close as you can to the seat you are transferring to. If possible, use a transfer board.
2. Transfer as far back onto the seat surface as you can. This will reduce the risk that you will miss the seat or fall.

⚠ CAUTION!

1. Some versions of the controller will need to be swung aside.
2. Remove the tray before folding back the armrest.
3. Do not lean on the armrest when folded back.

Flip up armrest

1. On the side you wish to transfer from, flip the armrest all the way up until it goes into its mechanical stop. This frees your space for side transfer. (Fig. 6.4)

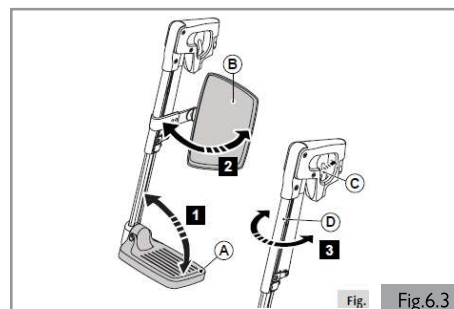
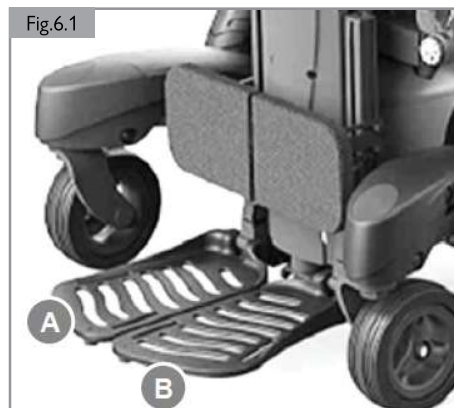

6.0 USING THE SEATING SYSTEM

6.4 Locking pin activation

Configuration for standard use (Driving the chair)

1. Locking pin lever (A) should be disengaged. (Fig. 6.5)
2. Backrest can be reclined or folded as needed.

Transit configuration (Captain Seat used in a vehicle)

3. Locking pin lever (B) should be engaged. (Fig. 6.6)
4. Backrest is now in locked position (99°).



DANGER!

ENSURE YOU ENGAGE LOCKING PIN FOR TRANSIT USE.

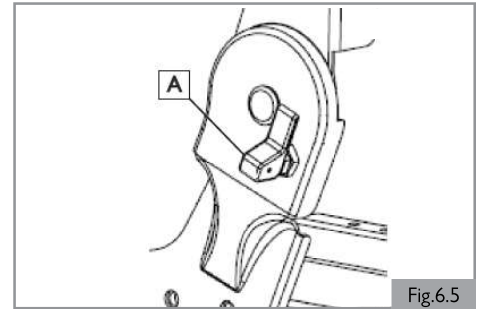

Fig.6.5

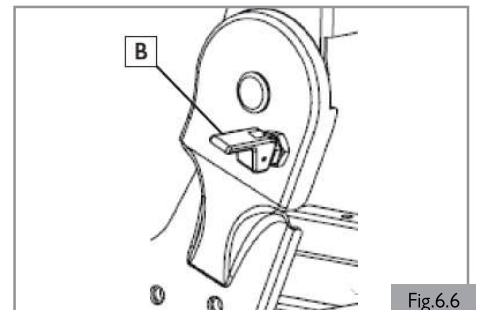

Fig.6.6

6.5 Seat angle adjustment

Adjusting the recline angle (Fig. 6.7)

1. To adjust, pull up on the release lever (C) located on the right side of the backrest.
2. Reposition the backrest forward or backward to the desired position.
3. Release the lever (C) and wiggle the backrest to ensure it locks in place.

Folding the back (unoccupied) (Fig. 6.8)

1. To fold, pull up on the release lever (C) located on the right side of the backrest.
2. The backrest should spring forward into the folded position as shown.
3. Release the lever.
4. To unfold the back, pull up on the release lever (C) and adjust the back to an upright position.

6.6 Seat adjustment

Seat depth adjustments with 1-in increments (Fig. 6.9 and Fig. 6.10)

1. Using a 5mm Hex key, remove the M8 flat head screws (A), 3 on each side.
2. Using a 5mm Hex key, remove the M8 flat head screws (B), 1 on each side.
3. Using a 5mm Hex key, loosen the M8 flat head screws (C), 1 on each side.
4. While holding the backrest on each side, slide it forward or rearward to achieve the desired position.

Note: See section 8 for torque values.



WARNING!

Changing the seat depth can affect the balance of your chair. Test the chair carefully before regular use if a seat depth adjustment has been made.

Seat depth mounting positions

1. Using the seat depth mounting positions table and the hole number callouts, reference the correct hole positions to achieve the desired width and depth.

Seat Depth Mounting Positions			
	16-in wide	18-in wide	20-in wide
14-in deep	—	—	—
15-in deep	2, 4, 6	—	—
16-in deep	3, 5, 7	1, 3, 5	—
17-in deep	4, 6, 8	2, 4, 6	—
18-in deep	5, 7, 9	3, 5, 7	1, 3, 5
19-in deep	—	4, 6, 8	2, 4, 6
20-in deep	—	5, 7, 9	3, 5, 7
21-in deep	—	—	4, 6, 8



Fig.6.7



Fig.6.8

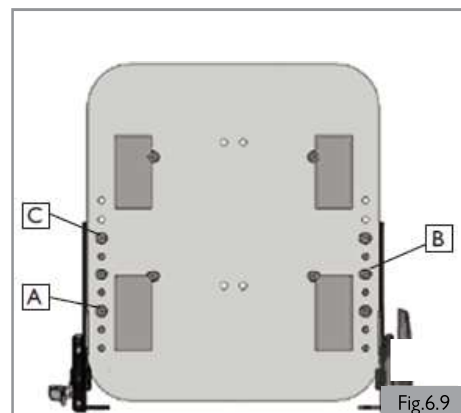

Fig.6.9

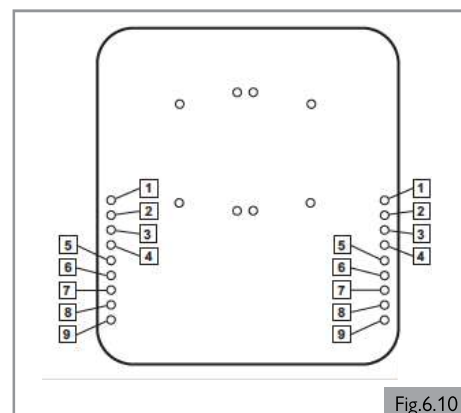

Fig.6.10

6.0 USING THE SEATING SYSTEM

Back height adjustment with 1-in increments

Note: There are 3 positions of adjustment in 1-in increments for the back.

- Position 2 (+2) (D)
 - Position 1 (+1) (E)
 - Position 0 (default) (F)
1. Using a 5mm Hex key, remove the M8 flat head screws, 3 on each side.
 2. Position the backrest at the desired height. The top screw should be mounted as shown. (Fig. 6.11)
 3. Holding the backrest in place, tighten the screws. See section 8 for M8 torque.
 4. Repeat the steps on the other side, and ensure that the left and right sides are positioned at the same height.

Armrest with adjustment

Note: The armrest widths can be changed independently. Remember that this adjustment will increase the overall width of the wheelchair.

1. Locate the 2 armrest fasteners (G) on each side of the armrest receiver bracket. (Fig. 6.12)
2. Loosen the M8 fasteners.
3. Slide the armrests in or out to the desired width.
4. Retighten the fasteners. See section 8 for M8 torque.

Armrest height adjustment

1. Using a 4mm Hex key, loosen the two M5 set screws (H) located on the armrest receiver. (Fig. 6.13)
2. Raise or lower the armrest to the desired height.
3. Tighten the set screws to secure the armrest. See section 8 for M5 torque.

Armrest angle adjustment

1. Lift the armrest straight up so that it is perpendicular to the floor. Raise or lower the armrest to the desired height. (Fig. 6.14)
2. Loosen the jam nut (A).
3. Turn the adjusting screw (B) to raise or lower the front of the armrest.
4. Tighten the jam nut (A) to lock the adjusting screw into place.
5. Ensure that the armrest knob (D) is hand tight when finished. (Fig. 6.15)

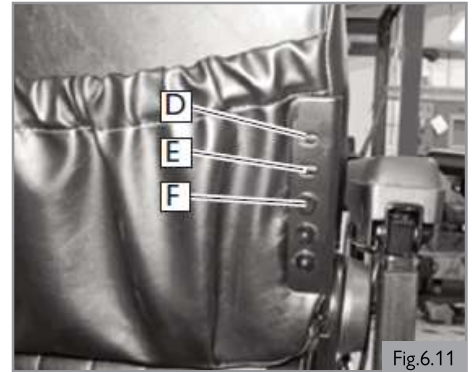

Fig.6.11

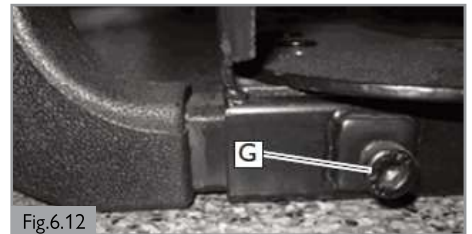

Fig.6.12

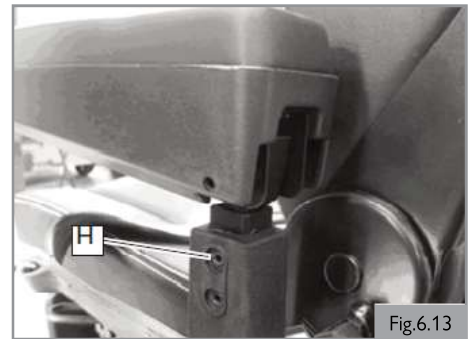

Fig.6.13

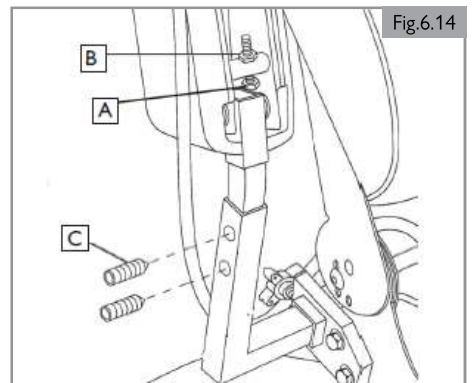

Fig.6.14

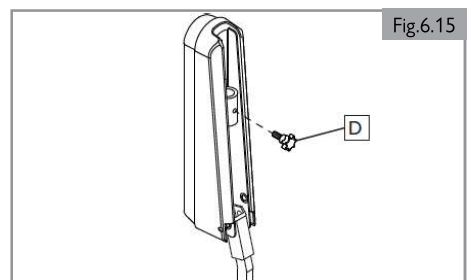

Fig.6.15

6.7 Swing away legrests (Option)**Manually elevating leg rest knee angle (Fig 6.16)**

The angle of the comfort leg rests can be adjusted independently of each other.

1. Push handle (A) forwards.
2. While sitting in the chair, lift your leg.
3. Release the handle when in the desired position.

Removing a swing-away legrest (Fig 6.17)

1. Push the catch (A) to the rear in order to unlock the leg rest.
2. Swing the leg rest outwards.
3. Remove the leg rest (B) from its bracket by lifting.

Note: You should hear an audible click when replacing the leg rest. This indicates that the leg rest has locked into place.

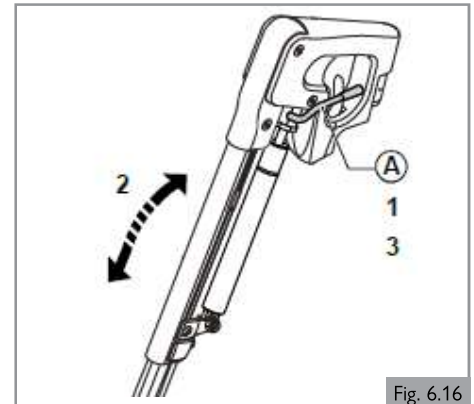

Fig. 6.16

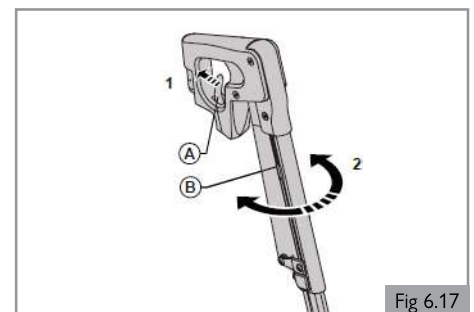

Fig 6.17

7.0 POWERED SEATING OPTIONS

7.1 Powered seating options

The wheelchair can be equipped with the following powered options to adjust your seating position. These options can be operated by the user without the use of tools.

Powered adjustable seating options (Fig 7.1 - Fig 7.3)

How to operate these powered seating options can be found in:

-  **CONTROLLER**
1. Powered tilt function
 2. Powered seat lift
 2. Powered elevating leg rests

DANGER!

1. Use of powered adjustable seating options may influence the stability of the wheelchair.
2. Only use the powered adjustable seating options when the wheelchair is on a flat surface! Do Not attempt to operate any power seating option while positioned on an incline.
3. Please stay clear of any powered actuator while the component is in motion. Sunrise Medical power mechanisms move over large ranges of travel. Users should be aware of their surroundings while components are in motion.
4. While driving this seating system in the elevated or tilted position use caution.
5. Do not attempt to operate any power seating option while this seating system is in motion.
6. Do not attempt to operate the lift or tilt power seating option around children.
7. Through programming it is possible to reverse the direction of all powered seating functions; ensure you know which direction your seat is going to move before operating. Please discuss with your Sunrise Medical authorized dealer which direction the power seating functions have been programmed.
8. Please be aware that the lift/tilt modules present a trap hazard (pinch point). Ensure that during operation the lift/tilt modules are free from all clothing, hands, feet, and other extremities to prevent injury.
9. Do not drive on ramps or slopes with the seating in the elevated position. Before attempting to climb or descend a slope, return the wheelchair to a standard seated drive position, with the backrest upright.
10. This power system is designed to automatically reduce the maximum driving speed to a creep mode when certain power seating limits are reached. Depending on the configuration of the chair there might be multiple creep speeds. Talk to your Sunrise Medical authorized dealer about creep speeds for your chair.

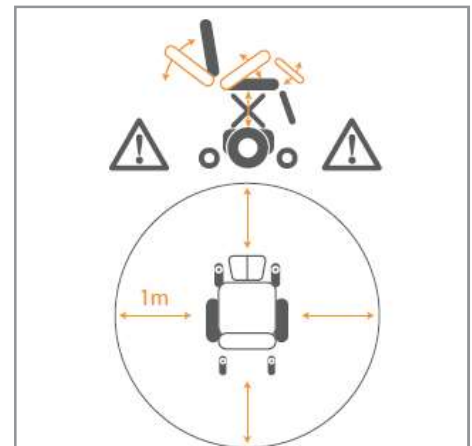

Powered adjustable seating option

Fig. 7.1

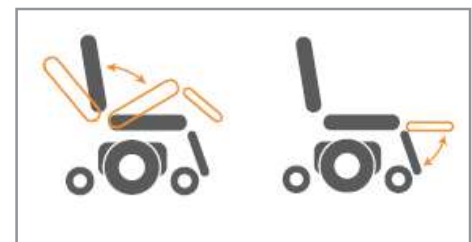

Powered adjustable seating option

Fig. 7.2

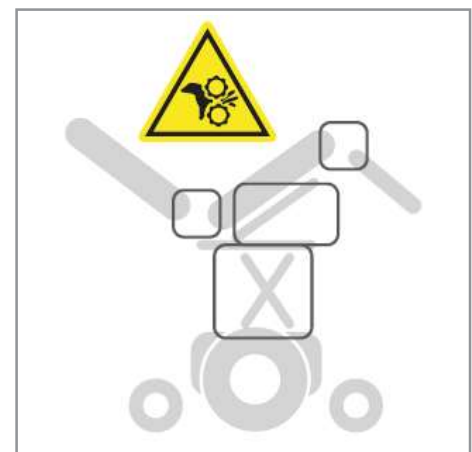

Powered adjustable seating option

Fig. 7.3

The wheelchair's lifespan is dependent on it being well maintained.

For information concerning specific settings, maintenance or repair work, please contact your Sunrise Medical authorized dealer. Always ensure you mention the model and year of manufacture and identification number provided on the serial number label of the wheelchair when contacting your Sunrise Medical authorized dealer.

CAUTION!

The wheelchair should be serviced by your Sunrise Medical authorized dealer once a year or, in the case of intensive use, every six months. For a list of approved authorized dealers in your area please contact Sunrise Medical Service Center.

The contact details of your local Sunrise Medical Service Center can be found on the inside front cover of this booklet.

Website addresses are on the back cover.

8.1 General maintenance

1. All fasteners should be checked quarterly for wear, such as loose bolts or broken components.
2. Loose fasteners should be re-tightened. See section 8 for specified torque values.
3. Check all straps monthly for fraying, ripped seams, or other indications of excessive wear damage. Discontinue use if damage is found.
4. Chest straps should be replaced at the first indication of damage and/or excessive wear.
5. If a broken or loose component is found, discontinue use immediately and contact your Sunrise Medical authorized dealer for replacement.
6. Check all Velcro® fastening straps for correct adhesion when pressed together.
7. Ensure that any contamination, such as fluff, hair, etc is removed from the Velcro® straps. Such contamination may affect adhesion.

Daily checks

Perform the daily check routine before driving as described below.

Checking seating

1. Ensure that all cushions are in place.
2. Ensure that the backrest is correctly fitted and adjusted.
3. Visually inspect the wheelchair to ensure the legrests, armrests, etc. are correctly positioned and attached to the wheelchair and all fasteners are sufficiently tightened. See section 8 for torque values.
4. Ensure that the seat interface knobs are tight and secure.

Checking clothing on potential entrapment

When operating the wheelchair, ensure that your clothing does not hamper the wheelchair (e.g. too long). Before use, always ensure your clothing or accessories do not come into contact with the wheels or other moving and/or rotating parts in which they could become entangled.

Weekly checks

Perform the weekly check routine before driving as described below.

Checking connectors and cables

1. Ensure that all connectors are securely mated.
2. Check the condition of all cables and connectors for damage.

Checking controller

1. Check the thin rubber gaiter or boot around the base of the joystick shaft for damage or splitting. Check visually only; do not handle the gaiter.
2. Ensure that all components of the control system are securely mounted.

Checking controls

1. Switch on the hand control – Do the lights flash? This signifies that there is a fault in the electronic system.
2. Operate all of the electric options, including lights and indicators, (if fitted), to ensure that they work correctly. Refer to ( Controller).
3. Drive the wheelchair in each of the drive profiles to ensure the wheelchair performs as it did before.

General weekly checks

1. Check tires for proper inflation level (if applicable).
2. Check frame and base for foreign objects and/or obstructions.
3. Ensure the knobs that attach the seat frame to the front of the base are not loose.

Quarterly checks

Perform the quarterly check routine before driving as described below.

1. Check all straps for fraying, ripped seams or other indications of excessive wear damage. Discontinue use if damage is found and contact a Sunrise Medical authorized dealer.
2. Check chair for any missing or loose nuts, bolts, and/or fasteners. Contact a Sunrise Medical authorized dealer if found.
3. Check wheelchair for any broken components, unusual wear, or other indicators of excessive wear. Discontinue use if damage is found and contact a Sunrise Medical authorized dealer.

WARNING!

1. If you are in any doubt about the performance requirements of your wheelchair contact your Sunrise Medical authorized dealer.
2. After performing any maintenance or repairs on the wheelchair you must ensure that it is functioning correctly before it is used.
3. A complete inspection, safety check, and service should be made by a Sunrise Medical authorized dealer at least once per year.
4. All fasteners must be replaced like for like using the correct length, tensile strength, and materials.
5. When replacing self-locking nuts, or nuts/studs secured with a thread locking solution, ensure that a suitable thread locking solution is reapplied to the new fastener.
6. Check all Velcro® fastening straps for correct adhesion when pressed together.
7. Ensure that any contamination, such as fluff, hair, etc is removed from the Velcro® straps. Such contamination may affect adhesion.
8. Do not reuse fasteners.

8.2 Cleaning your seating system

The wheelchair should be wiped over once per week with a slightly damp, not wet, cloth and any fluff or dust that has accumulated around the actuators should be blown or dusted away.

CAUTION!

Ensure that you dry all parts of your wheelchair if it becomes wet or damp after cleaning or if it is used in a wet or damp environment.

DANGER!

It is important that should the wheelchair be used by more than one person it is cleaned thoroughly to ensure there is no cross contamination.

8.2.1 Cleaning and inspection of your seating

WARNING!

Tears, dents, wearing, or slackening of upholstery particularly near to metal could result in poor posture or lower levels of comfort and pressure relief.

Cleaning instructions for seating

Wash all parts of the covers with a gentle-wash detergent at 100°F (38°C). You can spin-dry the covers, but do not dry them in a dryer. Remove all parts of the covers independently of each other and wash them separately. Take out the foam inlays prior to washing and close the Velcro® fasteners!

Where upholstery cannot be removed, clean regularly to prevent build up or soiling. Clean with a damp, soapy cloth. Disinfectants may be used in dilution as specified by their manufacturer. Ensure surfaces are rinsed well with clean water and dried thoroughly.

8.0 MAINTENANCE AND CLEANING

8.3 Hygiene measures when being re-used

Prior to the wheelchair being reused, it must be carefully prepared. All surfaces which come into contact with the user must be treated with a disinfectant.

To do this, you must use a suitable disinfectant for rapid alcohol-based disinfection of medical products and medical devices.

Please take into account the manufacturer's instructions for the disinfectant you are using.

CAUTION!

1. Do not use solvents, bleaches, abrasives, synthetic detergents, wax polishes, or aerosols.
2. Disinfectants may be used in dilution as specified by the manufacturer.
3. Ensure surfaces are rinsed with clean water and dried thoroughly.

8.4 General cleaning instructions

CAUTION!

1. You should remove stains on your seat as soon as possible.
2. After a long period of use, you should clean the cover of your seat with a standard commercially available dry foam cleaning agent.
3. You should always clean the whole surface and not just individual spots in order to avoid unattractive edges. The longer you wait the more difficult it will be to remove them.
4. Avoid powerful rubbing with aqueous solutions. This will roughen up cover fabric.
5. Dirt stains (eg. beer, blood, cola, red wine, etc.) are best removed with the dry foam cleaning agents or with a mild action detergent.
6. Please follow the respective instructions of use when treating the covers.
7. The covers should be allowed to dry for at least 48 hours after cleaning with foam cleaning agents.
8. For grease stains (eg. ball point pen, lipstick, chewing gum, etc.) use a proprietary stain remover. Carefully rub the soiled location on the surface only with a clean cloth impregnated with the stain remover.
9. Use only a very small quantity of stain remover.
10. Test a small, inconspicuous area first.
11. The upholstery material must not be saturated, since the stain remover might then change it.
12. Do not use a hose or a pressure washer to clean your chair.

WARNING!

1. Always read the label on any commercial or domestic cleaning substances.
2. Always follow the instructions carefully.

8.5 Cleaning accessories

1. All parts/accessories such as swing away trays should be cleaned with a damp cloth.
2. All lateral supports, headrest, armrests, side guards, calf pads, lap belts, and knee pads should be cleaned with a damp cloth.

8.6 Cleaning controls

Should the controller of your wheelchair become soiled or dirty, it can be wiped with a damp cloth with a dilute disinfectant until clean.

DANGER!

1. This is important should the wheelchair be used by more than one person to ensure there is no cross contamination.
2. Ensure that wafer boards, joysticks (all variants), head arrays, and switches (all variants) are cleaned with a mild disinfectant and a cleaning cloth to avoid any cross contamination possibilities. Following removal from chair regularly wash the sip and puff mouth piece and tube to maintain cleanliness and functionality.
3. Ensure control is switched off before cleaning.

8.7 Storage

To keep the upholstery and other parts of the wheelchair in good condition, store in a dry environment as close to room temperature as possible.

CAUTION!

1. Never store your wheelchair in direct sunlight or in a damp/outdoor environment.
2. Direct sunlight might bleach upholstery/plastic parts and cause metal parts to become hot.

8.8 Maintenance and inspection schedule

To be performed by:

Maintenance and Inspection Schedule	End User / Caregiver			Sunrise Medical Authorized Dealer
	Daily*	Weekly	Quarterly*	Annually
Daily Check routine as described in Section 8.1	<input checked="" type="checkbox"/>			
Weekly Check routine as described in Section 8.1		<input checked="" type="checkbox"/>		
Clean wheelchair upholstery as described in Section 8.2		<input checked="" type="checkbox"/>		
Quarterly Check routine as described in Section 8.1			<input checked="" type="checkbox"/>	
Complete inspection, safety check, and service should be made by a Sunrise Medical authorized dealer				<input checked="" type="checkbox"/>

* Daily = Before each use of the wheelchair. Quarterly = Every three (3) months.

If fasteners are found to be loose a Sunrise Medical authorized dealer should tighten the fastener to the torque setting per size detailed below, unless stated otherwise in all appropriate owner's manuals or instruction sheets (if applicable).

- M8 Fasteners = 13.5-14.9 Nm [120-132 in-lbs]
- M6 Fasteners = 6.8-7.9 Nm [60-70 in-lbs]
- M5 Fasteners = 3.1-3.6 Nm [27-32 in-lbs]
- M4 Fasteners = 0.7-0.9 Nm [6-8 in-lbs]

9.0 TECHNICAL SPECIFICATIONS: APPLICABLE NORMS / STANDARDS



This product complies with the regulations and guidelines for medical aids and carries a CE symbol.

The product meets the requirements and standards below. These are checked by independent institutions.

Standard	Definition / Description	Maximum user weight
EU guideline 93/42 EEC	Applicable as mentioned in Appendix 1	N/A
NEN-EN 12182:2014 Class B	"The requirements from EN12182 as mentioned in NEN-EN 12184: Assistive products for persons with disability - General requirements and test methods"	300 lbs / 136 kg
NEN-EN 12184:2014 Class B	Electrically powered wheelchairs, scooters and their chargers - Requirements and test methods	300 lbs / 136 kg
ISO 7176-8:2014	Requirements and test methods for impact, static and fatigue strengths	300 lbs / 136 kg
ISO 7176-9:2009	Climate tests for electric wheelchairs	N/A
ISO 7176-14:2008	Requirements and test methods for control systems for electric wheelchairs	N/A
ISO 7176-16:2012	Requirements for resistance to ignition of upholstered parts	N/A
ISO 7176-19:2008	Wheelchairs - Part 19: Wheeled mobility devices for use as seats in motor vehicles: The Q-series meet the crash test requirements as described in ISO 7176-19	300 lbs / 136 kg
ISO 7176-4:2008	Wheelchair Energy Consumption Theoretical Range	300 lbs / 136 kg
ANSI/RESNA WC-1:2009	Requirements and test methods for wheelchairs (including scooters)	N/A

THIS GUARANTEE DOES NOT AFFECT YOUR LEGAL RIGHTS IN ANY WAY.

Sunrise Medical* provides a guarantee, as set out in the warranty conditions, for wheelchairs to its customers covering the following.

Warranty conditions

1. **FOR ONE (1) YEAR** - We warrant all Sunrise-made parts and components of this wheelchair including: motors, gearboxes, and electronic components, against defects in materials and workmanship for one year from the date of first consumer purchase.
2. **BATTERIES** - The batteries are covered by a one (1) year warranty provided through the original battery manufacturers.
3. **LIMITATIONS**
 1. We do not warrant:
 - a. Tires and tubes, upholstery, pads, and push-handle grips.
 - b. Damage from neglect, accident, misuse, or from improper installation or repair.
 - c. Products modified without Sunrise Medical's express written consent.
 - d. Damage from exceeding the weight limit.
 2. This warranty is VOID if the original chair serial number tag is removed or altered.
 3. This warranty applies in the USA and Canada only. Check with your Sunrise Medical authorized dealer to find out if international warranties apply.
 4. This warranty is not transferable and only applies to the first consumer purchase of this wheelchair through a Sunrise Medical authorized dealer.
4. **WHAT WE WILL DO** - Our sole liability is to repair or replace covered parts. This is the exclusive remedy for consequential damages.
5. **WHAT AUTHORIZED DEALER MUST DO** -
 1. Obtain from Sunrise Medical, while this warranty is in effect, prior approval for return or repair of covered parts. Contact Customer Service for a Returned Material Authorization (RMA) number and information as to where to return the product. Upon contacting Customer Service please provide Model number, Serial number, description of what is required for service/repair, and any additional information as to reason for service being performed to the wheelchair.

6. NOTICE TO CONSUMER -

1. You must pay the cost of labor to repair, remove, or install parts even if they are covered under warranty.
2. If allowed by law, this warranty is in place of any other warranty (written or oral, express or implied, including a warranty of merchantability, or fitness for a particular purpose).
3. This warranty gives you certain legal rights. You may also have other rights that vary from state to state or province to province.
7. This guarantee is subject to the law of the country in which the product was purchased from Sunrise Medical.

* Denotes the Sunrise Medical facility from which the product was purchased.

ADDITIONAL WARRANTY INFORMATION FOR AUSTRALIA ONLY

1. For goods provided by Sunrise Medical Pty Ltd in Australia, our goods come with a guarantee by Sunrise Medical that cannot be excluded under the Australian Consumer Law.
2. You are entitled to a replacement or refund for a major failure and for compensation for any other reasonably foreseeable loss or damage.
3. You are also entitled to have the goods repaired or replaced if the goods fail to be of acceptable quality and the failure does not amount to a major failure.
4. The benefits to you given by this warranty are in addition to your other rights and remedies under a law in relation to the goods to which the warranty relates.

Record your serial number here for future reference:

(Refer to Base owner's manual for serial number label location)

NOTES



Sunrise Medical S.r.l.
Via Riva, 20 – Montale
29122 Piacenza
Italia
Tel.: +39 0523 573111
www.SunriseMedical.it

Sunrise Medical AG
Erlenauweg 17
CH-3110 Münsingen
Schweiz/Suisse/Svizzera
Tel +41 (0)31 958 3838
www.SunriseMedical.ch

Sunrise Medical AS
Delitoppen 3
1540 Vestby
Norge
Telefon: +47 66 96 38 00
post@sunrisemedical.no
www.SunriseMedical.no

Sunrise Medical AB
Neongatan 5
431 53 Mölndal
Sweden
Tel.: +46 (0)31 748 37 00
post@sunrisemedical.se
www.SunriseMedical.se

MEDICCO s.r.o.
H – Park, Heršpická 1013/11d,
639 00 Brno
Czech Republic
Tel.: (+420) 547 250 955
Fax: (+420) 547 250 956
www.medicco.cz
info@medicco.cz
Bezplatná linka 800 900 809

Sunrise Medical Aps
Mårkærvej 5-9
2630 Taastrup
Denmark
+45 70 22 43 49
info@sunrisemedical.dk
www.SunriseMedical.dk

Sunrise Medical Australia
11 Daniel Street
Wetherill Park NSW 2164
Australia
Ph: +61 2 9678 6600
Email: enquiries@sunrisemedical.com.au
www.SunriseMedical.com.au

Sunrise Medical (US) LLC
North American Headquarters
12002 Volunteer Blvd.
Mount Juliet, TN 37122, USA
(800) 333-4000
(800) 300-7502
www.SunriseMedical.com



© 2025 Sunrise Medical (US) LLC
P/N 247975 Rev. C

Sunrise Medical GmbH
Kahlbachring 2-4
D-69254 Malsch
Deutschland
Tel.: +49 (0) 7253/980-0
Fax: +49 (0) 7253/980-222
www.SunriseMedical.de

Sunrise Medical Ltd.
Thorns Road
Brierley Hill
West Midlands
DY5 2LD
England
Phone: 0845 605 66 88
Fax: 0845 605 66 89
www.SunriseMedical.co.uk

Sunrise Medical S.L.
Polígono Bakiola, 41
48498 Arrankudiaga – Vizcaya
España
Tel.: +34 (0) 902142434
Fax: +34 (0) 946481575
www.SunriseMedical.es

Sunrise Medical Poland
Sp. z o.o.
ul. Elektronowa 6,
94-103 Łódź
Polska
Telefon: + 48 42 275 83 38
Fax: + 48 42 209 35 23
E-mail: pl@sunrisemedical.de
www.Sunrise-Medical.pl

Sunrise Medical B.V.
Defensiedok 20
3433 NE Nieuwegein
The Netherlands
T: +31 (0)30 – 60 82 100
F: +31 (0)30 – 60 55 880
E: info@sunrisemedical.nl
www.SunriseMedical.nl

Sunrise Medical HCM B.V.
Vossenbeemd 104
5705 CL Helmond
The Netherlands
T: +31 (0)492 593 888
E: customerservice@sunrisemedical.nl
www.SunriseMedical.nl
www.SunriseMedical.eu (International)

Sunrise Medical S.A.S
ZAC de la Vrillonnerie
17 Rue Mickaël Faraday
37170 Chambray-Lès-Tours
Tel : + 33 (0) 2 47 55 44 00
Email: info@sunrisemedical.fr
www.SunriseMedical.fr

Sunrise Medical Canada Inc.
1000 Creditstone Rd., Unit #2
Concord, ON, L4K 4P8
Canada
Phone: 1-800-263-3390
Fax: 1-800-561-5834
www.SunriseMedical.ca