



QUICKIE ATTITUDE
NEODRIVES sMMI

Quickie® Attitude

IMPORTANT CONSUMER INFORMATION

NOTICE: This manual contains important instructions that must be passed on to the user of this product. Please do not remove this manual before delivery to the end user.

SUPPLIER: This manual must be given to the user of this product.

USER: Before using this product, read this entire manual and save for future reference.

WARRANTY REGISTRATION: Visit www.SunriseMedical.com to register this product.

Owner's Manual

Quickie® Attitude

INFORMACIÓN IMPORTANTE PARA EL CONSUMIDOR

AVISO: Este manual contiene instrucciones importantes que deben ser entregadas al usuario de este producto. Por favor no retire este manual antes de la entrega al usuario.

DISTRIBUIDOR: Este manual debe ser entregado al usuario de este producto.

USUARIO: Antes de usar este producto, lea este manual en su totalidad y guárdelo para futura referencia.

REGISTRO DE LA GARANTÍA: Visita www.SunriseMedical.com para registrar este producto.

Manual de instrucciones

Quickie® Attitude

INFORMATIONS IMPORTANTES DESTINÉES AU CONSOMMATEUR

AVIS: Ce manuel contient des instructions importantes qui doivent être communiquées à l'utilisateur de ce produit. Prière de ne pas le retirer avant livraison.

FOURNISSEUR: Ce manuel doit être remis à l'utilisateur de ce produit.

UTILISATEUR: Avant d'utiliser ce produit, lisez entièrement ce manuel et conservez-le pour référence ultérieure.

ENREGISTREMENT DE LA GARANTIE: Visitez www.SunriseMedical.com pour enregistrer ce produit.

Manuel d'instructions



SUNRISE MEDICAL LISTENS

Thank you for choosing a Quickie wheelchair. We want to hear your questions or comments about this manual, the safety and reliability of your chair, and the service you receive from your Sunrise supplier. Please feel free to write or call us at the address and telephone number below:

Sunrise Medical (US) LLC
 Customer Service Department
 2842 Business Park Ave
 Fresno, CA 93727
 (800) 333-4000

Be sure to return your warranty card, and let us know if you change your address. This will allow us to keep you up to date with information about safety, new products and options to increase your use and enjoyment of this wheelchair. If you lose your warranty card, call or write and we will gladly send you a new one.

FOR ANSWERS TO YOUR QUESTIONS

Your authorized supplier knows your wheelchair best, and can answer most of your questions about chair safety, use and maintenance. For future reference, fill in the following:

Supplier: _____
 Address: _____

 Telephone: _____
 Serial #: _____ Date/Purchased: _____

ADDITIONAL INFORMATION YOU SHOULD KNOW

No component of this chair was made with Natural Rubber Latex.



Disposal and recycling information:

When this product reaches the end of its life, please take it to an approved collection or recycling point designated by your local or state government. This wheelchair is manufactured using a variety of materials. Your product should not be disposed of as ordinary household waste. You should dispose of your wheelchair properly, according to local laws and regulations. Most materials that are used in the construction of this product are fully recyclable. The separate collection and recycling of your product at the time of disposal will help conserve natural resources and ensure that it is disposed in a manner that protects the environment.

Ensure you are the legal owner of the product prior to arranging for the product disposal in accordance with the above recommendations.

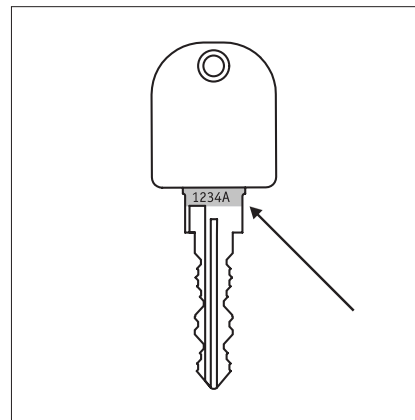

Keys

The battery is supplied with two keys for locking in the battery slide rail. Please record the key identifier number so key can be reordered if required.

NEODRIVES SMMI CONNECT

With neodrives sMMI Connect, you expand the functionality of your Pedelec and get a pleasant riding experience together with the new colour display. This quick start guide introduces you to your new sMMI Connect and how it is used.

Important note: This guide only describes the operation of the sMMI Connect and the associated smartphone app smart Connect. In the smartphone app itself, you can find more information on operation. Also be sure to consult the quick start guide that came with your pedelec for operating information. For more information, visit our website at www.neodrives.de

SCOPE OF DELIVERY

- ✔ neodrives sMMI Connect (display)



Neodrives sMMI Connect

The sMMI is compatible with the bracket docks of the first series as well as with the new bracket docks. The remote control with three buttons (figure 3) is permanently installed/wired on the handlebar dock. The retaining pin on the new bracket dock (figure 2) is used to better secure the sMMI, but you can also safely attach the sMMI to the bracket dock of the old series (figure 4).

ATTACHMENT AND DETACHMENT OF THE SMMI

Attachment (01)

Place the sMMI (figure 5.1) on the dock at an angle of about 30 degrees to the left (figure 5.2). While applying slight pressure, turn the sMMI (figure 5.1) on the dock 30 degrees clockwise so that both components are aligned (figure 5.3). Be sure to avoid putting the sMMI on in the wrong direction.

Detachment (02)

Before detachment, the sMMI must be switched off. Turn the docked sMMI (figure 5.1) by 30 degrees counterclockwise. The electrical connections are detached in the process and the sMMI (figure 5.1) can be removed.



Figure 2: New bracket dock with retaining pin



Figure 3: New ergonomic remote control



Figure 4: Handlebar dock with remote control of the old series

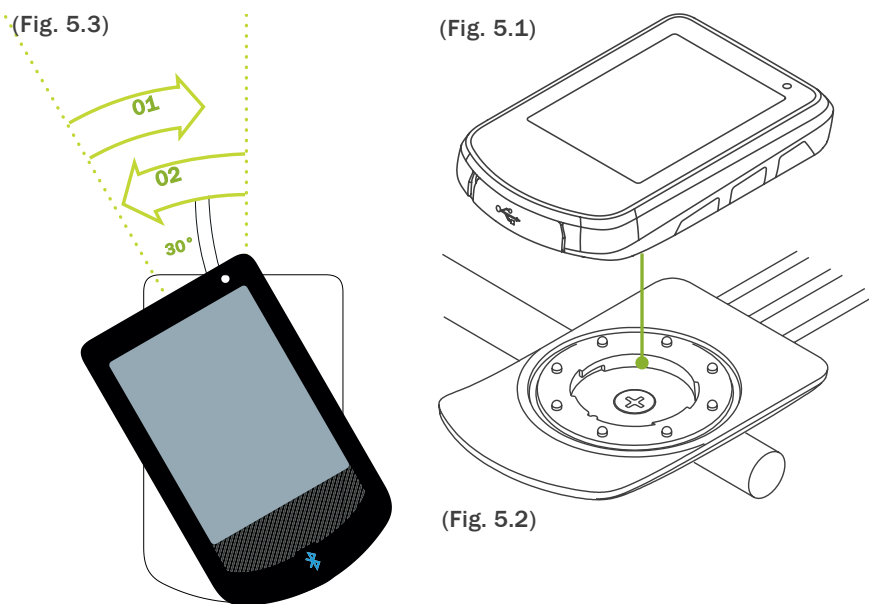

Figure 5: Attaching/detaching the sMMI

SWITCHING ON

Switch on the system by briefly holding down the middle button. If the pedelec has not been in operation for more than 48 hours, first wake up the battery by pressing the button on the battery once.

SWITCHING OFF

To switch off your Pedelec, press the middle button for about two seconds. This takes you to the menu where you can select the "Switch off" function.

AUTOMATIC SHUTDOWN

If your Pedelec is not in use for 10 minutes, the system is automatically switched off.

The standard screen

After switching on, the starting screen appears, followed by the standard screen. The Pedelec is ready for operation.

The following information can be displayed if you briefly press the middle button in the info box:

- Tour km: kilometres travelled on the current tour
- Tour h: travel time on the current tour
- Ø km/h: Average speed on the current tour
- Tot.-km: The total mileage of the motor
- A: Current power consumption
- Eco, Tour oder Boost: selected riding mode. You can find out how to change this riding mode in the next section

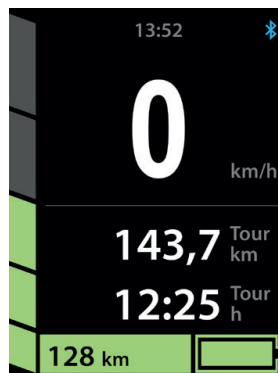

Figure 6: Standard screen

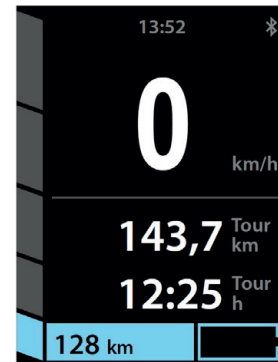

Figure 7: Recuperation level 1

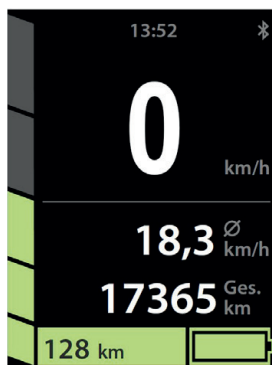

Figure 9: Recuperation active

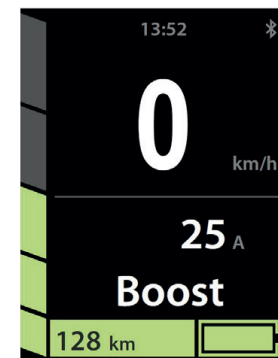

Figure 8: Standard screen 3

CHOOSING THE ASSISTANCE LEVEL / RECUPERATION LEVEL

Use the Up/Down button on the remote control to adjust the levels of assistance or enable recuperation. Please note that recuperation can only be activated with a partially discharged battery (charge status < 90 %), at a battery cell temperature above 0 °C and at speeds of 10 – 28 km/h.

PUSHING AID

Pushing aid can be activated by holding down the **top button** for two seconds.

TOUR RESET

If you press and hold the **bottom button** for at least two seconds, the tour data is reset to zero.



Figure 10: Pushing aid active

MENU TREE OF THE SMMI CONNECT

The menu gives you the option to adjust some settings on your drive system.

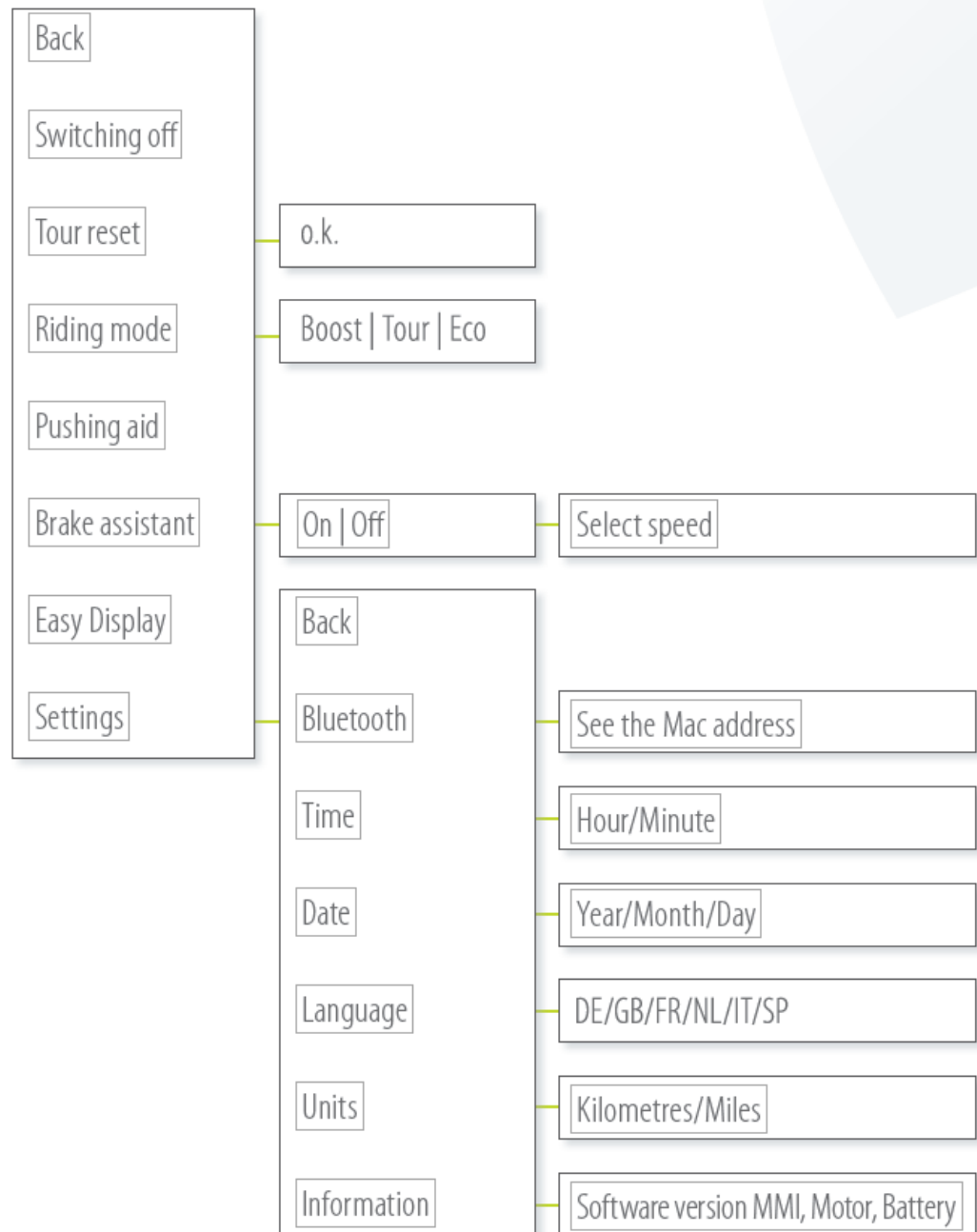

THE INDIVIDUAL MENU ITEMS

SWITCHING OFF

You switch off the system here. After you confirm with the middle button, the manufacturer’s logo appears on the display. Once this disappears, you can remove the sMMI from the dock.

TOUR RESET

As an alternative to the short-cut (pressing and holding the bottom button for at least two seconds), you can delete the tour data of the most recent tour here.

RIDING MODE

Here you have a choice between the three modes Eco, Tour and Boost.

- Eco: moderate responsiveness for greater range
- Tour: good mix of responsiveness and energy-conscious riding
- Boost: sporty responsiveness for brief, fast acceleration

PUSHING AID

As an alternative to the short-cut (pressing and holding the top button for at least two seconds), you can activate the pushing aid here. It is activated immediately when the top button is pressed. Special feature for hand bikes and recumbents: If you activate the pushing aid, you can use the bottom button to push backwards. Please note that pedals/crank then also rotate. With activated pushing aid, the assistance levels can be adjusted as usual from a riding speed of approx. 8 km/h.

BRAKE ASSISTANT

Before a trip, the brake assistant can be activated. It supports you during braking and ensures energy is fed back into the battery (if it is not charged above the threshold of 90 % and the temperature is not below 0 °C). During active recuperation or with active brake assistant, always be ready to brake (using the existing bicycle brakes).

EASY DISPLAY

For a less complex and clearer view of the key features, Easy Display can be activated. You can change the display options by pressing the middle button.



Figure 11: Brake assistant active



Brake assistant active

Figure 12–15 Views of the Easy Display

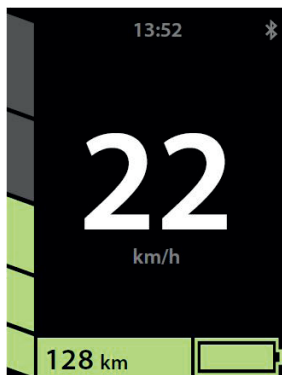

Figure 12

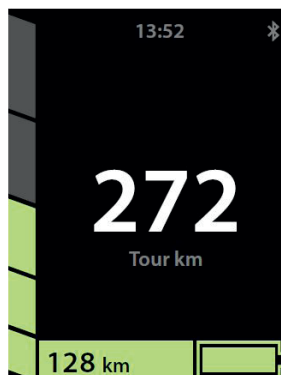

Figure 13

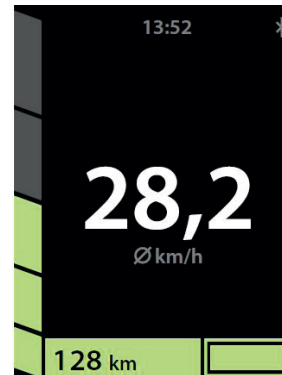

Figure 14

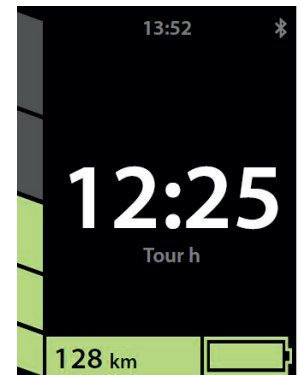









Figure 15

SMMI CONNECT INDICATIONS

NOTE	CAUSE	RECTIFICATION
 SERVICE	Service interval due; either the set kilometres have been reached, or the date. This message disappears from the display after about 20 seconds, and you can ride again as normal	The date can be set or deactivated in the service software
	Battery fully charged	
	Battery almost empty	
	Activated/non-activated brake assistant	The brake assistant is activated and deactivated using the MMI menu
	Bluetooth connection established/terminated	Link/connect the smartphone to the app
	GPS signal is being received / not being received (only with active Bluetooth connection)	Your smartphone is located in a place that is shielded
	Charge level of the smartphone (only with active Bluetooth connection)	
„Light“	Faulty lamp, if the lamp is powered by the system Short circuit in 36V circuit	Replace the lamp Check the cable harness for a broken cable Check the cable harness / battery dock for water ingress Carry out a cross-swap (the cable harness can just be held in place; it does not need to be installed for the test)

CARE INSTRUCTIONS

The removable sMMI is electrically connected to the bracket dock via eight contacts. Each of these eight contacts assumes an important function for the operation of the system, such as the function of the three control buttons or the power supply of the sMMI. It is recommended that the contact surfaces on the sMMI and the contact pins on the bracket dock be cleaned from time to time. Please be sure to use a contact spray that does not contain water.

STORAGE

It is best to store the sMMI at a temperature between 5 °C and 20 °C.
If possible, avoid storage in a damp environment.

TRANSPORT

When transporting the pedelec, always detach the sMMI from the bracket dock and stow it separately in a dry place.

TECHNICAL DATA

- Colour display, 2.4 inches, resolution 240 x 320 pixels
- Dimensions of the sMMI without dock (W x L x H) 53 mm x 85 mm x 14 mm
- Mechanical / electrical contacting rotating bayonet lock
- Lighting LED backlight, 70 – 350 cd/m²
- USB port for connecting the sMMI with the diagnostic software (to be carried out only by specialist dealers)
- Weight of the sMMI: approx. 60 g

SMARTPHONE APP “SMART CONNECT”

In sMMI Connect there is a Bluetooth connection that allows you to connect your smartphone (Android or iOS)* with the sMMI. This makes it possible for you to expand the functionality of the sMMI to include features like tour tracking or navigation.

INSTALLING THE APP ON YOUR SMARTPHONE

You can find the app in the Google Play Store or the Apple App Store by searching for “neodrives smart Connect”. Download the app for installation. To do this, follow the instructions on your smartphone.



Start the app

Launch the app by tapping the app icon.



Icon for launching the app

You may be prompted to select a language and to save your user data (optional). After a short loading time, the view shown here (figure 16) appears.



Figure 16: App screen “Ride”

App available for Android; also available for iOS starting in the summer of 2016

CONNECTING WITH THE SMMI

On the top right, tap . If the Bluetooth is not activated on your phone, you will be prompted to activate it. Confirm the Bluetooth authorisation request with “Yes”. Switch on the sMMI. Now your smartphone searches for a suitable device and finds your sMMI. Tap the “Connect” button to establish the connection. Once the connection is successfully established, on the smartphone you will see the message “Connection successful” and on your sMMI the previously grey Bluetooth icon lights up on the top right in blue.

Special case: Several sMMIs switched on near you

To connect to the desired sMMI, please refer to the sMMI menu to search for the Bluetooth name of your sMMI, which consists of a long sequence of letters and numbers.

The following features require an active Bluetooth connection. You can recognise a terminated Bluetooth connection by a Bluetooth icon that is red or grey instead of blue.



Figure 18: Bluetooth connection active/terminated/inactive

OPERATING THE APP

By tapping  on the top left – alternatively you can swipe towards the centre from the left edge with your finger – you will get an overview of the individual menus of the app, which can be selected by tapping.

 on the top right takes you to the general settings. These may be available only after an in-app purchase.

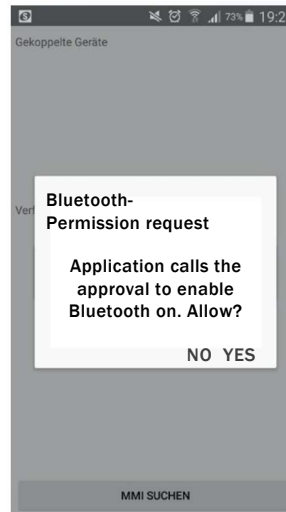

Figure 17: Bluetooth authorization request

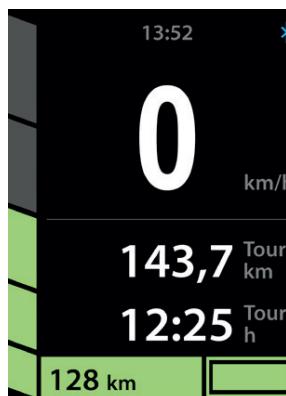

Figure 19: Connected with the smartphone via Bluetooth

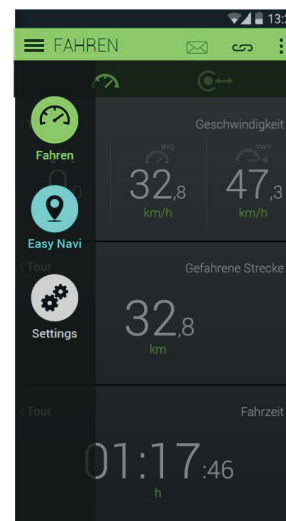

Figure 20: Expanded menu

“RIDE” MENU

You have several options:

1. Use your smartphone as a second display. If you secure it to the handlebars, you can display the speed, daily kilometres travelled, etc.
2. Tour tracking: You can log your trip and later analyse it easily. To do this you tap “Start tour” at the beginning and “End tour” at the end.
Note: Activate the GPS receiver of your smartphone to also record your tour geographically. You can then view the tour on a map afterwards
3. Tour history: All tours that you take are automatically saved to the tour history. This allows you to analyze or delete old tours.



Fig. 21: Start Tour



Fig. 22: End Tour

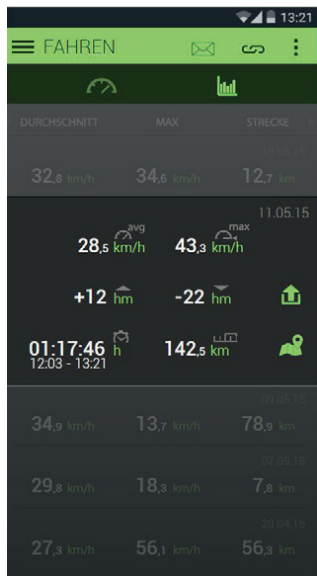

Figure 24: Tour history



Figure 23: “Ride” view: You start recording the tour by tapping the Play icon

“EASY NAVI” MENU

The ideal complement for touring cyclists and urban explorers is the user-friendly navigation function “Easy Navi”. It can be activated via in-app purchase and provides the user with global maps even when they are off-line. This is particularly advantageous because the smartphone has the maps even without access to the Internet and the data does not need to constantly load.*

* An Internet connection is momentarily required for route planning.

THE FEATURES

- * Display of arrow or map navigation* on the sMMI display
- * Routing by entry of an address or import of GPX data
- * Depending on the smartphone model, there may be differences in the presentation options and presentation speed of the map navigation.

To use Easy Navi, follow the instructions for in-app purchase. Once the function is enabled, you have the option of downloading maps.

Start-destination navigation

Please enter your desired starting point and your destination. Starting point: In most cases you can select your current location by tapping the adjacent icon.



Figure 25: My position

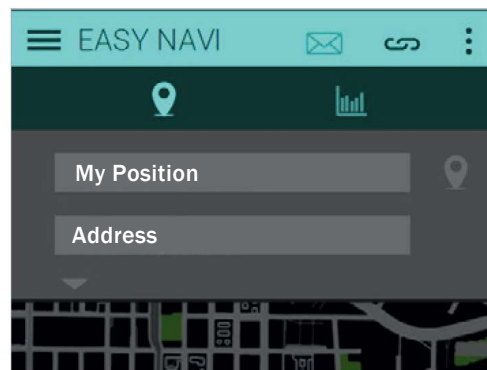

Figure 26: Address entry

If GPS is not activated on your phone, you will be prompted to activate it. Confirm the GPS authorisation request. After a short wait, a GPS signal is detected. If the GPS geolocation is not working, you should eliminate any factors that may be interfering with it. For the geolocation, remove your phone from the case so that it does not negatively affect GPS performance. Also, you should not be in a building, as thick walls can strongly affect the GPS signal, and your phone will not be able to establish a GPS connection. Also note that in some areas this may take up to five minutes. Please be patient.

Note: You can plan your tour even without GPS reception (by entering a place as a starting point). The GPS connection must be active when you start the navigation at the latest.

Destination: Please enter your destination in this order: street, house number, place, such as Friedrichstrasse 19, Berlin. Other input formats are also recognised to some extent.

If you tap the “Plan route” button, you can see the calculated route. Start the navigation by pressing the Play button on the bottom right.

Double-click the middle button of the remote control to copy the routing information to the sMMI.

The smartphone can be stowed in your pocket.

Arrow navigation: Display of directional arrows and turning instructions.

Map navigation: Display of a map section. By double-clicking the top button of the remote control, you zoom in, and if you double-click the bottom button, you zoom out.*

* Depending on the smartphone model, there may be differences in the presentation options and presentation speed of the map navigation.

Note regarding the smartphone’s battery life: Transfer of the map and routing information from the smartphone to the sMMI increases the power consumption of the smartphone. We recommend extension of the runtime using a power bank (spare battery). You can of course use the navigation function when touring with all other bicycles.



Figure 27: Start navigation

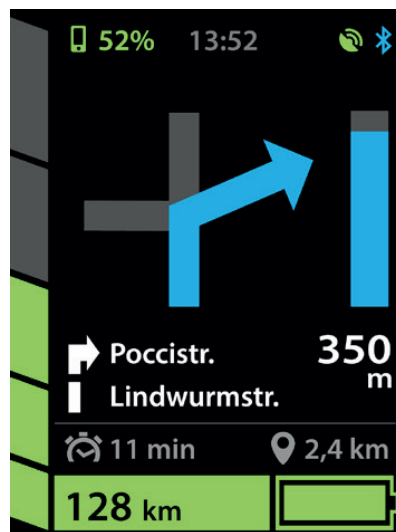

Figure 28: Navigation view 1 on the sMMI Connect

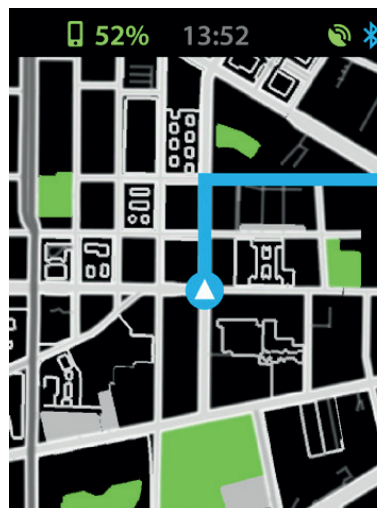

Figure 29: Navigation view 2 on the sMMI Connect

Figure 30: Three zoom levels, level 2 active



WHAT TO DO IF ...

the navigation transfer to the sMMI does not start/stops working?

Please make sure that:

- Your smartphone battery is sufficiently charged
- Your smartphone has GPS reception – you can recognise existing GPS reception by the green GPS icon at the top of the sMMI
- The Bluetooth connection between sMMI and smartphone is established – you can recognise an active connection by the blue Bluetooth icon in the top right corner of the sMMI

For more information, see the Smartphone app under the menu item “Settings”/image, “FAQ”, and on our website www.neodrives.de



GPS symbol



Bluetooth symbol

For more information on the SMMI see Neodrive User Manual at www.neodrives.com. Downloads/User manual sMMI and Motor English.



Sunrise Medical • 2842 Business Park Ave. • Fresno, CA 93727 • USA
In Canada (800) 263-3390



Customer Service: 800.333.4000
www.SunriseMedical.com

©2016 Sunrise Medical (US) LLC
9.16 MK-100383 Rev A